



Crane Rental • Heavy Machinery Moving • Project Management

sales@reliablecraneservice.com • 702-525-0840 or 702-400-2516



PEINER SK 575

Hammerhead Tower Crane
35,200-70,500 lbs. (16-32 t)
Lifting Capacity

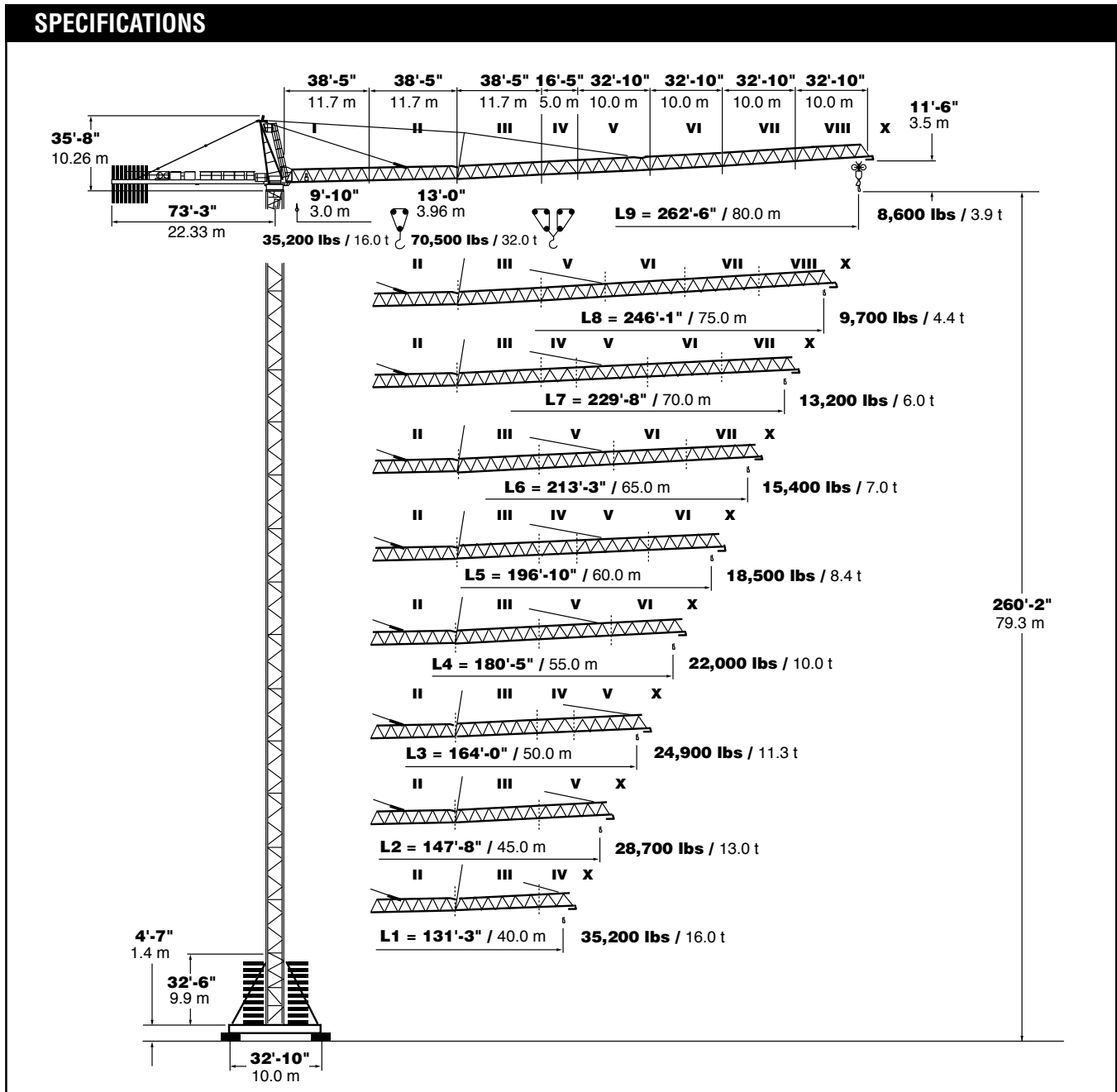

FOR REFERENCE USE ONLY!
Please consult Reliable Crane Service for more information.

702-400-2516 or 702-525-0840
sales@reliablecraneservice.com

www.reliablecraneservice.com



PEINER SK 575

Combinations of tower section, tower heights, base ballast

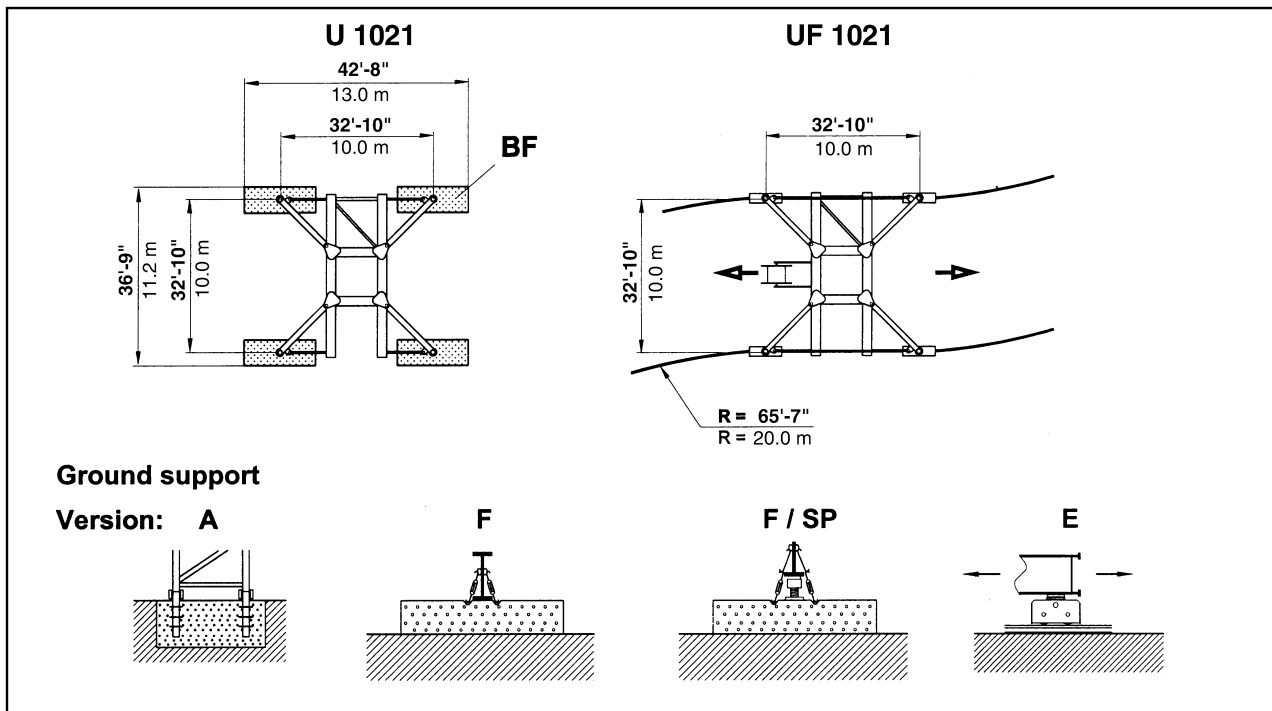
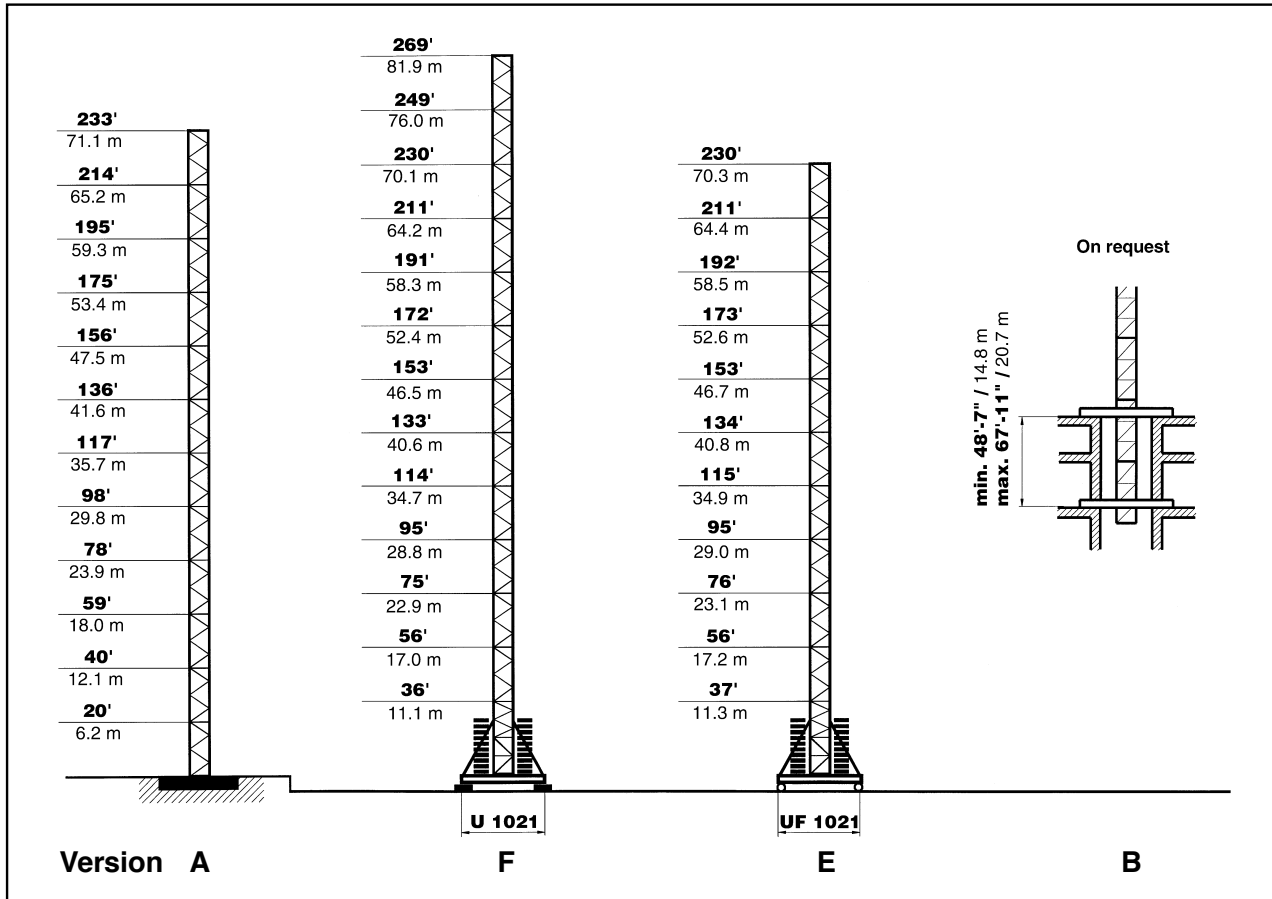



PEINER SK 575 Dimensions and transport weights

See operating manual for mounting weights

	Designation		Dimensions (ft / m)			Weight lbs / t		
			l	b	h			
1	Jib		39'-0" 11.89	6'-6" 1.97	6'-11" 2.12	7490 3.40		
	Section II		40'-6" 12.34	6'-6" 1.97	7'-3" 2.21	8860 4.02		
	Section III		38'-10" 11.84	6'-6" 1.97	7'-7" 2.30	5420 2.46		
	Section IV		18'-8" 5.69	6'-6" 1.97	6'-10" 2.09	5360 2.43		
	Section V		35'-0" 10.68	6'-6" 1.97	6'-11" 2.11	5200 2.36		
	Section VI		35'-5" 10.79	6'-6" 1.97	6'-4" 1.93	4280 1.94		
	Section VII		33'-6" 10.20	6'-6" 1.97	6'-3" 1.90	2760 1.25		
	Section VIII		33'-5" 10.19	6'-6" 1.97	6'-2" 1.88	1700 0.77		
	Jib Tip		6'-8" 2.02	4'-6" 1.37	2'-11" .88	660 0.30		
	2		Tower Top cpl.		27'-1" 8.26	6'-5" 1.96	6'-6" 3.1	9590 4.35
	3		Turntable cpl.		11'-9" 3.58	7'-1" 2.17	7'-5" 2.27	24,100 10.93
4	Cab		5'-5" 1.65	3'-7" 1.10	7'-2" 2.18	1040 0.47		
	Support, railing, electrical panel		11'-8" 3.55	6'-7" 2.00	6'-5" 1.95	2050 0.93		
5	Counterjib	G 2	38'-10" 11.85	7'-5" 2.25	5'-11" 1.80	7500 3.40		
		G 1	31'-1" 9.48	6'-8" 2.03	5'-8" 1.72	6030 2.74		
6	Counterjib ballast	BG	5'-11" 1.81	0'-8" 0.19	10'-4" 3.14	3200 1.45		
			5'-11" 1.81	0'-8" 0.19	15'-4" 4.68	6800 3.10		
7	Tower section	TS 213.1	19'-6" 5.95	7'-10" 2.39	7'-10" 2.38	9790 4.44		
		TSV 213	39'-4" 12.00	10'-4" 3.15	10'-4" 3.15	31,090 14.10		
8	Rail mounted undercarriage with electrical panel		44'-0" 13.40	9'-6" 2.90	3'-9" 1.15	38,440 17.10		
			8'-2" 2.50	2'-8" 0.82	2'-11" 0.89			
9	Central ballast block	BZ	13'-5" 4.50	6'-1" 2.05	1'-2" 0.40	14,550 6.60		
10	Foundation block	BF	9'-0" 3.00	3'-7" 1.20	2'-6" 0.75	14,550 6.60		
11	Accessories							

For more information, product demonstration, or details on lease and rental plans, please contact your local Terex Towers Distributor.

We reserve the right to amend these specifications at any time without notice. The only warranty applicable is our standard written warranty applicable to the particular product and sale. We make no other warranty, expressed or implied.



202 Raleigh Street
Wilmington, NC 28412 USA
(910) 395-8500 • FAX: (910) 395-8547
E-mail: wilmington@terexlifting.com

www.terexlift.com

FOR REFERENCE USE ONLY!

Please consult Reliable Crane Service for more information.

702-400-2516 or 702-525-0840
sales@reliablecraneservice.com