



# Technical Data

## Specifications & Capacities

# HTC 8675

**Telescopic Boom Truck Crane**  
75 ton (68.0 metric ton)

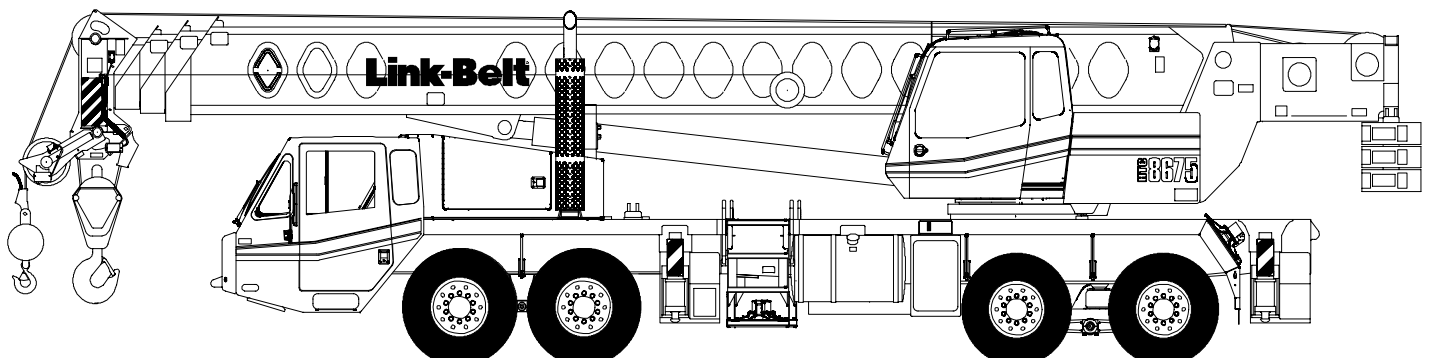

**CAUTION:** This material is supplied for reference use only. Operator must refer to in-cab Crane Rating Manual and Operator's Manual to determine allowable crane lifting capacities and assembly and operating procedures.



5480 (supersedes 5456)–0706–F2



# Table Of Contents

<b>Boom, Attachments, and Upper Structure</b> .....	<b>1</b>
Boom .....	1
Boom Head .....	1
Boom Elevation .....	1
Auxiliary Lifting Sheave – Optional .....	1
Hook Blocks and Balls – Optional .....	1
Fly – Optional .....	1
Upper Operator’s Cab and Controls .....	1
Swing .....	2
Electrical .....	2
Load Hoist System .....	2
Load Hoist Performance .....	2
2M Main and Optional Auxiliary Winches .....	3
Hydraulic System .....	3
Counterweight .....	3
<b>Carrier</b> .....	<b>4</b>
General .....	4
Outriggers .....	4
Steering and Axles .....	4
Suspension .....	4
Tires and Wheels .....	4
Brakes .....	4
Electrical .....	4
Engine .....	4
Transmission .....	4
Carrier Speeds and Gradeability .....	5
Fuel Tank .....	5
Hydraulic System .....	5
Pump Drive .....	5
Lower Cab and Controls .....	5
Additional Equipment .....	6
<b>Axle Loads</b> .....	<b>7</b>
<b>Axle Loads with 2–Axle Boom Dolly</b> .....	<b>8</b>
<b>General Dimensions</b> .....	<b>9</b>
<b>Working Range Diagram</b> .....	<b>10</b>
<b>Boom Extend Modes</b> .....	<b>11</b>
<b>Main Boom Lift Capacity Charts – Standard</b> .....	<b>12</b>
12,000 lb Counterweight – Fully Extended Outriggers – 360° Rotation .....	12
12,000 lb Counterweight – On Tires – Stationary – Boom Centered Over Rear .....	13
12,000 lb Counterweight – On Tires – Pick & Carry (1 mph) – Boom Centered Over Rear .....	13



5480 (supersedes 5456) – 0706 – F2

<b>Main Boom Lift Capacity Charts – Optional</b> .....	<b>14</b>
16,000 lb Counterweight – Fully Extended Outriggers – 360° Rotation .....	14
16,000 lb Counterweight – On Tires – Stationary – Boom Centered Over Rear .....	15
16,000 lb Counterweight – On Tires – Pick & Carry (1 mph) – Boom Centered Over Rear .....	15
<b>Fly Attachment Lift Capacity Charts – Optional</b> .....	<b>16</b>
12,000 lb Counterweight – Fully Extended Outriggers – 360° Rotation .....	16
115 ft Main Boom Length – 2° Fly Offset .....	16
115 ft Main Boom Length – 20° Fly Offset .....	16
115 ft Main Boom Length – 40° Fly Offset .....	16
16,000 lb Counterweight – Fully Extended Outriggers – 360° Rotation .....	17
115 ft Main Boom Length – 2° Fly Offset .....	17
115 ft Main Boom Length – 20° Fly Offset .....	17
115 ft Main Boom Length – 40° Fly Offset .....	17
<b>Main Boom Lift Capacity Charts – Optional (Metric)</b> .....	<b>18</b>
5 445kg Counterweight – Fully Extended Outriggers – 360° Rotation .....	18
5 445kg Counterweight – On Tires – Stationary – Boom Centered Over Rear .....	19
5 445kg Counterweight – On Tires – Pick & Carry (1.6km/h) – Boom Centered Over Rear .....	19
<b>Main Boom Lift Capacity Charts – Optional (Metric)</b> .....	<b>20</b>
7 260kg Counterweight – Fully Extended Outriggers – 360° Rotation .....	20
7 260kg Counterweight – On Tires – Stationary – Boom Centered Over Rear .....	21
7 260kg Counterweight – On Tires – Pick & Carry (1.6km/h) – Boom Centered Over Rear .....	21
<b>Fly Attachment Lift Capacity Charts – Optional (Metric)</b> .....	<b>22</b>
5 445kg Counterweight – Fully Extended Outriggers – 360° Rotation .....	22
35.05m Main Boom Length – 2° Fly Offset .....	22
35.05m Main Boom Length – 20° Fly Offset .....	22
35.05m Main Boom Length – 40° Fly Offset .....	22
7 260kg Counterweight – Fully Extended Outriggers – 360° Rotation .....	23
35.05m Main Boom Length – 2° Fly Offset .....	23
35.05m Main Boom Length – 20° Fly Offset .....	23
35.05m Main Boom Length – 40° Fly Offset .....	23



## Boom, Attachments, and Upper Structure

### ■ Boom

**Design** – Four section, box type construction of high tensile steel consisting of one base section and three telescoping sections. The vertical side plates have diamond shaped steel impressions for superior strength to weight ration. The first telescoping section extends independently by means of one double-acting, single stage hydraulic cylinder with integrated holding valves. The second and third telescoping sections extend proportionally by means of one double-acting, single stage cylinder with integrated holding valves and cables.

### Boom

- 38–115 ft (11.6–35.1m) four section full power boom
- Two mode boom extension: A-max mode provides superior capacities by extending the first telescoping section to 63.6 ft (19.4m). Standard mode synchronizes all the telescoping sections proportionally to 115 ft (35.1m). Controlled from the operator's cab.
- Mechanical boom angle indicator
- Maximum tip height for A-max mode is 72 ft (21.9m) and standard mode is 122 ft (37.2m).
- Provisions for boom dolly connection

### Boom Head

- Five 16.5 in (41.9cm) root diameter nylon sheaves to handle up to ten parts of line
- Easily removable wire rope guards
- Rope dead end lugs on each side of the boom head
- Boom head is designed for quick-reeve of the hook block

### Boom Elevation

- One double acting hydraulic cylinder with integral holding valve
- Boom elevation:  $-3^{\circ}$  to  $78^{\circ}$

### Auxiliary Lifting Sheave – Optional

- Single 16.5 in (41.9m) root diameter nylon sheave
- Easily removable wire rope guards
- Does not affect erection of the fly or use of the main head sheaves

### Hook Blocks and Balls – Optional

- 40 ton (36.3mt) 4 sheave quick-reeve hook block with safety latch
- 60 ton (54.4mt) 4 sheave quick-reeve hook block with safety latch
- 75 ton (68.0mt) 5 sheave quick-reeve hook block with safety latch
- 8.5 ton (7.7mt) swivel and non-swivel hook balls with safety latch

### Fly – Optional

- 36 ft 6 in (11.1m) one piece lattice fly, stowable, offsettable to  $2^{\circ}$ ,  $20^{\circ}$ , and  $40^{\circ}$ . Maximum tip height is 157 ft (47.9m).

- 36 ft 6 in–61 ft (11.1–18.6m) two piece bi-fold lattice fly, stowable, offsettable to  $2^{\circ}$ ,  $20^{\circ}$ , and  $40^{\circ}$ . Maximum tip height is 182 ft (55.5m).

### ■ Upper Operator's Cab and Controls

**Environmental Cab** – Fully enclosed, one person cab of galvanneal steel structure with acoustical insulation.

Equipped with:

- Tinted and tempered glass windows
- Extra-large fixed front window with windshield wiper and washer
- Swing up roof window with windshield wiper
- Sliding left side door with large fixed window
- Sliding rear and right side windows for ventilation
- Six way adjustable, cushioned seat with seat belt and storage compartment
- Engine dependent warm-water heater with air ducts for front windshield defroster and cab floor
- Defroster fan for the front window
- Bubble level
- Circulating fan
- Adjustable sun visor
- Dome light
- Cup holder
- Fire extinguisher
- Left side viewing mirror
- Pull-out cabwalk
- Two position travel swing lock

**Air Conditioning – Optional** – Integral with cab heating system utilizing the same ventilation outlets

**Armrest Controls** – Two dual axis hydraulic joystick controllers or optional single axis hydraulic controllers for:

- Swing
- Boom hoist
- Main rear winch
- Auxiliary front winch – optional
- Drum rotation indication
- Drum rotation indicator activation switch
- Winch high/low speed and disable switch(es)
- Counterweight handling switch
- Telescopic override switches
- Warning horn button
- Swing park brake

**Outrigger Controls** – Hand held control box with umbilical cord gives the operator the freedom to view operation while setting the outriggers.

**Foot Controls**

- Boom telescope
- Swing brake
- Engine throttle



### Right Front Console – Controls and indicators for:

- Engine ignition
- Engine throttle lock
- Function disable
- Front windshield wiper and washer
- Cab floodlights
- Warning horn
- Heating controls
- Console dimmer switch
- Bubble level
- 12 volt power connection
- Air conditioning – optional
- Boom floodlight – optional
- Rotating beacon/Strobe light – optional

### Cab Instrumentation – Ergonomically positioned, analog instrumentation for crane operation including:

- Check and stop engine indicators
- Engine coolant temperature with warning indicator
- Hydraulic oil temperature with warning indicator
- Fuel level with warning indicator
- Tachometer

### Rated Capacity Limiter – Microguard graphic audio–visual warning system integrated into the dash with anti–two block and function limiter. Operating data available includes:

- Crane configuration
- Boom length and angle
- Boom head height
- Allowed load and % of allowed load
- Boom angle
- Radius of load
- Actual load
- Presetable defined alarms (include):
  - Maximum and minimum boom angles
  - Maximum tip height
  - Maximum boom length
  - Swing left/right positions
  - Operator defined area (imaginary plane)

**Internal RCL Light Bar – Optional** – Visually informs the operator when crane is approaching maximum load capacity with a series of green, yellow, and red lights.

**External RCL Light Bar – Optional** – Visually informs the ground crew when crane is approaching maximum load capacity with a series of green, yellow, and red lights.

### ■ Swing

**Motor/Planetary** – Bi–directional hydraulic swing motor mounted to a planetary reducer for 360° continuous smooth swing at 1.7 rpm.

**Swing Park Brake** – 360°, electric over hydraulic, (spring applied/hydraulic released) multi–disc brake mounted on the speed reducer. Operated by a toggle switch from the operator’s cab.

**Swing Brake** – 360°, foot operated, hydraulic applied disc brake mounted to the speed reducer.

**Swing Lock** – Two–position swing lock (boom over front or rear) operated from the operator’s cab.

**360° Positive Swing Lock – Optional** – Meets New York City requirement.

### ■ Electrical

**Swing Alarm** – Audio warning device signals when the upper is swinging.

### Lights

- Two working lights on front of the cab
- One rotating amber beacon on top of the cab – optional
- One amber strobe beacon on top of the cab – optional
- Boom floodlight – optional

## ■ Load Hoist System Load Hoist Performance

Main (Rear) and Auxiliary (Front) Winches – 3/4 in (19mm) Rope

Layer	Maximum Line Pull		Normal Line Speed		High Line Speed		Layer		Total	
	lb	kg	ft/min	m/min	ft/min	m/min	ft	m	ft	m
1	16,506	7 487.0	176	53.6	352	107.3	114	34.7	114	34.7
2	15,175	6 883.4	192	58.5	383	116.7	124	37.8	238	72.5
3	14,043	6 369.9	207	63.1	414	126.2	134	40.8	372	113.4
4	13,068	5 927.6	223	68.0	445	135.6	144	43.9	516	157.3
5	12,220	5 543.0	238	72.5	476	145.1	154	46.9	670	204.2

Wire Rope Application		Diameter		Type	Maximum Permissible Load	
		in	mm		lb	kg
Main (Rear) Winch	Standard	3/4	19	18x19 rotation resistant – right regular lay (Type RB)	12,920	5 860.5
	Optional	3/4	19	36x7 rotation resistant – right regular lay (Type ZB)	15,600	7 076.2
Auxiliary (Front) Winch	Standard	3/4	19	18x19 rotation resistant – right regular lay (Type RB)	12,920	5 860.5
	Optional	3/4	19	36x7 rotation resistant – right regular lay (Type ZB)	15,600	7 076.2



## 2M Main and Optional Auxiliary Winches

- Axial piston, full and half displacement (2–speed) motors driven through planetary reduction unit for positive control under all load conditions.
- Combined winch mode merges the hydraulic flow of two pumps for high–speed operation for either the main or auxiliary winch.
- Grooved lagging
- Power up/down mode of operation
- Hoist drum cable follower
- Drum rotation indicator
- Drum diameter: 16 in (40.6cm)
- Rope length:
  - Main: 630 ft (192.0m)
  - Auxiliary: 630 ft (192.0m)
- Maximum rope storage: 834 ft (254.2m)
- Terminator style socket and wedge

## Hydraulic System

**Counterbalance Valves** – All hoist motors, boom extend cylinders, and boom hoist cylinder are equipped with counterbalance valves to provide load lowering and to prevent accidental load drop if hydraulic power is suddenly reduced.

**Hydraulic Oil Cooler** – Remote mounted cooler with hydraulically driven fan removes heat from the hydraulic oil. Located behind the operator’s cab.

**Boom Hoist Float Valves (Optional)** – For transporting the boom over the rear of the crane with a boom dolly. Allows hydraulic oil within the boom hoist cylinder to flow between piston side and case side.

**Swing Brake Release** – For transporting the boom over the rear of the crane with a boom dolly. Holds the 360° swing park brake in the released position allowing free rotation of the upper structure.

## Counterweight

**Standard** – Total of 12,000 lb (5 445kg) of total counterweight consisting of three, hydraulically removable 4,000 lb (1 815kg) counterweights with capacities for 0 lb (0kg), 4,000 lb (1 815kg), 8,000 lb (3 630kg), and 12,000 lb (5 445kg) counterweight configurations. Assembled and disassembled by hydraulic cylinders controlled from the left side of the upper structure.

**Optional** – 4,000 lb (1 815kg) in addition to standard counterweight for a total of 16,000 lb (7 260kg)

**Counterweight Usage Combinations**

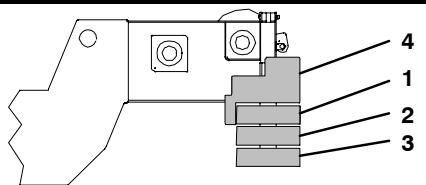

Cwt	Standard				Optional
	0 lb (0kg)	4,000 lb (1 815kg)	8,000 lb (3 630kg)	12,000 lb (5 445kg)	16,000 lb (7 260kg)
1		X	X	X	X
2			X	X	X
3				X	X
4					X



## Carrier

### General

- 8 ft 6 in (2.6 m) wide
- 23 ft 9.2 in (7.24m) wheelbase (centerline of first axle to fourth axle)
- **Frame** – Box–type, torsion resistant, welded construction made of high tensile steel. Equipped with front and rear towing and tie–down lugs, tow connections, and access ladders.

### Outriggers

**Boxes** – Two double box, front and rear welded to the carrier frame

**Beams and Jacks** – Four dual stage beams with Confined Area Lifting Capacities (CALC) provide selectable outrigger extensions of full, intermediate, and retracted positions. Hydraulically controlled from the operator’s cab and on both sides of carrier with integral check valves. A fifth front bumper outrigger with integral check valve is hydraulically controlled from the operator’s cab and at the front bumper of carrier.

**Pontoons** – Four lightweight, stow’n go, 23.5” x 27.25” (59.7 x 69.2cm) hexagonal steel pontoons with a contact area of 485 in<sup>2</sup> (3 129cm<sup>2</sup>) can be stored for road travel in either the storage racks on the carrier or under the outrigger boxes.

**Main Jack Reaction** – 97,400 lb (44 180.6kg) force and 200.8 psi (1 384.5kPa) ground bearing pressure

### Steering and Axles

- Sheppard full integral master gear/slave gear steering system provides hydraulic assisted steering with mechanical link between steering wheel and wheels
- **Drive** – 8 x 4 for on/off–highway travel
- **Axle 1 & 2** – Tandem steered, non–driven
- **Axle 3 & 4** – Tandem non–steered, driven with reduction: 6.17 to 1
- **Inter–Axle Differential Lock** – Traction adding device that locks axle 3 with axle 4. Operated by a switch from the carrier cab.

### Suspension

**Front** – Four 9–leaf springs with center equalizers

**Rear** – Raydan Air Link walking beam air suspension with height adjustment. The rear of the carrier can be lowered with a switch in the carrier cab.

- **Axle Lift System** – Improves rear tire ground clearance when the crane is up on outriggers.

### Tires and Wheels

**Front** – Four (single) 445/65R22.5 tires on aluminum disc wheels

- **Rear** – Eight (dual) 12R22.5 tires on aluminum disc wheels
- Spare tires and wheels – optional
- Tire inflation kit – optional

### Brakes

**Service** – Full air brakes on all wheel ends. Dual circuit compressed air system with air dryer.

**Parking/Emergency** – Spring loaded type, acting on 3rd and 4th axles automatically apply when air pressure drops below 40 psi (275.8kPa) in both circuits.

### Electrical

**Battery** – Four batteries provide 12 volt starting and operation

#### Lights

- Front lighting includes two main headlights, two high beam lights, two parking/directional indicators, and three cab marker lights.
- Side lighting includes three parking/directional indicators per side.
- Rear lighting includes two parking/directional indicators, two parking/brake lights, two reverse lights, three marker lights, and a license plate light.
- Other equipment includes hazard/warning system, cab light, instrument panel light, and signal horn.
- One amber strobe beacon on top of the cab – optional
- Daytime running lights – optional

### Engine

Specification	Detroit Diesel Series 60
Numbers of cylinders	6
Cycle	4
Bore and Stroke: inch (mm)	5.12 x 6.30 (130x160)
Piston Displacement: in <sup>3</sup> (L)	778 (12.7)
Max. Brake Horsepower: hp (kW)	378 (281.9) @ 1,800 rpm 375 (279.6) @ 2,100 rpm
Peak Torque: ft lb (J)	1,350 (1 831) @ 1,200 rpm
Alternator: volts – amps	12 – 130
Crankcase Capacity: qt (L)	32 (30.3)
<ul style="list-style-type: none"> <li>• Cruise control</li> <li>• Three–stage engine compression brake</li> <li>• Thermostatically controlled, hydraulically driven radiator fan</li> <li>• 120 volt engine block heater</li> <li>• Ether injection system – optional</li> </ul>	

### Transmission

**Manual** – Eaton RTO–14909ALL has 11 forward gears and 3 reverse gears.

**Carrier Speeds and Gradeability**

Eaton		Speed			Gradeability (@ Peak Torque Except Creep @ Idle)
Gear	Ratio	mph	km/h	% Grade	
8th	High Range	.73	58.4	94.0	2.1
7th		1.00	42.6	68.6	3.4
6th		1.38	30.9	49.7	5.1
5th		1.95	21.9	35.2	7.6
Reverse		3.43	12.4	19.8	10.9
4th	Low Range	2.77	15.4	24.8	11.2
3rd		3.79	11.2	18.1	15.6
2nd		5.23	8.2	13.1	21.8
1st		7.41	5.8	9.3	31.1
Low		16.30	2.6	4.2	54.5
Reverse		13.01	3.3	5.2	43.4
LL2	Deep Reduction	11.85	3.6	5.8	50.2
LL1		26.08	1.6	2.6	54.0
Reverse		20.82	2.1	3.3	43.0
LL1 @ 700 rpm		26.08	0.5	0.9	51.2
Reverse @ 700 rpm		20.82	0.7	1.1	40.7

Based on a gross vehicle weight of 95,000 lb (43 091kg)

**Fuel Tank**

One 100 gal (378.5L) capacity tank

**Hydraulic System****Main Pumps**

- Five fixed displacement gear pumps for the main outriggers, main and auxiliary winches, swing, boom hoist, and telescope with manual disconnect for use when crane is in travel mode
- One fixed displacement gear pump for steering and the fifth front bumper outrigger
- One variable displacement piston pump for the controls circuit
- One fixed displacement gear pump for engine cooling fan
- Combined pump capacity of 195 gpm (738.2Lpm)

**Hydraulic Reservoir** – 169 gal (639.7L) capacity equipped with sight level gauge. Diffusers built in for deaeration.

**Filtration** – One 10 micron, full flow, return line filter. All oil is filtered prior to return to reservoir. Accessible for easy filter replacement.

**Pump Drive**

All functions are hydraulically powered allowing positive, precise control with independent or simultaneous operation of all functions.

**Lower Cab and Controls**

**Environmental Ultra–Cab** – Fully enclosed, one person cab of composite structure with acoustical insulation.

Equipped with:

- Tinted and tempered glass windows
- Roll down left side window for ventilation
- Sliding rear and right side windows for ventilation
- Windshield wiper and washer
- Six way adjustable and air suspended driver's seat with seat belt
- Two adjustable rear view mirrors
- Engine dependent warm–water heater with air ducts for windshield defroster and cab floor
- Adjustable sun visor
- Dome light
- 12 volt connection
- Fire extinguisher

**Air Conditioning – Optional** – Integral with cab heating system utilizing the same ventilation outlets.



**Cab Instrumentation** – Ergonomically positioned analog instrumentation for driving including:

- Speedometer with odometer, hourmeter, trip odometer, and clock
- Front and rear air pressure with warning indicator
- Engine coolant temperature with warning indicator
- Engine oil pressure with warning indicator
- Voltage indicator with warning indicator
- Fuel level
- Tachometer

**Right Side Console – Controls For:**

- Transmission gear shifting
- Cruise control
- Engine compression brake

**Dash Mounted Controls For:**

- Check and stop engine indicators
- Windshield wipers and washers
- Carrier lights and turn indicators
- Carrier/upper throttle control
- Engine cooling fan override
- Cab heater/air conditioning
- Console dimmer switch
- Engine diagnostic switch
- Warning lamps
- Engine ignition

**Dash Mounted Indicators For:**

- Check, stop, and service engine
- Turn signal indication
- Park brake
- Cruise activation
- High beam headlights

**Foot Controls For:**

- Carrier service brakes
- Engine throttle
- Transmission clutch

## ■ Additional Equipment

**Standard:**

- Aluminum full deck fenders with mud flaps
- Left and right bubble levels
- Air hose connection ports
- Clearance flags

**Optional:**

- Pneumatic and electrical quick disconnect connectors mounted on the rear for trailer or boom dolly brakes and lights
- Left side aluminum storage box
- Rear mounted pintle hook



## Axle Loads

Base crane with full tank of fuel and no counterweight	Gross Vehicle Weight ( <sup>1</sup> )		Front Axles		Rear Axles	
	lb	kg	lb	kg	lb	kg
	76,617	34 753	34,763	15 768	41,854	18 985
Driver in the carrier cab	250	113	315	143	-65	-30
Rear pintle hook	25	11	-11	-5	36	16
Pneumatic and electrical connectors for trailer or boom dolly	7	3	-3	-1	10	5
Carrier aluminum storage box	57	26	16	7	41	19
Ether injection	13	6	12	5	1	0.5
Air conditioning – carrier cab	42	19	51	23	-9	-4
Auxiliary winch with 630 ft (192.0m) of 3/4 in (19mm) type “RB” rope	855	388	-274	-124	1,129	512
Remove 630 ft (192.0m) of rope – main winch	-702	-318	338	153	-1,040	-472
Remove 630 ft (192.0m) of rope – auxiliary winch	-702	-318	254	115	-956	-434
Air conditioning – upper operator’s cab	120	54	-4	-2	124	56
360° mechanical swing lock	140	64	22	10	118	54
One slab of counterweight on upper	4,000	1 815	-2,094	-950	6,094	2 764
Two slabs of counterweight on upper	8,000	3 630	-4,187	-1 899	12,187	5 528
Three slabs of counterweight on upper	12,000	5 445	-6,281	-2 849	18,281	8 292
Three slabs and two cheek weights of counterweight on upper	16,000	7 260	-8,374	-3 798	24,374	11 056
Floodlight to the front of the boom base section	10	5	17	8	-7	-3
Fly mounting brackets to boom base section for fly options	160	73	148	67	12	5
36.5 ft (11.1m) offsettable lattice fly – stowed	1,542	699	1,338	607	204	93
36.5–61 ft (11.1–18.6m) offsettable lattice fly – stowed	2,248	1 020	1,700	771	548	249
Auxiliary lifting sheave	125	57	231	105	-106	-48
40 ton (36.3mt) 4 sheave hook block at front bumper	720	327	1,163	528	-443	-201
60 ton (54.4mt) 4 sheave hook block at front bumper	1,109	503	1,791	812	-682	-309
75 ton (68.0mt) 5 sheave hook block at front bumper	1,400	635	2,261	1 026	-861	-391
8.5 ton (7.7mt) hook ball at front bumper	360	163	581	264	-221	-100

Counterweight Load Transfer	Front Axles		Rear Axles	
	lb	kg	lb	kg
Transfer one slab of counterweight to carrier deck	5,264	2 388	-5,264	-2 388
Transfer two slabs of counterweight to carrier deck	10,528	4 775	-10,528	-4 775
Transfer three slabs of counterweight to carrier deck	15,792	7 163	-15,792	-7 163

Axle	Maximum Load @ 65 mph (105km/h)
Front	46,400 lb (21 047kg) – aluminum disc wheels with 445/65R22.5 tires
Rear	50,350 lb (22 838kg) – aluminum disc wheels with 12R22.5 tires

(<sup>1</sup>) Adjust gross vehicle weight and axle loading according to component weight.

Note: All weights are ±3%.



## Axle Loads with 2–Axle Boom Dolly

Base crane and 5,700 lb (2 585kg) boom dolly with full tank of fuel and no counterweight	Gross Vehicle Weight <sup>(1)</sup>		Front Axles		Rear Axles		Dolly Axles	
	lb	kg	lb	kg	lb	kg	lb	kg
	82,317	37 338	30,472	13 822	33,936	15 393	17,909	8 123
Driver in the carrier cab	250	113	315	143	-65	-30	0	0
Rear pintle hook	25	11	-11	-5	36	16	0	0
Pneumatic and electrical connectors for trailer or boom dolly	7	3	-3	-1	10	5	0	0
Carrier aluminum storage box	57	26	16	7	41	19	0	0
Ether injection	13	6	12	5	1	0.5	0	0
Air conditioning – carrier cab	42	19	51	23	-9	-4	0	0
Auxiliary winch with 630 ft (192.0m) of 3/4 in (19mm) type “RB” rope	855	388	588	267	267	121	0	0
Remove 630 ft (192.0m) of rope – main winch	-702	-318	-527	-239	-175	-79	0	0
Remove 630 ft (192.0m) of rope – auxiliary winch	-702	-318	-443	-201	-259	-117	0	0
Air conditioning – upper operator’s cab	120	54	-4	-2	124	56	0	0
360° mechanical swing lock	140	64	16	7	124	56	0	0
One slab of counterweight on carrier deck	4,000	1 815	3,171	1 438	829	376	0	0
Two slabs of counterweight on carrier deck	8,000	3 630	6,341	2 876	1,659	753	0	0
Three slabs of counterweight on carrier deck	12,000	5 445	9,512	4 315	2,488	1 129	0	0
Three slabs and two cheek weights of counterweight on carrier deck	16,000	7 260	12,682	5 752	3,318	1 505	0	0
Floodlight to the front of the boom base section	10	5	-1	-0.5	-1	-0.5	11	5
Fly mounting brackets to boom base section for fly options	160	73	29	13	29	13	103	47
36.5 ft (11.1m) offsettable lattice fly – stowed	1,542	699	225	102	227	103	1,090	494
36.5–61 ft (11.1–18.6m) offsettable lattice fly – stowed	2,248	1 020	409	186	412	187	1,427	647
Auxiliary lifting sheave	125	57	-20	-9	-20	-9	165	75
40 ton (36.3mt) 4 sheave hook block at front bumper	720	327	-97	-44	-98	-44	915	415
60 ton (54.4mt) 4 sheave hook block at front bumper	1,109	503	-150	-68	-151	-68	1,410	640
75 ton (68.0mt) 5 sheave hook block at front bumper	1,400	635	-189	-86	-191	-87	1,780	807
8.5 ton (7.7mt) hook ball at front bumper	360	163	-58	-26	-58	-26	476	216

Counterweight Load Transfer	Front Axles		Rear Axles		Dolly Axles	
	lb	kg	lb	kg	lb	kg
Transfer two slabs of counterweight to boom dolly	-6,341	-2 876	-1,659	753	8,000	3 629

<sup>(1)</sup> Adjust gross vehicle weight and axle loading according to component weight.  
Note: All weights are ±3%.



# General Dimensions

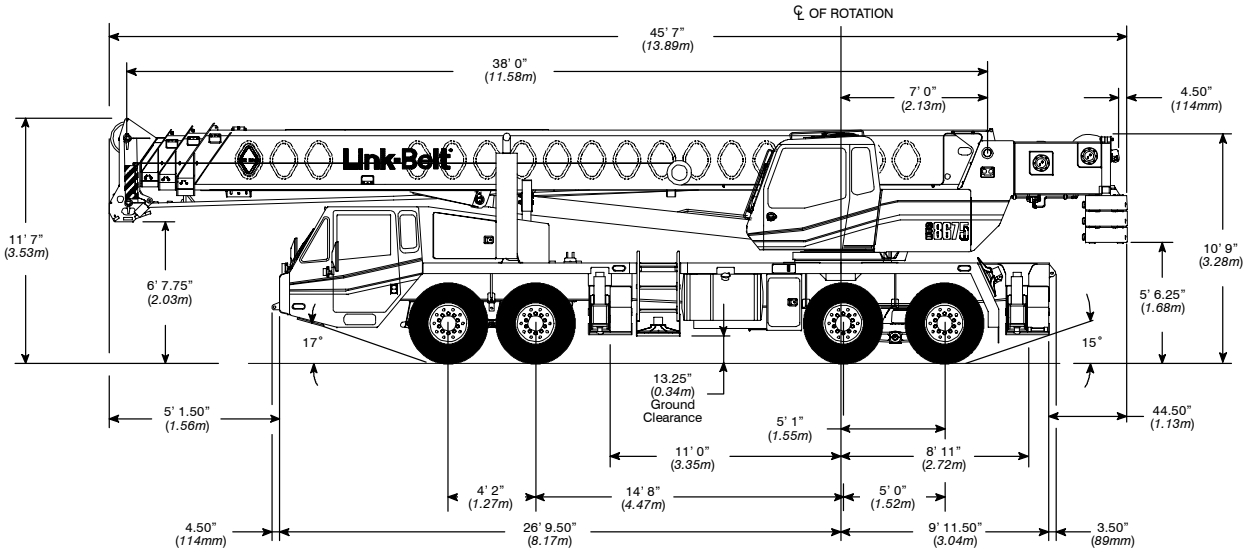

Turning Radius	English	Metric
Wall to wall over carrier	46' 3"	14.1m
Wall to wall over boom	47' 1"	14.4m
Wall to wall over boom attachment	49' 2"	15.0m
Curb to curb	41' 10"	12.8m
Centerline of tire	41' 1"	12.5m

Tail Swing	English	Metric
With counterweight	13' 8"	4.2m
Without counterweight	13' 1"	4.0m

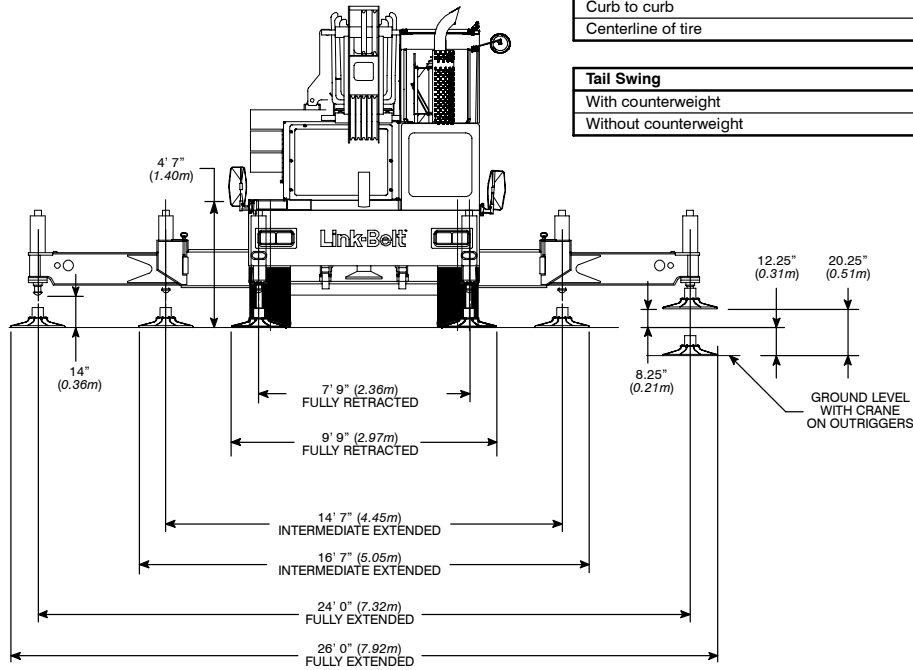

Not To Scale

# Working Range Diagram

**Working Range Diagram  
On Fully Extended Outriggers**

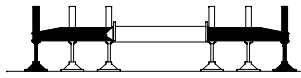

**12,000 lb (5 445kg)  
Counterweight**

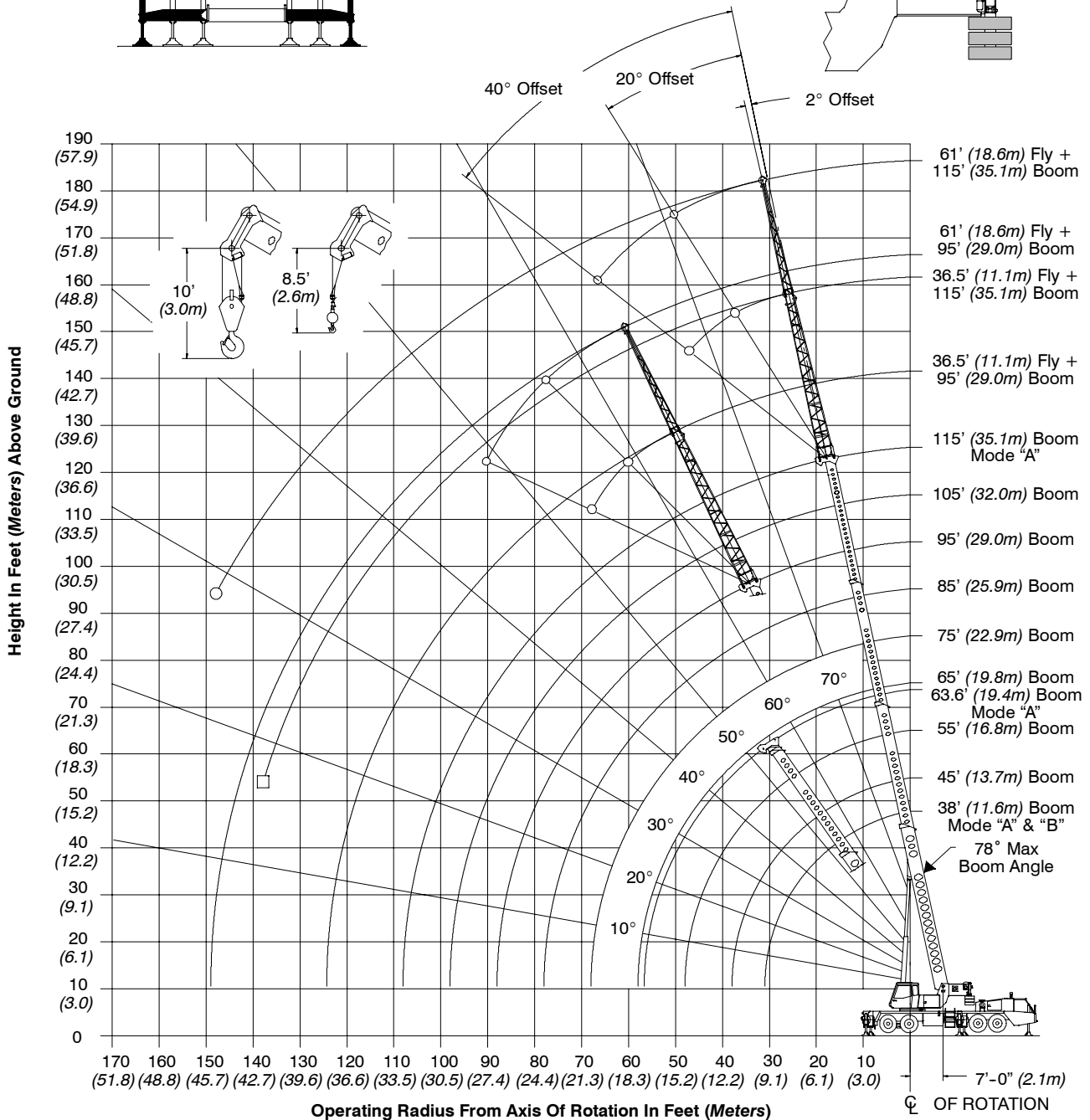
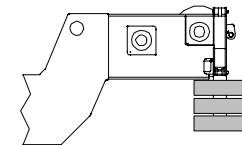

- Denotes Main Boom + 61' (18.6m) Fly–Boom Mode "B"
- Denotes Main Boom + 36.5' (11.1m) Fly–Boom Mode "B"



# Boom Extend Modes

## Boom Mode “A” (A-max)

Only inner mid section telescopes.

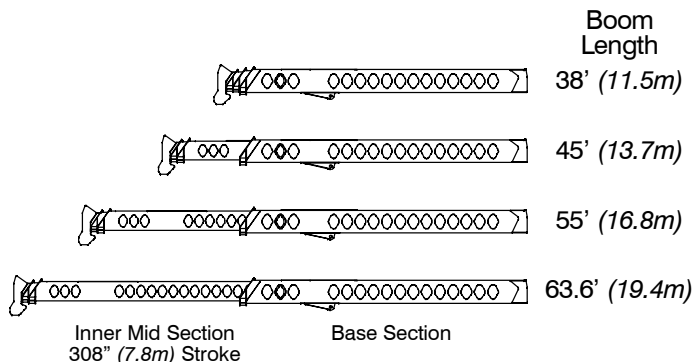

## Boom Mode “B” (Standard)

Inner mid, outer mid, and tip sections telescope simultaneously.

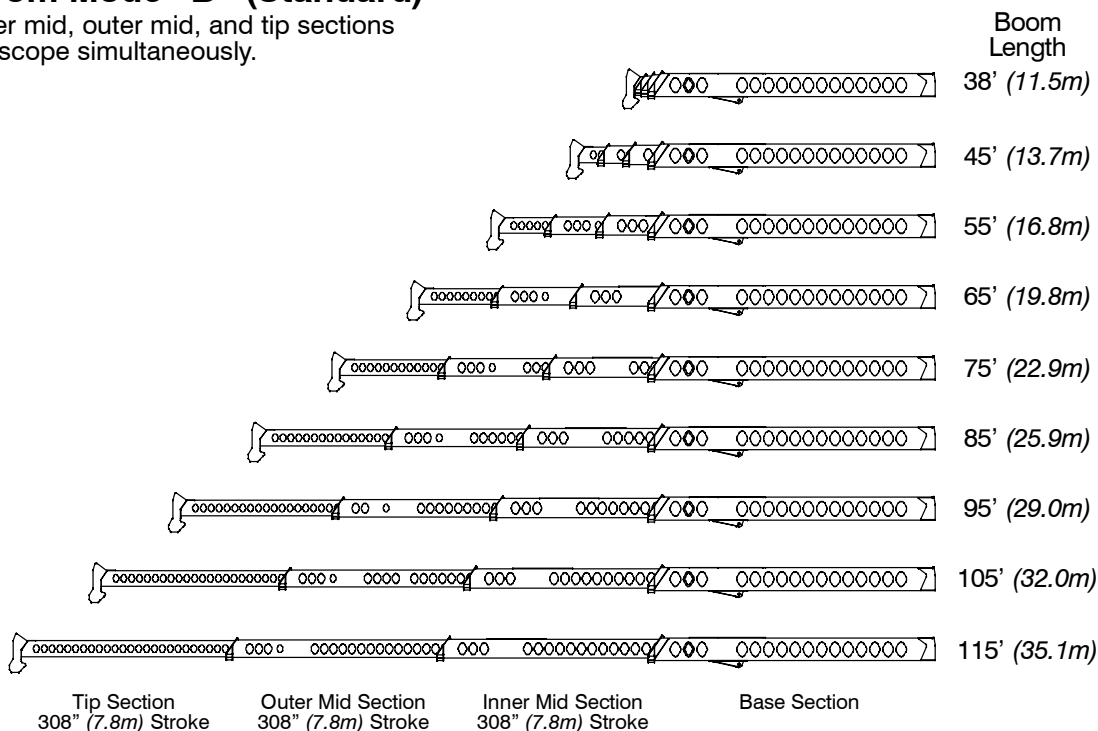



## Main Boom Lift Capacity Charts – Standard

12,000 lb Counterweight – Fully Extended Outriggers – 360° Rotation (All Capacities Are Listed In Pounds)										
Radius (ft)	Boom Length (ft)									Radius (ft)
	38	45	55	63.6/65	75	85	95	105	115	
8	150,000*									8
9	140,000*									9
10	132,000	87,400	85,600							10
12	114,600	87,400	85,600	56,300**						12
15	98,200	87,400	85,600	56,300**	42,000	42,000				15
20	73,600	73,200	72,700	53,000**	42,000	42,000	38,600			20
25	56,700	56,300	55,900	44,900**	42,000	41,800	33,800	30,300	24,500	25
30	41,900	41,600	40,900	42,000	42,000	36,900	29,800	27,000	24,500	30
35		31,700	31,300	33,800	34,000	32,900	26,600	24,100	22,200	35
40			24,700	27,100	27,300	27,400	23,900	21,700	20,000	40
45			19,800	22,200	22,500	22,600	21,700	19,600	18,100	45
50				18,500	18,800	18,900	19,000	17,900	16,300	50
55				15,600	15,900	16,000	16,100	16,200	14,900	55
60					13,500	13,700	13,800	13,900	13,600	60
65					11,600	11,800	11,900	12,000	12,000	65
70						10,100	10,200	10,300	10,400	70
75						8,700	8,800	8,900	9,000	75
80							7,600	7,700	7,800	80
85							6,500	6,600	6,700	85
90								5,700	5,800	90
95								4,900	5,000	95
100									4,300	100
105									3,700	105

\* Special Conditions Or Wire Rope Required  
\*\* 63.6 A – max Mode

This information is not for crane operation. Operator must refer to the in-cab information for crane operation. Rated lifting capacities shown on fully extended outriggers do not exceed 85% of the tipping loads and on tires do not exceed 75% of the tipping loads.



<b>12,000 lb Counterweight – On Tires – Stationary – Boom Centered Over Rear</b> (All Capacities Are Listed In Pounds)							
Radius (ft)	Boom Length (ft)						Radius (ft)
	38	45	55	65	75	85	
10	32,800						10
12	29,700						12
15	25,800	25,800					15
20	20,700	20,700	20,700				20
25	16,800	16,800	16,800	16,800			25
30	12,800	13,500	14,000	14,400	14,600		30
35		10,100	10,700	11,100	11,300	11,500	35
40			8,200	8,600	8,800	9,000	40
45			6,300	6,700	6,900	7,100	45
50				5,200	5,400	5,600	50
55				3,900	4,200	4,400	55
60					3,200	3,400	60
65						2,500	65

<b>12,000 lb Counterweight – On Tires – Pick &amp; Carry (1 mph) – Boom Centered Over Rear</b> (All Capacities Are Listed In Pounds)							
Radius (ft)	Boom Length (ft)						Radius (ft)
	38	45	55	65	75	85	
10	20,700						10
12	19,000						12
15	16,200	16,200					15
20	12,400	12,400	12,400				20
25	9,500	9,500	9,500	9,500			25
30	7,200	7,200	7,200	7,200	7,200		30
35		5,800	5,800	5,800	5,800	5,800	35
40			4,800	4,800	4,800	4,800	40
45			3,500	3,500	3,500	3,500	45
50				2,800	2,800	2,800	50
55				1,900	1,900	1,900	55
60					1,400	1,400	60
65						700	65

This information is not for crane operation. Operator must refer to the in-cab information for crane operation. Rated lifting capacities shown on fully extended outriggers do not exceed 85% of the tipping loads and on tires do not exceed 75% of the tipping loads.



## Main Boom Lift Capacity Charts – Optional

16,000 lb Counterweight – Fully Extended Outriggers – 360° Rotation (All Capacities Are Listed In Pounds)										
Radius (ft)	Boom Length (ft)									Radius (ft)
	38	45	55	63.6/65	75	85	95	105	115	
8	150,000*									8
9	140,000*									9
10	132,000	87,400	85,600							10
12	116,900	87,400	85,600	56,300**						12
15	100,200	87,400	85,600	56,300**	42,000	42,000				15
20	75,900	75,500	75,000	53,000**	42,000	42,000	38,600			20
25	58,700	58,300	57,900	44,900**	42,000	41,800	33,800	30,300	24,500	25
30	45,400	45,100	44,400	42,000	42,000	36,900	29,800	27,000	24,500	30
35		35,600	36,300	36,600	36,800	32,900	26,600	24,100	22,200	35
40			29,100	29,400	29,600	29,700	23,900	21,700	20,000	40
45			23,800	24,300	24,500	24,600	21,700	19,600	18,100	45
50				20,300	20,600	20,700	19,800	17,900	16,300	50
55				17,200	17,500	17,600	17,700	16,200	14,900	55
60					15,000	15,100	15,200	14,900	13,600	60
65					12,900	13,100	13,200	13,300	12,500	65
70						11,400	11,600	11,600	11,600	70
75						9,900	10,100	10,200	10,300	75
80							8,800	8,900	9,000	80
85							7,700	7,800	7,800	85
90								6,800	6,900	90
95								5,900	6,000	95
100									5,200	100
105									4,600	105

\* Special Conditions Or Wire Rope Required  
\*\* 63.6 A – max Mode

This information is not for crane operation. Operator must refer to the in-cab information for crane operation. Rated lifting capacities shown on fully extended outriggers do not exceed 85% of the tipping loads and on tires do not exceed 75% of the tipping loads.



<b>16,000 lb Counterweight – On Tires – Stationary – Boom Centered Over Rear</b> (All Capacities Are Listed In Pounds)							
Radius (ft)	Boom Length (ft)						Radius (ft)
	38	45	55	65	75	85	
10	32,800						10
12	29,700						12
15	25,800	25,800					15
20	20,700	20,700	20,700				20
25	16,800	16,800	16,800	16,800			25
30	13,700	13,700	13,700	13,700	13,700		30
35		11,500	12,100	12,500	12,700	12,800	35
40			9,400	9,800	10,000	10,200	40
45			7,400	7,700	8,000	8,200	45
50				6,100	6,400	6,600	50
55				4,800	5,100	5,200	55
60					4,000	4,200	60
65					3,100	3,200	65
70						2,500	70

<b>16,000 lb Counterweight – On Tires – Pick &amp; Carry (1 mph) – Boom Centered Over Rear</b> (All Capacities Are Listed In Pounds)							
Radius (ft)	Boom Length (ft)						Radius (ft)
	38	45	55	65	75	85	
10	20,700						10
12	19,000						12
15	16,200	16,200					15
20	12,400	12,400	12,400				20
25	9,500	9,500	9,500	9,500			25
30	7,200	7,200	7,200	7,200	7,200		30
35		5,800	5,800	5,800	5,800	5,800	35
40			4,800	4,800	4,800	4,800	40
45			3,500	3,500	3,500	3,500	45
50				2,800	2,800	2,800	50
55				1,900	1,900	1,900	55
60					1,400	1,400	60
65					700	700	65
70						300	70

This information is not for crane operation. Operator must refer to the in-cab information for crane operation. Rated lifting capacities shown on fully extended outriggers do not exceed 85% of the tipping loads and on tires do not exceed 75% of the tipping loads.



## Fly Attachment Lift Capacity Charts – Optional

12,000 lb Counterweight – Fully Extended Outriggers – 360° Rotation (All Capacities Are Listed In Pounds)								
115 ft Main Boom Length 2° Fly Offset			115 ft Main Boom Length 20° Fly Offset			115 ft Main Boom Length 40° Fly Offset		
Radius (ft)	Fly Length (ft)		Radius (ft)	Fly Length (ft)		Radius (ft)	Fly Length (ft)	
	36.5	61		36.5	61		36.5	61
35	10,500		45	9,200		55	6,800	
40	10,500	7,100	50	8,900		60	6,600	
45	10,500	7,100	55	8,600		65	6,500	
50	10,500	7,100	60	8,200	4,900	70	6,300	
55	10,500	7,000	65	8,000	4,700	75	6,200	
60	10,500	6,700	70	7,700	4,500	80	6,100	3,300
65	10,200	6,400	75	7,400	4,300	85	6,000	3,200
70	9,500	6,200	80	7,200	4,200	90	5,900	3,100
75	8,700	5,900	85	7,000	4,000	95	5,800	3,000
80	8,000	5,600	90	6,800	3,900	100	5,700	3,000
85	7,400	5,300	95	6,500	3,700	105	5,400	2,900
90	6,800	5,100	100	5,800	3,600	110	4,700	2,900
95	6,000	4,800	105	5,100	3,500	115	4,100	2,800
100	5,200	4,600	110	4,500	3,400	120	3,500	2,800
105	4,600	4,400	115	3,900	3,300	125		2,800
110	4,000	4,200	120	3,400	3,200	130		2,700
115	3,500	4,000	125	2,900	3,100	135		2,700
120	3,000	3,500	130	2,400	3,000	140		2,700
125	2,600	3,100	135	2,000	2,800	145		2,300
130	2,200	2,700	140	1,600	2,400			
135	1,900	2,300	145		2,100			
140		2,000	150		1,700			
145		1,700	155		1,400			
150		1,400						

This information is not for crane operation. Operator must refer to the in-cab information for crane operation. Rated lifting capacities shown on fully extended outriggers do not exceed 85% of the tipping loads and on tires do not exceed 75% of the tipping loads.



16,000 lb Counterweight – Fully Extended Outriggers – 360° Rotation (All Capacities Are Listed In Pounds)								
115 ft Main Boom Length 2° Fly Offset			115 ft Main Boom Length 20° Fly Offset			115 ft Main Boom Length 40° Fly Offset		
Radius (ft)	Fly Length (ft)		Radius (ft)	Fly Length (ft)		Radius (ft)	Fly Length (ft)	
	36.5	61		36.5	61		36.5	61
35	10,500		45	9,200		55	6,800	
40	10,500	7,100	50	8,900		60	6,600	
45	10,500	7,100	55	8,600		65	6,500	
50	10,500	7,100	60	8,200	4,900	70	6,300	
55	10,500	7,000	65	8,000	4,700	75	6,200	
60	10,500	6,700	70	7,700	4,500	80	6,100	3,300
65	10,200	6,400	75	7,400	4,300	85	6,000	3,200
70	9,500	6,200	80	7,200	4,200	90	5,900	3,100
75	8,700	5,900	85	7,000	4,000	95	5,800	3,000
80	8,000	5,600	90	6,800	3,900	100	5,700	3,000
85	7,400	5,300	95	6,500	3,700	105	5,700	2,900
90	6,900	5,100	100	6,100	3,600	110	5,400	2,900
95	6,400	4,800	105	5,600	3,500	115	4,900	2,800
100	5,900	4,600	110	5,200	3,400	120	4,300	2,800
105	5,500	4,400	115	4,700	3,300	125		2,800
110	4,900	4,200	120	4,100	3,200	130		2,700
115	4,300	4,000	125	3,600	3,100	135		2,700
120	3,800	3,800	130	3,100	3,000	140		2,700
125	3,300	3,400	135	2,700	2,900	145		2,700
130	2,900	3,100	140	2,300	2,800			
135	2,500	2,900	145		2,500			
140	2,200	2,600	150		2,300			
145		2,300	155		2,000			
150		2,000	160		1,600			
155		1,700						
160		1,400						

This information is not for crane operation. Operator must refer to the in-cab information for crane operation. Rated lifting capacities shown on fully extended outriggers do not exceed 85% of the tipping loads and on tires do not exceed 75% of the tipping loads.



## Main Boom Lift Capacity Charts – Optional (Metric)

5 445kg Counterweight – Fully Extended Outriggers – 360° Rotation (All Capacities Are Listed In Kilograms)										
Radius (m)	Boom Length (m)									Radius (m)
	11.58	13.7	16.8	19.39/19.8	22.9	25.9	29.0	32.0	35.05	
2.44	68 000*									2.44
3.0	60 000	39 600	38 800							3.0
3.5	54 000	39 600	38 800							3.5
4.0	49 200	39 600	38 800	25 500**						4.0
4.5	45 100	39 600	38 800	25 500**						4.5
5.0	41 400	37 800	37 150	25 100**	19 050	19 050				5.0
6.0	34 050	33 600	33 350	24 100**	19 050	19 050				6.0
7.0	27 350	27 150	26 850	21 850**	19 050	18 950	16 200			7.0
8.0	21 650	21 400	21 100	19 300**	18 650	18 400	14 850	13 350	11 100	8.0
9.0	17 400	17 300	17 500	17 600	17 650	16 950	13 650	12 350	11 100	9.0
10.0		14 850	15 100	15 250	15 300	15 000	12 700	11 500	10 500	10.0
12.0			11 000	11 150	11 250	11 300	10 950	9 950	9 150	12.0
14.0			8 300	8 600	8 700	8 750	8 800	8 650	8 050	14.0
16.0				6 800	6 900	6 950	7 000	7 050	6 900	16.0
18.0					5 600	5 650	5 700	5 750	5 750	18.0
20.0					4 500	4 600	4 650	4 650	4 700	20.0
22.0						3 750	3 800	3 850	3 850	22.0
24.0							3 150	3 200	3 200	24.0
26.0							2 600	2 600	2 650	26.0
28.0								2 150	2 150	28.0
30.0									1 800	30.0
32.0									1 450	32.0

\* Special Condition Or Wire Rope Required  
\*\* 19.39 A–max Mode

This information is not for crane operation. Operator must refer to the in-cab information for crane operation. Rated lifting capacities shown on fully extended outriggers do not exceed 75% of the tipping loads and on tires do not exceed 65% of the tipping loads.



<b>5 445kg Counterweight – On Tires – Stationary – Boom Centered Over Rear</b> (All Capacities Are Listed In Kilograms)							
Radius (m)	Boom Length (m)						Radius (m)
	11.58	13.7	16.8	19.8	22.9	25.9	
3.0	14 850						3.0
3.5	13 850						3.5
4.0	12 850						4.0
4.5	11 850						4.5
5.0	11 100	11 100					5.0
6.0	9 550	9 550					6.0
7.0	7 950	8 100	8 250				7.0
8.0	6 500	6 700	6 950	7 100			8.0
9.0	5 200	5 450	5 700	5 850			9.0
10.0		4 550	4 750	4 900	5 000		10.0
12.0			3 300	3 450	3 550	3 650	12.0
14.0			2 350	2 500	2 600	2 650	14.0
16.0				1 750	1 850	1 950	16.0
18.0					1 300	1 350	18.0
20.0						950	20.0

<b>5 445kg Counterweight – On Tires – Pick &amp; Carry (1.6km/h) – Boom Centered Over Rear</b> (All Capacities Are Listed In Kilograms)							
Radius (m)	Boom Length (m)						Radius (m)
	11.58	13.7	16.8	19.8	22.9	25.9	
3.0	9 400						3.0
3.5	8 850						3.5
4.0	8 150						4.0
4.5	7 450						4.5
5.0	6 900	6 900					5.0
6.0	5 750	5 750					6.0
7.0	4 850	4 850	4 850				7.0
8.0	4 050	4 050	4 050	4 050			8.0
9.0	3 350	3 350	3 350	3 350			9.0
10.0		2 900	2 900	2 900	2 900		10.0
12.0			2 250	2 250	2 250	2 250	12.0
14.0			1 500	1 500	1 550	1 550	14.0
16.0				1 100	1 100	1 100	16.0
18.0					650	650	18.0
20.0						250	20.0

This information is not for crane operation. Operator must refer to the in-cab information for crane operation. Rated lifting capacities shown on fully extended outriggers do not exceed 75% of the tipping loads and on tires do not exceed 65% of the tipping loads.



## Main Boom Lift Capacity Charts – Optional (Metric)

7 260kg Counterweight – Fully Extended Outriggers – 360° Rotation (All Capacities Are Listed In Kilograms)										
Radius (m)	Boom Length (m)									Radius (m)
	11.58	13.7	16.8	19.39/19.8	22.9	25.9	29.0	32.0	35.05	
2.44	68 000*									2.44
3.0	60 000	39 600	38 800							3.0
3.5	54 800	39 600	38 800							3.5
4.0	50 150	39 600	38 800	25 500**						4.0
4.5	46 050	39 600	38 800	25 500**						4.5
5.0	42 350	38 100	37 450	25 100**	19 050	19 050				5.0
6.0	35 100	34 550	34 300	24 100**	19 050	19 050				6.0
7.0	28 850	28 650	28 350	21 850**	19 050	18 950	16 200			7.0
8.0	23 350	23 100	22 800	19 650**	19 000	18 400	14 850	13 350	11 100	8.0
9.0	18 850	18 650	18 750	18 850	18 950	16 950	13 650	12 350	11 100	9.0
10.0		16 100	16 350	16 500	16 550	15 600	12 700	11 500	10 500	10.0
12.0			12 000	12 100	12 200	12 250	10 950	9 950	9 150	12.0
14.0			9 100	9 400	9 500	9 550	9 550	8 700	8 050	14.0
16.0				7 450	7 600	7 600	7 650	7 600	7 050	16.0
18.0					6 150	6 200	6 250	6 300	6 200	18.0
20.0					5 050	5 150	5 200	5 250	5 250	20.0
22.0						4 300	4 350	4 400	4 400	22.0
24.0							3 650	3 650	3 700	24.0
26.0							3 050	3 050	3 100	26.0
28.0								2 550	2 600	28.0
30.0									2 150	30.0
32.0									1 800	32.0

\* Special Conditions Or Wire Rope Required  
\*\* 19.39 A –max Mode

This information is not for crane operation. Operator must refer to the in-cab information for crane operation. Rated lifting capacities shown on fully extended outriggers do not exceed 75% of the tipping loads and on tires do not exceed 65% of the tipping loads.



<b>7 260kg Counterweight – On Tires – Stationary – Boom Centered Over Rear (All Capacities Are Listed In Kilograms)</b>							
Radius (m)	Boom Length (m)						Radius (m)
	11.58	13.7	16.8	19.8	22.9	25.9	
3.0	14 850						3.0
3.5	13 850						3.5
4.0	12 850						4.0
4.5	11 850						4.5
5.0	11 100	11 100					5.0
6.0	9 550	9 550					6.0
7.0	8 350	8 350	8 350				7.0
8.0	7 150	7 200	7 250	7 300			8.0
9.0	5 900	6 100	6 300	6 400			9.0
10.0		5 150	5 350	5 500	5 600		10.0
12.0			3 850	3 950	4 050	4 100	12.0
14.0			2 750	2 900	3 000	3 100	14.0
16.0				2 150	2 200	2 300	16.0
18.0					1 600	1 700	18.0
20.0					1 100	1 200	20.0

<b>7 260kg Counterweight – On Tires – Pick &amp; Carry (1.6km/h) – Boom Centered Over Rear (All Capacities Are Listed In Kilograms)</b>							
Radius (m)	Boom Length (m)						Radius (m)
	11.58	13.7	16.8	19.8	22.9	25.9	
3.0	9 400						3.0
3.5	8 850						3.5
4.0	8 150						4.0
4.5	7 450						4.5
5.0	6 900	6 900					5.0
6.0	5 750	5 750					6.0
7.0	4 850	4 850	4 850				7.0
8.0	4 050	4 050	4 050	4 050			8.0
9.0	3 350	3 350	3 350	3 350			9.0
10.0		2 900	2 900	2 900	2 900		10.0
12.0			2 250	2 250	2 250	2 250	12.0
14.0			1 500	1 550	1 550	1 550	14.0
16.0				1 100	1 100	1 100	16.0
18.0					650	650	18.0
20.0					250	250	20.0

This information is not for crane operation. Operator must refer to the in-cab information for crane operation. Rated lifting capacities shown on fully extended outriggers do not exceed 75% of the tipping loads and on tires do not exceed 65% of the tipping loads.



## Fly Attachment Lift Capacity Charts – Optional (Metric)

5 445kg Counterweight – Fully Extended Outriggers – 360° Rotation (All Capacities Are Listed In Kilograms)								
35.05m Main Boom Length 2° Fly Offset			35.05m Main Boom Length 20° Fly Offset			35.05m Main Boom Length 40° Fly Offset		
Radius (m)	Fly Length (m)		Radius (m)	Fly Length (m)		Radius (m)	Fly Length (m)	
	11.13	18.59		11.13	18.59		11.13	18.59
12.0	4 750		12.0			12.0		
14.0	4 750	3 200	14.0	4 100		14.0		
16.0	4 750	3 150	16.0	3 950		16.0		
18.0	4 750	3 050	18.0	3 750		18.0	3 000	
20.0	4 550	2 850	20.0	3 600	2 100	20.0	2 900	
22.0	4 150	2 750	22.0	3 400	2 000	22.0	2 800	
24.0	3 600	2 550	24.0	3 250	1 900	24.0	2 750	
26.0	3 050	2 350	26.0	3 150	1 800	26.0	2 700	1 400
28.0	2 550	2 250	28.0	2 850	1 700	28.0	2 650	1 350
30.0	2 150	2 100	30.0	2 400	1 600	30.0	2 500	1 350
32.0	1 800	1 950	32.0	2 000	1 550	32.0	2 150	1 300
34.0	1 500	1 700	34.0	1 700	1 500	34.0	1 800	1 300
36.0	1 250	1 450	36.0	1 400	1 450	36.0	1 450	1 250
38.0	1 050	1 200	38.0	1 100	1 400	38.0		1 250
40.0	800	1 000	40.0	900	1 200	40.0		1 200
42.0	650	800	42.0	700	1 000	42.0		1 100
44.0		650	44.0		800	44.0		900
46.0		500	46.0		650	46.0		

This information is not for crane operation. Operator must refer to the in-cab information for crane operation. Rated lifting capacities shown on fully extended outriggers do not exceed 75% of the tipping loads and on tires do not exceed 65% of the tipping loads.



7 260kg Counterweight – Fully Extended Outriggers – 360° Rotation (All Capacities Are Listed In Kilograms)								
35.05m Main Boom Length 2° Fly Offset			35.05m Main Boom Length 20° Fly Offset			35.05m Main Boom Length 40° Fly Offset		
Radius (ft)	Fly Length (m)		Radius (m)	Fly Length (m)		Radius (m)	Fly Length (m)	
	11.13	18.59		11.13	18.59		11.13	18.59
12.0	4 750		12.0			12.0		
14.0	4 750	3 200	14.0	4 100		14.0		
16.0	4 750	3 150	16.0	3 950		16.0		
18.0	4 750	3 050	18.0	3 750		18.0	3 000	
20.0	4 550	2 850	20.0	3 600	2 100	20.0	2 900	
22.0	4 150	2 750	22.0	3 400	2 000	22.0	2 800	
24.0	3 700	2 550	24.0	3 250	1 900	24.0	2 750	
26.0	3 300	2 350	26.0	3 150	1 800	26.0	2 700	1 400
28.0	2 950	2 250	28.0	3 000	1 700	28.0	2 650	1 350
30.0	2 550	2 100	30.0	2 750	1 600	30.0	2 600	1 350
32.0	2 150	1 950	32.0	2 400	1 550	32.0	2 500	1 300
34.0	1 850	1 850	34.0	2 000	1 500	34.0	2 100	1 300
36.0	1 550	1 750	36.0	1 700	1 450	36.0	1 800	1 250
38.0	1 300	1 550	38.0	1 450	1 400	38.0		1 250
40.0	1 100	1 300	40.0	1 200	1 300	40.0		1 200
42.0	900	1 100	42.0	950	1 250	42.0		1 200
44.0		900	44.0		1 100	44.0		1 100
46.0		750	46.0		850	46.0		900
48.0		600	48.0		700	48.0		
50.0			50.0		500	50.0		

This information is not for crane operation. Operator must refer to the in-cab information for crane operation. Rated lifting capacities shown on fully extended outriggers do not exceed 75% of the tipping loads and on tires do not exceed 65% of the tipping loads.



5480 (supersedes 5456) – 0706 – F2

**Link-Belt Construction Equipment Company**      Lexington, Kentucky      [www.linkbelt.com](http://www.linkbelt.com)

®Link-Belt is a registered trademark. Copyright 2006. We are constantly improving our products and therefore reserve the right to change designs and specifications.

**Bigge Crane and Rigging Co.**

10700 Bigge Avenue  
San Leandro, CA 94577  
Phone: (888) 337-BIGGE or (510) 638-8100  
Fax: (510) 639-4053  
Email: [info@bigge.com](mailto:info@bigge.com)  
Web site: [www.bigge.com](http://www.bigge.com)

HTC-8675

Link-Belt Cranes