



# TR-6005XL-3

60 Ton Capacity (54 Metric Tons)

## HYDRAULIC ROUGH TERRAIN CRANE

### DIMENSIONS

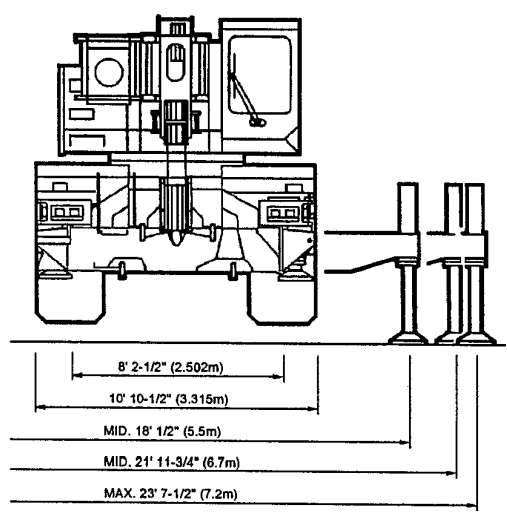
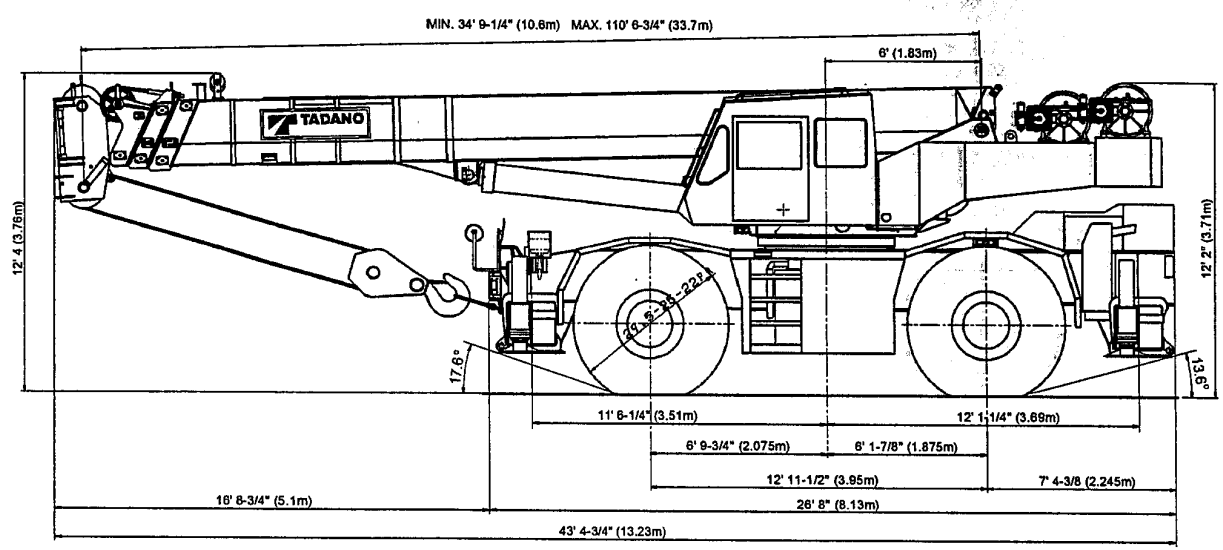

Note: Dimension is with boom angle at -1.5 degree.

### GENERAL DIMENSIONS (29.5 x 25 Tires)

	Feet	Meters
Turning radius:		
4 wheel steer	21' 11-3/4"	6.7
2 wheel steer	39' 1/2"	11.9
Tail swing of counterweight	13' 6-1/4"	4.12

Specifications are subject to change without notice.

## CRANE SPECIFICATIONS

### BOOM

Four section full power partially synchronized telescoping boom of hexagonal box construction 34.8'-110.6' (10.6m-33.7m) with five sheaves, 17-1/4" (0.438m) root diameter, at boom head. The synchronization system consists of two telescope cylinders fitted with holding valves, an extension cable and retraction cable. Two easily removable wire rope guards, rope dead end provided on right side of boom head. Boom telescope sections are supported by wear pads both vertically and horizontally.

**BOOM ELEVATION** - By a double acting hydraulic cylinder with holding valve. Elevation -1.5°-80°, combination controls for hand or foot operation. Boom angle indicator.

**JIB** - Box top section telescopes from lattice type base section which stores alongside base boom section. 5° or 30° offset (tilt type). Single sheave, 17-1/4" (0.438m) root diameter, at jib head. Jib length is 32.2 (9.8m) or 56.1' (17.1m).

**AUXILIARY LIFTING SHEAVE (SINGLE TOP)** - Single sheave, 17-1/4" (0.438m) root diameter. Mounted to main boom head for single line work (stowable).

**ANTI-TWO BLOCK** - Pendant type over-winding cut out device with audio-visual (FAILURE lamp/BUZZER) warning system.

### SWING

Hydraulic axial piston motor driven through planetary swing speed reducer. Continuous 360° full circle swing on ball bearing turntable at 2.4 rpm. Equipped with manually locked/released swing brake. A swing lock (360° positive swing lock) for pick and carry and travel modes, manually engaged in cab.

### HOIST

**MAIN HOIST** - Variable speed type with grooved drum driven by hydraulic axial piston motor through winch speed reducer. Power load lowering and raising. Equipped with automatic brake (neutral brake) and counterbalance valve. Controlled independently of auxiliary hoist. Equipped with cable follower and drum rotation indicator.

**DRUM** - Grooved 15-3/4" (0.400m) root diameter x 22-3/4" (0.578m) wide. Wire rope: 623' of 3/4" diameter rope (190m of 19mm). Drum capacity: 905' (276m) 6 layers. Maximum line pull (permissible): 14,272 lbs. (6,474kg)\*. Maximum line speed: 525 FPM (160m/min).

**AUXILIARY HOIST** - Variable speed type with grooved drum driven by hydraulic axial piston motor through winch speed reducer. Power load lowering and raising. Equipped with automatic brake (neutral brake) and counterbalance valve. Controlled independently from main hoist. Equipped with cable follower and drum rotation indicator.

**DRUM** - Grooved 15-3/4" (0.400m) root diameter x 22-3/4" (0.578m) wide. Wire rope: 361' of 3/4" diameter rope (110 m of 19mm). Drum capacity: 905' (276m) 6 layers. Maximum line pull (permissible): 14,272 lbs. (6,474kg)\*. Maximum line speed: 525 FPM (160m/min).

\* Maximum permissible line pull may be affected by wire rope strength.

**WIRE ROPE** - Filler wire, extra improved plow steel, pre-formed, independent wire rope core, right regular lay. 3/4" (19 mm) 6x37 class

### HOOK BLOCKS

1. 50 ton (45.4 metric ton) - 4 sheaves with swivel hook and safety latch, for 3/4" (19mm) wire rope.
2. 6.2 ton (5.6 metric ton) - Weighted hook with swivel and safety latch, for 3/4" (19mm) wire rope.

### HYDRAULIC SYSTEM

**PUMPS** - Two variable piston pumps for crane functions. Tandem gear pump for steering, swing and optional equipment. Powered by carrier engine. Pump disconnect for crane is engaged/ disengaged by rotary switch from operator's cab.

**CONTROL VALVES** - Multiple valves actuated by hand levers with integral pressure relief valves.

**RESERVOIR** - 195 gallon (740 lit.) capacity. External sight level gauge.

**FILTRATION** - 26 micron return filter, full flow with bypass protection, located inside of hydraulic reservoir. Accessible for easy replacement.

**OIL COOLER** - Air cooled fan type.

### CAB AND CONTROLS

Both crane and drive operations can be performed from one cab mounted on rotating superstructure.

Left side, 1 man type, steel construction with sliding door access and safety glass windows opening at side, rear and roof. Windshield glass window is shatter-resistant. Tilt-telescoping steering wheel. Adjustable control levers for swing, boom hoist, boom telescoping, auxiliary hoist and main hoist. Control levers for swing and auxiliary hoist can change neutral positions and tilt for easy access to cab. Engine throttle knob. Foot operated controls: boom hoist, boom telescoping, service brake and engine throttle.

Dash-mounted engine start/stop, monitor lamps, cigarette lighter, parking brake switch, steering mode select switch, pump engaged/disengaged switch, swing brake switch, and telescoping correction switches.

Instruments - Torque converter oil temperature, engine water temperature, air pressure, fuel, speedometer, tachometer and hour meter. Torque converter oil pressure and hydraulic oil pressure are monitored and displayed on the AML-L display panel.



Tadano electronic LOAD MOMENT INDICATOR system (AML-L) including:

- Control lever lockout function
- Load radius and/or boom angle preset function (warning only)
- Warning buzzer
- Boom angle/boom length/jib offset angle/load radius/rated lifting capacities/actual loads read out
- Ratio of actual load moment to rated load moment indication
- Working condition register switch
- External warning lamp
- TADANO AML-L monitors outrigger extended length and automatically programs the corresponding "Rated Lifting Capacities" for crane duty in confined areas.

Operator's right hand console includes transmission gear selector, outrigger controls, sight level bubble, drive selector switch, swing free-lock selector switch, working light switch and ashtray. Swing lock lever and 3 way adjustable seat with high back and seat belt.

NOTE: Each crane motion speed is based on unladen conditions.

## CARRIER SPECIFICATIONS

**TYPE** - Rear engine, left hand steering, driving axle 2-way selected type by manual switch, 4x2 front drive, 4x4 front and rear drive.

**FRAME** - High tensile steel, all welded mono-box construction.

**TRANSMISSION** - Electronically controlled full automatic transmission. Torque converter driving full powershift with driving axle selector. 6 forward and 2 reverse speeds, constant mesh.

- 3 speeds - high range - 2 wheel drive; 4 wheel drive
- 3 speeds - low range - 4 wheel drive

**TRAVEL SPEED** - 25 mph (40 km/h)

**AXLE** - Front: Full floating type, steering and driving axle with planetary reduction. Rear: Pivot-mounted, steering and driving axle with planetary reduction and non-spin rear differential.

**STEERING** - Hydraulic power steering controlled by steering wheel. Three steering modes available: 2 wheel front, 4 wheel coordinated and 4 wheel crab.

**SUSPENSION** - Front: Rigid mounted to frame. Rear: Pivot mounted with hydraulic lockout cylinders.

**BRAKE SYSTEMS** - Service: Air over hydraulic disc brakes on all 4 wheels. Parking/Emergency: Spring applied-air released brake acting on input shaft of front axle.

**TIRES** - 29.5-25-22PR(OR)

**OUTRIGGERS** - Four hydraulic, beam and jack outriggers. Vertical jack cylinders equipped with integral holding valve. Each outrigger beam and jack is controlled independently from cab. Beams extend to 23' 7-1/2" (7.2 m) center-line and retract to within 10' 10-1/2" (3.315 m) overall width with floats. Outrigger jack floats are attached thus eliminating the need of manually attaching and detaching them. Controls and sight bubble located in upper structure cab.

Three outrigger extension lengths are provided with corresponding "Rated Lifting Capacities" for crane duty in confined areas.

- Mid. Extension 18'1/2" center to center floats
- Mid. Extension 21'11-3/4" center to center floats
- Max. extension 23'7-1/2" center to center floats

### ENGINE

Model	Mitsubishi 6D16-TLEA
Type	Direct injection diesel
No. of cylinders	6
Combustion	4 cycle, turbo charged and after cooled
BoreXStroke, in.(mm)	4.646 X 4.528 (118X115)
Displacement, cu. in. (liters)	460 (7.545)
Air inlet heater	24 volt preheat
Air cleaner	Dry type, replaceable element
Oil filter	Full flow with replaceable element
Fuel filter	Full flow with replaceable element
Fuel tank, gal.(liters)	79.2 (300), right side of carrier
Cooling	Liquid pressurized, recirculating by-pass

Radiator	Fin and tube core, thermostat controlled
Fan, in.(mm)	Suction type, 6-blade, 23.6 (600) dia.
Starting	24 volt
Charging	24 volt system, negative ground
Battery	2-120 amp. Hour
Compressor, air, CFM(l./min)	10.6 CFM (301) at 2,000rpm
Horsepower (kW)	Gross 247 (184) at 2,800rpm
Torque, Max. ft-lb (kgm)	521 (72) at 1,400rpm
Capacity, gal.(liters)	
Cooling water	3.4 (13)
Lubrication	3.7 ~ 4.2 (14 ~ 16)
Fuel	79.2 (300)

## STANDARD EQUIPMENT

- Four section full power partially synchronized boom 34.8'-110.6' (10.6 m-33.7 m)
- Two stage stowable telescoping jib 32.2' (9.8 m) or 56.1' (17.1m) with 5° or 30° pinned offset (tilt type) with self storing pins
- Auxiliary lifting sheave (single top) stowable
- Boom hoist foot control
- Boom telescoping foot control
- Boom angle indicator
- Variable speed main hoist with grooved drum, cable follower and 623' of 3/4 cable
- Variable speed Auxiliary hoist with grooved drum, cable follower and 361' of 3/4 cable
- Drum rotation indicator (thumper type) main and auxiliary hoist
- Tadano twin swing system
- 360° positive swing lock
- 4 X 4 X 4 drive/steer
- Disc Brakes
- Automatic rear axle oscillation lockout system
- Non-spin rear differential
- 29.5-25-22PR (OR) tires
- Independently controlled outriggers
- Self-storing outrigger pads
- Three outrigger extension positions
- Outrigger extension length detector
- Outrigger hose protection
- Mitsubishi 6D16-TLEA Turbo Charged after cooled engine (247 HP) with exhaust brake
- Electronic controlled Automatic transmission driven by torque converter
- Engine over-run alarm
- Complete highway light package
- Anti-Two block device (overwind cutout)
- Electronic crane monitoring system
- Tadano electronic load moment indicator system (AML-L) including
  - Control lever lockout function
  - Working radius and/or boom angle and/or tip height preset function (warning only)
  - Warning buzzer
  - Boom angle / boom length / jib offset angle / working radius / rated loads / actual loads read out
- Ratio of actual load moment to rated load moment indication
- Working condition register switch
- External warning lamp
- Tinted safety glass
- Front windshield wiper and washer
- Roof window wiper and washer
- Roof window lock warning
- Rear view mirrors (right and left side)
- Mirror for main and auxiliary hoists
- 3 way adjustable seat with high back and seat belt
- Tilt-telescoping steering wheel
- Neutral position adjustable control lever (swing and aux. hoist)
- Cab floor mat
- Cigarette lighter
- Electric fan in cab
- Back-up alarm
- Low oil pressure/high water temp. warning device (visual)
- Rear steer centering light
- Fenders
- Air cleaner dust indicator
- Towing hooks-Front and rear
- Lifting eyes
- Tool storage compartment
- Full instrumentation package
- Pump disconnect in operator's cab
- Air dryer
- Water separator with filter
- Flood lights and work lights
- Tire inflation kit
- Hydraulic oil cooler
- 24 volt electric system
- 50 ton (45.4 metric ton) 4 sheave hook block
- 6.2 ton (5.6 metric ton) hook with swivel
- Hook block tie down (front bumper)

## OPTIONAL EQUIPMENT

- Hydraulic oil driven cab heater and air conditioner
- Propane heater (less tank)

## HOISTING SPECIFICATIONS

### LINE SPEEDS AND PULLS

Layer	Speed	Main or auxiliary hoist - 15'-3/4" (0.4m) drum					
		Line speeds <sup>2</sup>		Line pulls			
		F.P.M	m/min	Available <sup>1</sup>		Permissible <sup>4</sup>	
				Lbs.	kgf	Lbs.	kgf
1st	Low	180	55	15,698	7,121	14,272	6,474
	High	361	110				
2nd	Low	197	60	14,647	6,644	13,315	6,040
	High	394	120				
3rd	Low	213	65	13,520	6,133	12,292	5,576
	High	427	130				
4th	Low	230	70	12,557	5,696	11,416	5,179
	High	460	140				
5th	Low	246	75	11,721	5,317	10,657	4,834
	High	492	150				
6th <sup>3</sup>	Low	262	80	10,989	4,985	9,991	4,532
	High	525	160				

<sup>1</sup> Developed by machinery with first layer of wire rope, but not based on rope strength or other limitation in machinery or equipment.  
<sup>2</sup> Line speeds based only on hook block, not loaded.  
<sup>3</sup> Sixth layer of wire rope is not recommended for hoisting operations.  
<sup>4</sup> Permissible line pull may be affected by wire rope strength.

### DRUM WIRE ROPE CAPACITIES

Wire rope layer	Main and auxiliary drum grooved lagging			
	3/4" (19mm) wire rope			
	Rope per layer		Total wire rope	
	Feet	Meters	Feet	Meters
1	123.0	37.5	123.0	37.5
2	134.2	40.9	257.2	78.4
3	145.3	44.3	402.5	122.7
4	156.5	47.7	559.0	170.4
5	167.7	51.1	726.7	221.5
6	178.8	54.5	905.5	276.0

### DRUM DIMENSIONS

	Inch	mm
Root diameter	15-3/4"	400
Length	22-3/4"	578
Flange diameter	25-3/8"	645



# TR-6005XL-3 WORKING RANGE CHART

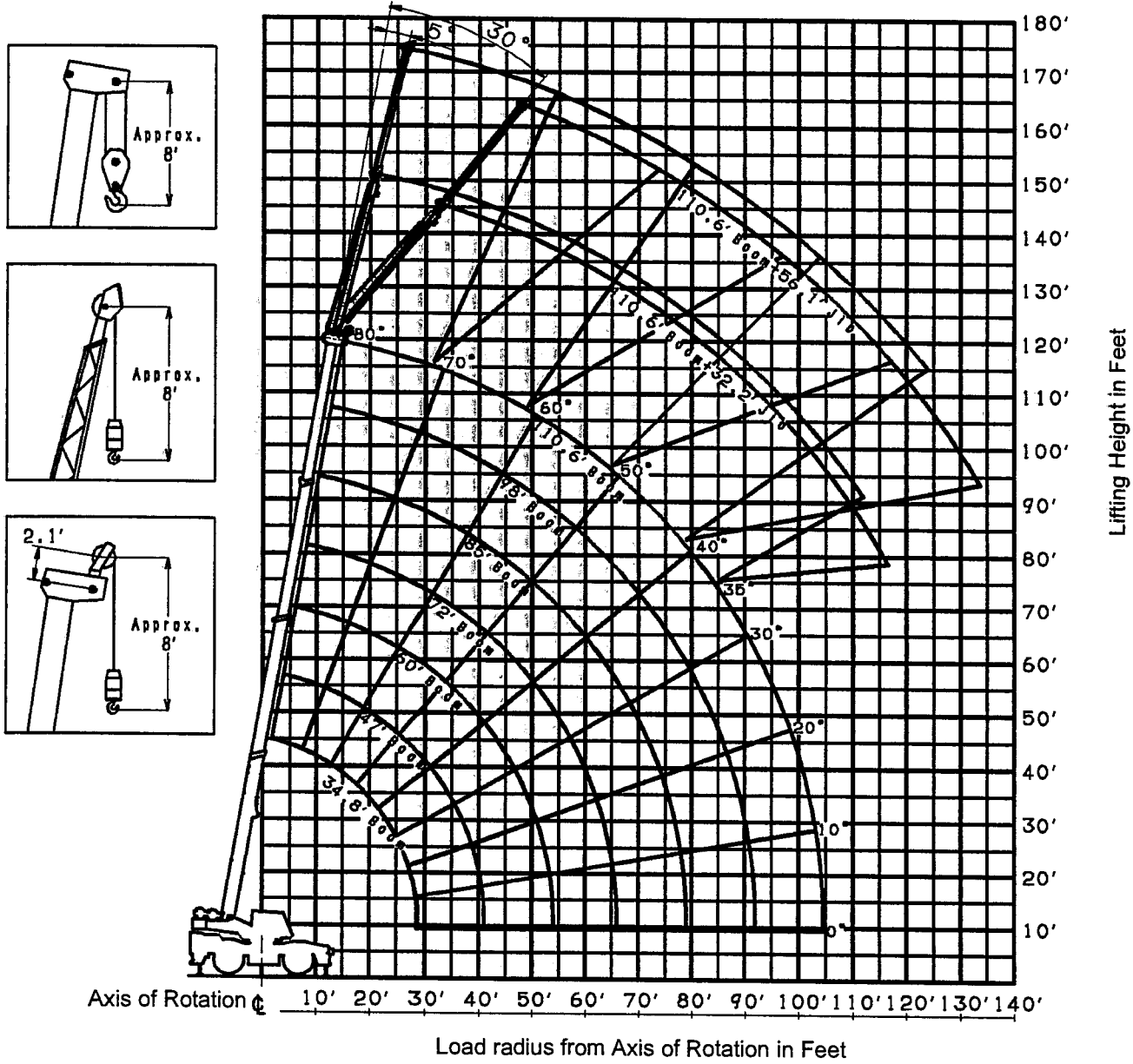

**NOTE:** Boom and jib geometry shown are for unloaded condition and machine standing level on firm supporting surface. Boom deflection and subsequent radius and boom angle change must be accounted for when applying load to hook.



## TR-6005XL-3 RATED LIFTING CAPACITIES (IN POUNDS)

ON OUTRIGGERS FULLY EXTENDED																
360° ROTATION																
A	34.8' (10.6m)	47' (14.3m)	60' (18.3m)	72' (21.9m)	85' (25.9m)	98' (29.9m)	110.6' (33.7m)	Boom Angle in Degree	110.6 (33.7m) Boom + 32.2 (9.8m) Jib				110.6 (33.7m) Boom + 56.1 (17.1m) Jib			
									5° offset		30° offset		5° offset		30° offset	
B	R		W		R		W		R		W		R		W	
10'	120,000	88,200	68,000													
12'	92,600	87,200	63,500	40,700												
15'	77,500	77,000	57,800	40,700	38,800			80°	25.6	11,000	37.4	5,500	33.0	6,100	54.1	2,300
20'	59,700	59,200	47,400	40,700	38,000	32,300		75°	38.8	9,200	49.7	4,900	48.6	5,000	68.5	2,200
25'	47,700	47,200	40,000	35,300	31,200	27,800	24,200	70°	50.9	7,000	61.7	4,400	62.9	4,100	81.9	1,900
30'		38,600	33,900	29,800	26,200	23,300	21,000	65°	62.3	5,500	72.5	3,800	76.9	3,500	94.4	1,800
35'		30,300	28,700	25,500	22,500	20,000	18,200	60°	73.4	4,500	82.9	3,300	89.7	2,800	106.0	1,700
40'		23,700	22,500	22,400	19,600	17,300	15,800	55°	83.7	3,700	92.3	2,900	102.0	2,300	116.0	1,600
45'			17,700	19,500	17,200	15,200	13,900	50°	93.4	3,200	101.0	2,600	113.0	1,900	126.0	1,400
50'			14,400	15,700	15,200	13,500	12,300	45°	102.0	2,800	109.0	2,300	123.0	1,600	134.0	1,300
55'				12,900	13,500	12,000	11,000	40°	110.0	2,400	115.0	1,900	132.0	1,300	141.0	1,200
60'				10,600	11,400	10,800	9,700	35°	117.0	1,700	121.0	1,600				
65'				9,000	9,400	9,500	8,700									
70'					8,100	8,100	7,900									
75'					7,000	6,900	7,100									
80'						6,200	6,400									
85'						5,400	5,600									
90'						4,800	4,800									
95'							3,900									
100'							3,300									
104'							2,500									
C	0°															

A: Boom length in feet  
 B: Load radius in feet  
 C: Minimum boom angle (deg.) for indicated length (no load)  
 R: Load radius in feet  
 W: Rated lifting capacity in pounds

ON OUTRIGGERS MID. EXTENDED 21'11-3/4" (6.7m) SPREAD																
360° ROTATION																
A	34.8' (10.6m)	47' (14.3m)	60' (18.3m)	72' (21.9m)	85' (25.9m)	98' (29.9m)	110.6' (33.7m)	Boom Angle in Degree	110.6 (33.7m) Boom + 32.2 (9.8m) Jib				110.6 (33.7m) Boom + 56.1 (17.1m) Jib			
									5° offset		30° offset		5° offset		30° offset	
B	R		W		R		W		R		W		R		W	
10'	120,000	88,200	68,000													
12'	92,600	87,200	63,500	40,700												
15'	77,500	77,000	57,800	40,700	38,800			80°	25.6	11,000	37.4	5,500	33.0	6,100	54.1	2,300
20'	59,700	59,200	47,400	40,700	38,000	32,300		75°	38.8	9,200	49.7	4,900	48.6	5,000	68.5	2,200
25'	47,700	47,200	40,000	35,300	31,200	27,800	24,200	70°	50.9	7,000	61.7	4,400	62.9	4,100	81.9	1,900
30'		34,100	33,600	29,800	26,200	23,300	21,000	65°	62.3	5,500	72.5	3,800	76.9	3,500	94.4	1,800
35'		25,100	24,700	25,500	22,500	20,000	18,200	60°	73.4	4,500	82.9	3,300	89.7	2,800	106.0	1,700
40'		19,300	18,700	20,000	19,600	17,300	15,800	55°	83.7	3,700	92.3	2,900	102.0	2,300	116.0	1,600
45'			14,500	15,600	16,900	15,200	13,900	50°	93.4	3,200	101.0	2,600	113.0	1,900	126.0	1,400
50'			11,500	12,800	13,600	13,500	12,300	45°	102.0	2,800	108.0	1,800	123.0	1,400	134.0	1,100
55'				10,400	11,200	11,400	11,000	40°	110.0	1,200	115.0	1,100				
60'				8,400	9,100	9,500	9,700	35°								
65'				6,900	7,500	7,900	8,200									
70'					6,100	6,600	6,800									
75'					5,100	5,500	5,900									
80'						4,700	5,000									
85'						3,800	4,100									
90'						3,100	3,400									
95'							2,700									
100'							2,200									
104'							1,800									
C	0°															

A: Boom length in feet  
 B: Load radius in feet  
 C: Minimum boom angle (deg.) for indicated length (no load)  
 R: Load radius in feet  
 W: Rated lifting capacity in pounds



### TR-6005XL-3 RATED LIFTING CAPACITIES (IN POUNDS)

ON OUTRIGGERS MID. EXTENDED 18' 1/2" (5.5m) SPREAD																
360° ROTATION																
A B	34.8' (10.6m)	47' (14.3m)	60' (18.3m)	72' (21.9m)	85' (25.9m)	98' (29.9m)	110.6' (33.7m)	Boom Angle in Degree	110.6' (33.7m) Boom + 32.2 (9.8m) Jib				110.6' (33.7m) Boom + 56.1 (17.1m) Jib			
									5° offset		30° offset		5° offset		30° offset	
								R	W	R	W	R	W	R	W	
10'	120,000	88,200	68,000													
12'	92,600	87,200	63,500	40,700												
15'	77,500	77,000	57,800	40,700	38,800			80°	25.6	11,000	37.4	5,500	33.0	6,100	54.1	2,300
20'	54,700	54,000	47,400	40,700	38,000	32,300		75°	38.8	9,200	49.7	4,900	48.6	5,000	68.5	2,200
25'	36,000	34,500	33,700	35,300	31,200	27,800	24,200	70°	50.9	7,000	61.7	4,400	62.9	4,100	81.9	1,900
30'		24,300	23,800	25,000	26,200	23,300	21,000	65°	62.3	5,500	72.5	3,800	76.9	3,500	94.4	1,800
35'		17,800	17,400	18,600	20,000	20,000	18,200	60°	73.2	4,100	82.9	3,300	89.7	2,800	106.0	1,700
40'		13,600	13,100	14,100	15,400	16,200	15,800	55°	83.3	2,500	92.0	2,200	101.0	1,700	116.0	1,200
45'			9,900	11,100	12,100	12,800	13,200	50°	92.7	1,400	100.0	1,100				
50'			7,600	8,500	9,600	10,100	10,700	45°								
55'				6,700	7,700	8,100	8,800	40°								
60'				5,100	6,100	6,400	7,200	35°								
65'				4,000	4,800	5,200	5,900									
70'					3,700	4,100	4,800									
75'						3,000	3,200	3,700								
80'							2,600	3,000								
85'								2,000	2,300							
90'									1,700							
95'																
100'																
104'																
C								0°								27°

A: Boom length in feet  
 B: Load radius in feet  
 C: Minimum boom angle (deg.) for indicated length (no load)  
 R: Load radius in feet

#### Boom length in feet



NOTE: Load radiuses for jib operation are given for reference with the boom fully extended to 110.6' (33.7m).

6,200 lbs. (2,800 kg) shall be subtracted from the rated lifting capacity of main boom, when jib is attached to main boom head.

Jib weight is 2,200 lbs. (1,000 kg).

Standard number of parts of line for outrigger operation should be according to the following table.

Boom Length in Feet (meters)	34.8' (10.6)	34.8' to 47' (10.6 to 14.3)	47.3' to 60' (14.3 to 18.3)	60' to 110.6' (18.3 to 33.7)	Single top Jib
No. of parts of line	10	8	6	4	1

The lifting capacity data stored in the LOAD MOMENT INDICATOR (AML-L) is based on the standard number of parts of line listed in the chart.

# WARNING AND OPERATING INSTRUCTIONS FOR LIFTING CAPACITIES

## GENERAL

1. RATED LIFTING CAPACITIES apply only to the machine as originally manufactured and normally equipped by TADANO LTD. Modifications to the machine or use of optional equipment other than that specified can result in a reduction of capacity.
2. Hydraulic cranes can be hazardous if improperly operated or maintained. Operation and maintenance of this machine must be in compliance with information in the **Operation and Maintenance** manual supplied with the crane. If this manual is missing, order a replacement through the distributor.
3. The operator and other personnel associated with this machine shall fully acquaint themselves with the latest American National Standards Institute (ANSI) safety standards for cranes.

## SET UP

1. Rated lifting capacities on the load chart are the maximum allowable crane capacities. They are based on the machine standing level on a firm supporting surface under ideal job conditions. Depending on the nature of the supporting surface, it may be necessary to have structural supports under the outrigger floats or tires to spread the loads to a larger surface.
2. For outrigger operation, outriggers shall be properly extended with tires free of supporting surface before operating crane.

## OPERATION

1. Rated lifting capacities have been tested to and meet minimum requirements of SAE J1063-Cantilevered Boom Crane Structures Method of Test.
2. Rated lifting capacities do not exceed 85 % of the tipping load on outriggers fully extended as determined by SAE J765-Crane Stability Test Code.  
Rated lifting capacities for partially extended outriggers are determined by this formula, Rated Lifting Capacities = (Tipping Load - 0.1 x Tip Reaction) / 1.25.
3. Rated lifting capacities above bold lines in the chart are based on crane strength and those below, on its stability. They are based on actual load radius increased by boom deflection.
4. The weight of load handling device such as main hook block (950 lbs. for 50 ton capacity), auxiliary hook block (330 lbs. for 6.2 ton capacity), slings, etc., must be considered as part of the load and must be deducted from the lifting capacities.
5. Rated lifting capacities are based on freely suspended loads and make no allowance for such factors as the effect of wind, sudden stopping of loads, supporting surface conditions, inflation of tires, operating speeds, side loads, etc. Side pull on the boom or jib is extremely dangerous.
6. Rated lifting capacities do not account for the effect of wind on a lifted load or boom. Rated lifting capacities and boom length shall be appropriately reduced, when wind velocity exceeds 20 mph (9 m/sec.).
7. Rated lifting capacities at load radius shall not be exceeded. Do not tip the crane to determine allowable loads.
8. Do not operate at boom lengths, radii, or boom angle, where no capacities are shown. Crane may overturn without any load on the hook.
9. When boom length is between values listed, refer to the rated lifting capacities of the next longer and next shorter booms for the same radius. The lesser of the two rated lifting capacities shall be used.
10. When making lifts at a load radius not shown, use the next longer radius to determine allowable capacity.
11. Load per line should not exceed 11,400 lbs. (5,200kg) for main winch and 12,300 lbs. (5,600kg) for auxiliary winch.
12. Check the actual number of parts of line with LOAD MOMENT INDICATOR (AML-L) before operation. Maximum lifting capacity is restricted by the number of parts of line of LOAD MOMENT INDICATOR (AML-L). Limited capacity is as determined from the formula, Single line pull for main winch (11,400 lbs.) x number of parts of line.
13. The boom angle before loading should be greater to account for deflection.
14. The 34.8' (10.6m) boom length capacities are based on boom fully retracted. If not fully retracted [less than 47' (14.3m) boom length], use the rated lifting capacities for the 47' (14.3m) boom length.
15. Extension or retraction of the boom with loads may be attempted within the limits of the RATED LIFTING CAPACITIES. The ability to telescope loads is limited by hydraulic pressure, boom angle, boom length, crane maintenance, etc.
16. For lifting capacity of single top, reduce the rated lifting capacities of relevant boom by the mass of the main hook block. Capacities of single top shall not exceed 12,300 lbs. (5,600 kg) including main hook.
17. When erecting and stowing jib, be sure to retain it by hand or by other means to prevent its free movement.
18. 6,200 lbs. (2,800 kg) shall be subtracted from the rated lifting capacities of the main boom, when jib is attached to main boom head. Jib mass is 2,200 lbs. (1,000 kg).
19. Use Anti-two block (OVERWIND CUTOFF) disable switch when erecting and stowing jib and when stowing hook block. While the switch is pushed, the hoist does not stop, even when overwind condition occurs.
20. For boom length with 32.2' (9.8 m) jib, rated lifting capacities are determined by loaded boom angle only in the column headed 110.6' (33.7m) boom + 32.2' (9.8m) jib. For boom length with 56.1' (17.1m) jib, rated lifting capacities are determined by loaded boom angle only in the column headed 110.6' (33.7m) boom + 56.1' (17.1m) jib. For angles not shown, use the next lower loaded boom angle to determine allowable capacity.
21. When lifting a load by using jib (aux. winch) and boom (main winch) simultaneously, do the following:
  - Enter the operation status as jib operation, not as boom operation.
  - Before starting operation, make sure that mass of load is within rated lifting capacity for jib.

## DEFINITIONS

1. Load Radius: Horizontal distance from a projection of the axis of rotation to supporting surface before loading to the center of the vertical hoist line or tackle with load applied.
2. Loaded Boom Angle: The angle between the boom base section and the horizontal, after lifting the rated lifting capacity at the load radius.
3. Working Area: Area measured in a circular arc about the centerline of rotation.
4. Freely Suspended Load: Load hanging free with no direct external force applied except by the hoist line.
5. Side Load: Horizontal side force applied to the lifted load either on the ground or in the air.





# TR-6005XL-3 RATED LIFTING CAPACITIES (IN POUNDS)

TIRE : 29.5-25-22PR

Load Radius in Feet	ON RUBBER								
	Stationary						Creep		
	Over Front			360° Rotation			Over Front		
	Boom Length in Feet			Boom Length in Feet			Boom Length in Feet		
	34.7' (10.7m)	60.0' (18.3m)	85' (25.9m)	34.7' (10.7m)	60.0' (18.3m)	85' (25.9m)	34.7' (10.6m)	60.0' (18.3m)	85' (25.9m)
10'	55,700			34,200			48,300		
12'	49,600	34,000		33,200	27,000		41,700	30,500	
15'	44,000	34,000	16,500	24,000	23,300		34,100	30,500	14,800
20'	33,200	28,000	16,500	14,800	13,700	15,500	25,700	25,100	14,800
25'	22,900	22,400	16,500	9,400	8,800	10,300	20,100	19,300	14,800
30'		15,800	16,500		5,500	7,000		15,100	14,800
35'		11,600	13,500		3,100	4,600		11,600	13,300
40'		8,700	10,400			3,000		8,700	10,400
45'		6,600	8,100					6,600	8,100
50'		4,800	6,500					4,800	6,500
55'			5,000						5,000
60'			3,900						3,900
65'			3,100						3,100
70'			2,300						2,300
75'			1,700						1,700
A	0°			0°	43°	56°	0°		

A : Minimum boom angle (deg.) for indicated length (no load)

### Boom length in feet

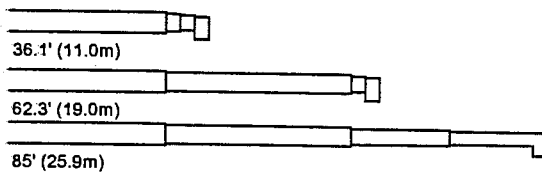

### Working area

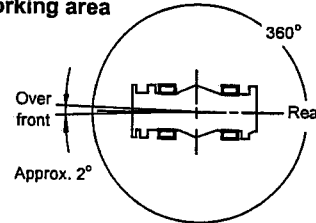

NOTE: Standard number of parts of line for outrigger operation should be according to the following table.

Boom Length in Feet (meters)	34.8' (10.6)	34.8' to 85' (10.6 to 25.9)	Single top
No. of parts of line	6	4	1

The lifting capacity data stored in the LOAD MOMENT INDICATOR (AML-L) is based on the standard number of parts of line listed in the chart.

## WARNING AND OPERATING INSTRUCTIONS FOR ON RUBBER LIFTING CAPACITIES

- Rated lifting capacities on rubber are in pounds and do not exceed 75 % of tipping loads as determined by SAE J765-Crane Stability Test Code.
- Rated lifting capacities shown in the chart are based on condition that crane is set on firm level surfaces with axle oscillation lockout applied. Those above bold lines are based on tire capacity and those below, on crane stability. They are based on actual load radius increased by tire deformation and boom deflection.
- If the axle oscillation lockout cylinders contain air, the axle will not be locked completely and rated lifting capacities may not be obtainable. Bleed the cylinders according to the operation, safety and maintenance manual.
- Rated lifting capacities are based on proper tire inflation, capacity and condition. Damaged tires are hazardous to safe operation of crane.
- Tires shall be inflated to correct air pressure.
- Over front operation shall be performed within two degrees in front of chassis.
- On rubber lifting with "jib" is not permitted. Maximum permissible boom length is 85 ft. (25.9 m).
- When making lift on rubber (stationary), set parking brake.
- For creep operation, boom must be centered over front of machine, swing lock engaged, and load restrained from swinging. Travel slowly and keep the lifted load as close to the ground as possible, and especially avoid any abrupt steering, accelerating or braking.
- Do not operate the crane while carrying the load.
- Creep is motion for crane not to travel more than 200 ft. (60 m) in any 30 minute period and to travel at the speed of less than 1 mph (1.6 km/h).
- For creep operation, set drive select switch to "4-WHEEL (Lo)" and set gear shift lever to "1".

Tires	Air Pressure
29.5-25-22PR	60 psi. (4.2kgf/cm <sup>2</sup> )



## WARNING AND OPERATING INSTRUCTIONS FOR USING THE LOAD MOMENT INDICATOR (AML-L)

- When operating crane on outriggers:
    - Set P.T.O. switch to "ON".
    - Press the outrigger mode select key to register for the outrigger operation. Press the set key, then the outrigger mode indicative symbol changes from flickering to lighting.
    - Press the boom mode select key to register the boom mode, then the boom mode indicative symbol changes from lighting to flickering. Each time the boom mode select key is pressed, the mode changes. Press the set key to select the status that corresponds to the actual state of the boom, then the boom mode indicative symbol changes from flickering to lighting.
    - When erecting and stowing jib, select the status of jib set (jib state indicative symbol flicker).
  - When operating crane on rubber:
    - Set P.T.O. switch to "ON".
    - Press the on-tire mode select key. The on-tire mode indicative symbol comes on. Each time the on-tire mode select key is pressed, the mode changes. Select the creep operation, the on-tire mode indicative symbol flicker.
    - Press the boom mode select key to register the boom mode.
- However, pay attention to the following :
- For stationary operation :
    - The front capacities are attainable only when the over front position symbol comes on. When the boom is more than 2 degrees from centered over front of chassis, 360° capacities are in effect.
  - When a load is lifted in the front position and then swung to the side area, make sure the value of the LOAD MOMENT INDICATOR (AML-L) is below the 360° lifting capacity.
  - For creep operation :
    - The creep capacities are attainable only when boom is in the straight forward position of chassis and the over front position symbol is on. If boom is not in the straight forward position of chassis, never lift load.
  - A swing dose not automatically stop even if the crane becomes overloaded.
  - During crane operation, make sure that the displays on front panel are in accordance with actual operating conditions.
  - The displayed values of LOAD MOMENT INDICATOR (AML-L) are based on freely suspended loads and make no allowance for such factors as the effect of wind, sudden stopping of loads, supporting surface conditions, inflation of tire, operating speed, side loads, etc. For safe operation, it is recommended when extending and lowering boom or swinging, lifting loads shall be appropriately reduced.
  - LOAD MOMENT INDICATOR (AML-L) is intended as an aid to the operator. Under no condition should it be relied upon to replace use of capacity charts and operating instructions. Sole reliance upon LOAD MOMENT INDICATOR (AML-L) aids in place of good operating practice can cause an accident. The operator must exercise caution to assure safety.

TR-6005XL-3 Axle weight distribution chart

	Pounds			Kilograms		
	GVW	Front	Rear	GVW	Front	Rear
Basic standard machine includes: 34.8' ~ 110.6' (10.6 m ~ 33.7 m) 4-section boom 32.2', 56.1' (9.8 m, 17.1 m) 2-stage jib Main hoist with 623' (190 m) of 3/4" (19 mm) diameter wire rope Auxiliary hoist with 361' (110 m) of 3/4" (19 mm) diameter wire rope 50 ton (45.4 metric ton) hook block 6.2 ton (5.6 metric ton) hook ball Auxiliary lifting sheave (single top) Mitsubishi 6D16-TLEA engine 29.5-25-22PR(OR) tires	88,200	45,690	42,510	40,000	20,720	19,280
Remove: 1. 32.2', 56.1' (9.8 m, 17.1 m) 2-stage jib 2. 50 ton (45.4 metric ton) hook block 3. 6.2 ton (5.6 metric ton) hook ball 4. Auxiliary lifting sheave (single top) 5. 29.5-25-22PR (OR) tires	-2,200 -950 -330 -128 -6,990	-3,740 -1,760 +144 -348 -3,495	+1,540 +810 -474 +220 -3,495	-,1000 -431 -150 -58 -3,172	-1,697 -799 +65 -158 -1,586	+697 +368 -215 +100 -1,586

### Bigge Crane and Rigging Co.

10700 Bigge Avenue  
 San Leandro, CA 94577  
 Phone: (888) 337-BIGGE or (510) 638-8100  
 Fax: (510) 639-4053  
 Email: info@bigge.com  
 Web site: www.bigge.com

### TADANO AMERICA CORPORATION

333 NORTHPARK CENTRAL DR, SUITE Z  
 HOUSTON, TEXAS 77073 U.S.A.  
 PHONE: (281)869-0030 EXT.315  
 FAX: (281) 869-0040  
 Web site: www.tadanoamerica.com  
 E-mail: sales@tadano-cranes.com  
 Form No. TAC-TR-6005XL-03-040817