



TR-450XL

45 Ton Capacity (40.8 Metric Tons)

HYDRAULIC ROUGH TERRAIN CRANE

DIMENSIONS

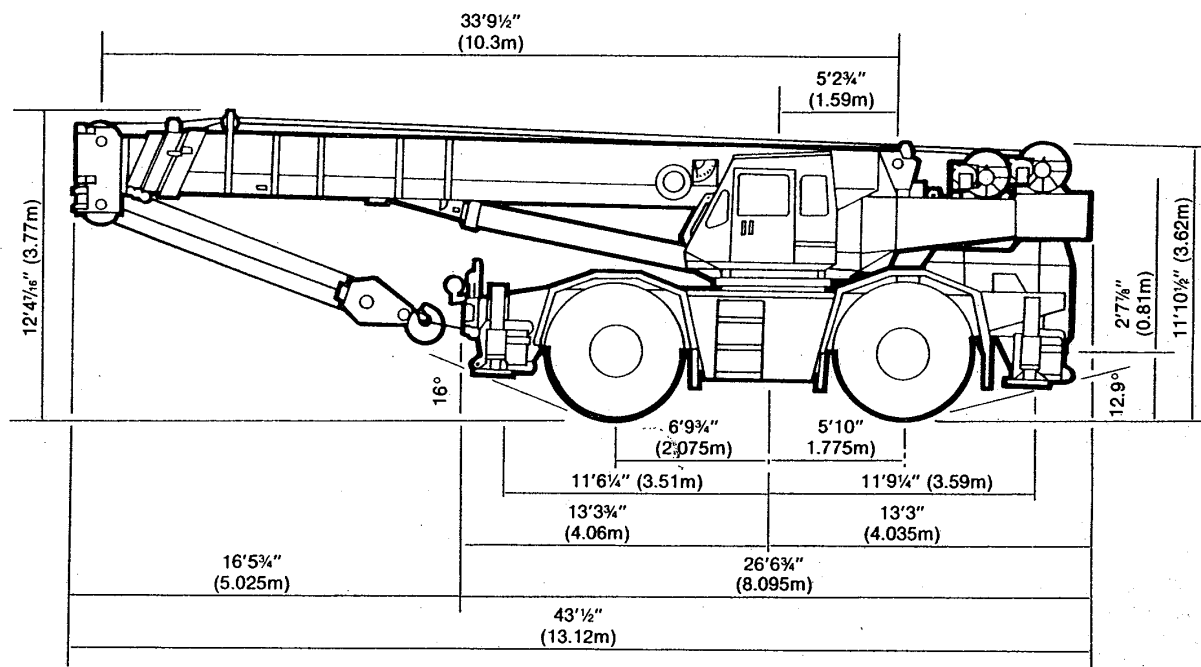

Note: Dimension is with boom angle at -1°.

GENERAL DIMENSIONS (26.5 X 25 Tires)

	Feet	Meters
Turning Radius:		
4 wheel steer	21' 3-7/8"	6.5
2 wheel steer	37' 8-3/4"	11.5
Tail swing of counterweight	13' 1-1/2"	4.0

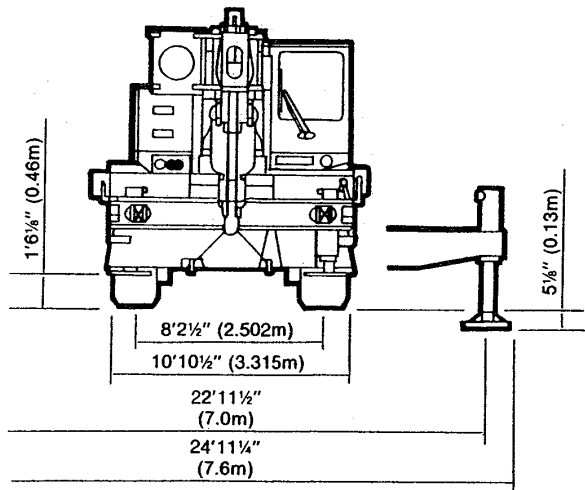



CRANE SPECIFICATIONS



Four section full power synchronized telescoping boom of hexagonal box construction 33.8' ~ 106.6' (10.3 ~ 32.5m) with four sheaves, 17-1/4" (0.438m) root diameter, at boom head. The synchronization system consists of three telescope cylinders fitted with holding valves. Two easily removable wire rope guards, rope dead end provided on right side of boom head. Boom telescope sections are supported by wear pads both vertically and horizontally.

BOOM ELEVATION - Two double acting hydraulic cylinders with holding valve. Elevation -3° ~ 80°, combination controls for hand or foot operation. Boom angle indicator.

JIB - Box top section telescopes from lattice type base section which stores alongside base boom section. 5° or 30° offset (tilt type). Single sheave, 17-1/4" (0.438m) root diameter, at jib head. Jib length is 32.2' (9.8m) or 56.1' (17.1m).

AUXILIARY LIFTING SHEAVE (SINGLE TOP) - Single sheave, 17-1/4" (0.438m) root diameter. Mounted to main boom head for single line work (stowable).

ANTI-TWO BLOCK - Pendant type over-winding cut out device with audio-visual (FAILURE lamp/BUZZER) warning system.

SWING

Hydraulic axial piston motor driven through planetary swing speed reducer. Continuous 360° full circle swing on ball bearing turntable at 2.2 rpm. Equipped with manually locked/released swing brake. A swing lock (pin-in-hole lock) for pick and carry and travel modes, manually engaged in cab.

HOIST

MAIN HOIST - Variable speed type with grooved drum driven by hydraulic axial piston motor through winch speed reducer. Power load lowering and raising. Equipped with automatic brake (Neutral brake) and counterbalance valve. Controlled independently of auxiliary hoist.

DRUM - Grooved 15-3/4" (0.400m) root diameter x 22-3/4" (0.578m) wide. Wire rope: 574' of 3/4" diameter rope (175m of 19mm). Drum Capacity: 905' (276m) 6 layers. Maximum line pull (permissible): 14,272 lbs. (6,474kg)*. Maximum line speed: 525 FPM (160m/min).

AUXILIARY HOIST - Variable speed type with grooved drum driven by hydraulic axial piston motor through winch speed reducer. Power load lowering and raising. Equipped with automatic brake (neutral brake) and counterbalance valve. Controlled independently from main hoist.

DRUM - Grooved 15-3/4" (0.400m) root diameter x 22-3/4" (0.578m) wide. Wire rope: 361' of 3/4" diameter rope (110m of 19mm). Drum Capacity: 905' (276m) 6 layers. Maximum line pull (permissible): 14,272 lbs. (6,474kg)*. Maximum line speed: 525 FPM (160m/min).

Maximum permissible line pull may be affected by wire rope strength.

Wire Rope - Filler wire, extra improved plow steel, pre-formed, independent wire rope core, right regular lay.
3/4" (19mm) 6 x 37 class

HOOK BLOCKS

1. 45 ton (40.8 metric ton) - 4 sheaves with swivel hook and safety latch, for 3/4" (19mm) wire rope.
2. 22 ton (20 metric ton) - 2 sheaves with swivel hook and safety latch, for 3/4" (19mm) wire rope.
3. 5.5 ton (5.0 metric ton) - Weighted hook with swivel and safety latch, for 3/4" (19mm) wire rope.

HYDRAULIC SYSTEM

PUMPS - Two variable piston pumps and one gear pump for crane functions. Tandem gear pump for steering and optional equipment. Powered by carrier engine. Pump disconnect for crane is engaged/disengaged by rotary switch from operator's cab.

CONTROL VALVES - Multiple valves actuated by hand levers with integral pressure relief valves.

RESERVOIR - 195 gallon (740 lit.) capacity. External sight level gauge.

FILTRATION - 26 micron return filter, full flow with bypass protection, located inside of hydraulic reservoir. Accessible for easy replacement.

OIL COOLER - Air cooled fan type.

CAB AND CONTROLS

Both crane and drive operations can be performed from one cab mounted on rotating superstructure.

Left side, 1 man type, steel construction with sliding door access and safety glass windows opening at side and roof. Windshield glass window is shatter-resistant. Adjustable control levers for swing, boom telescoping, boom hoist, auxiliary hoist and main hoist (with swing free-lock selector switch). Engine throttle lever. Foot operated controls: boom hoist, service brake and engine throttle.

Dash-mounted engine start/stop, engine cut off switch, monitor lamps, cigarette lighter, working light switch, and telescoping correction switches.

Instruments - Torque converter oil temperature, engine water temperature, air pressure, fuel, hydraulic oil pressure, torque converter oil pressure, speedometer, tachometer and hour meter.



Tadano electronic LOAD MOMENT INDICATOR system (AML-M) including:

- Control lever lockout function
- Working radius and/or boom angle preset function (warning only)
- Warning buzzer
- Boom angle/boom length/jib offset angle/working radius/rated loads/actual loads read out
- Ratio of actual load moment to rated load moment indication
- Working condition register switch
- External warning lamp

Operator's right hand console includes transmission gear selector, pump engaged/disengaged switch, outrigger controls, sight level bubble, high/low range selector, steering mode select switch, parking brake selector, swing free-lock selector switch, swing lock lever, working light switch and ashtray. Swing brake and 4 way adjustable seat with high back and seat belt.

CARRIER SPECIFICATIONS

TYPE - Rear engine, left hand steering, driving axle 2-way selected type by manual switch, 4 x 2 front drive, 4 x 4 front and rear drive.

FRAME - High tensile steel, all welded mono-box construction.

TRANSMISSION - Torque converter driving full powershift with driving axle selector. 6 forward and 6 reverse speeds.

- 3 speeds - high range - 2 wheel drive
- 3 speeds - low range - 4 wheel drive

TRAVEL SPEED - 21.8 mph maximum.

AXLE - Front: Rigid-mounted, steering and driving axle with planetary reduction. Rear: Pivot-mounted, steering and driving axle with planetary reduction and non-spin differential.

STEERING - Hydraulic power steering controlled by steering wheel. Three steering modes available: 2 wheel front, 4 wheel coordinated and 4 wheel crab.

SUSPENSION - Front: Rigid mounted to frame. Rear: Pivot mounted with hydraulic lockout cylinders.

BRAKE SYSTEMS - Service: Air over hydraulic brakes on all 4 wheels. Parking/Emergency: Spring applied—air released brake acting on input shaft of front axle.

TIRES - Standard 26.5 x 25 - 24PR (OR)

OUTRIGGERS - Four hydraulic, beam and jack outriggers. Vertical jack cylinders equipped with integral holding valve. Each outrigger beam and jack is controlled independently from cab. Beams extend to 22' 11-1/2" (7.0m) center-line and retract to within 10' 10-1/2" (3.315m) overall width with floats. Outrigger jack floats are attached thus eliminating the need of manually attaching and detaching them. Controls and sight bubble located in upper structure cab.

ENGINE

Model	Mitsubishi 6D22
Type	Direct Injection Diesel
No. of cylinders	6
Combustion	4 cycle, naturally aspirated
Bore x Stroke, in. (mm)	5.118 x 5.512 (130 x 140)
Displacement, cu. in (liters)	680 (11.149)
Air inlet heater	24 volt preheat
Air cleaner	Dry type, replacement element
Oil filter	Full flow with replacement element
Fuel Filter	Full flow with replacement element
Fuel tank, gal. (liters)	79.2 (300), right side of carrier
Cooling	Liquid pressurized, recirculating by-pass

Radiator	Fin and tube core, thermostat controlled
Fan, in. (mm)	Blower type, 6-blade, 25.6 (650) dia.
Starting	24 volt
Charging	24 volt system, negative ground
Battery	2 - 140 amp. hour
Compressor, air, CFM (l/min)	14.9 CFM (420 LPM) at 2,000 rpm
Horsepower (KW)	Net 180 (134) at 2,300 rpm Gross 190 (139) at 2,300 rpm
Torque, Max. ft-lb (kgm)	463 (64) at 1,400 rpm
Capacity, gal. (liters)	
Cooling water	5.8 (22)
Lubrication	6.3 ~ 7.7 (24 ~ 29)
Fuel	79.2 (300)



STANDARD EQUIPMENT

- section full power synchronized boom 33.8' ~ 106.6' (10.3m ~ 32.5m)
- Two stage stowable telescoping jib 32.2' (9.8m) or 56.1' (17.1m) with 5° or 30° pinned offset (tilt type)
- Auxiliary lifting sheave (single top) stowable
- Boom hoist foot control
- Boom angle indicator
- Variable speed main hoist with cable follower
- Variable speed auxiliary hoist with cable follower
- Tadano twin swing system
- 4 x 4 x 4 drive
- Hydraulic lockout system rear axle
- Independently controlled outriggers
- Self-storing outrigger pads
- Full powershift transmission driven by torque converter
- Complete highway light package
- Anti two block device (Overwind cutout)
- Electronic crane monitoring system
- Tadano electronic load moment indicator system (AML-M) including:
 - Control lever lockout function
 - Working radius and/or boom angle preset function (warning only)
 - Warning buzzer
 - Boom angle/boom length/jib offset angle/working radius/ rated loads/actual loads read out
 - Ratio of actual load moment to rated load moment indication
 - Working condition register switch
- External warning lamp
- Front windshield wiper and washer
- Roof windshield wiper
- Rear view mirrors (right and left side)
- 4 way adjustable seat with high back

- Seat belt
- Cab floor mat
- Electric fan in cab
- Back up alarm
- Low oil pressure/high water temperature warning device (visual)
- Rear steer centering light
- Fenders
- Air cleaner dust indicator
- Towing hooks - front and rear
- Lifting eyes
- Tool storage compartment
- Full instrumentation package
- Pump disconnect in operator's cab
- Air dryer
- Non-spin rear differential
- Water separator with filter
- Flood lights
- Outrigger hose protection
- 24 volt electric system
- 24 volt start
- Hydraulic oil cooler
- 45 ton (40.8 metric ton) 4 sheave hook block
- 5.5 ton (5.0 metric ton) hook ball and swivel

OPTIONAL EQUIPMENT

- 22 ton (20 metric ton) 2 sheave hook block
- Propane heater
- Fire extinguisher
- Tool kit
- Drum rotation indicator (thumper type) main and/or aux hoist

HOISTING SPECIFICATIONS

LINE SPEEDS AND PULLS

Layer	Speed	Main or auxiliary hoist - 15-3/4" (0.4m) drum					
		Line Speeds ¹		Line pulls			
		PPM	Min/min	Available ⁴		Permissible ⁴	
				Lbs	kgf	Lbs	kgf
1st	Low	180	55	15,698	7,121	14,272	6,474
	High	361	110				
2nd	Low	97	60	14,647	6,644	13,315	6,040
	High	394	120				
3rd	Low	713	85	13,520	6,133	12,292	5,576
	High	427	100				
4th	Low	230	70	12,557	5,696	11,417	5,173
	High	460	140				
5th	Low	216	75	11,721	5,317	10,657	4,834
	High	432	150				
6 th	Low	262	80	10,989	4,985	9,991	4,532
	High	525	160				

¹Developed by machinery with first layer of wire rope, but not based on rope strength or other limitation in machinery or equipment.
²Line speeds based only on hook block, not loaded.
³Sixth layer of wire rope is not recommended for hoisting operations.
⁴Permissible line pull may be affected by wire rope strength.

DRUM WIRE ROPE CAPACITIES

Wire Rope Layer	Main and auxiliary drum grooved lagging			
	3/4" (19mm) wire rope			
	Rope per layer		Total wire rope	
	Feet	Meters	Feet	Meters
1	123.0	37.5	123.0	37.5
2	134.2	40.9	257.2	78.4
3	145.3	44.3	402.5	122.7
4	156.5	47.7	559.0	170.4
5	167.7	51.1	726.7	221.5
6	178.8	54.5	905.5	276.0

DRUM DIMENSIONS

	Inch	mm
Root Diameter	15-3/4"	400
Length	22-3/4"	578
Flange Diameter	25-3/8"	645



TR-450XL OPERATING RADIUS/LIFTING HEIGHT CHART

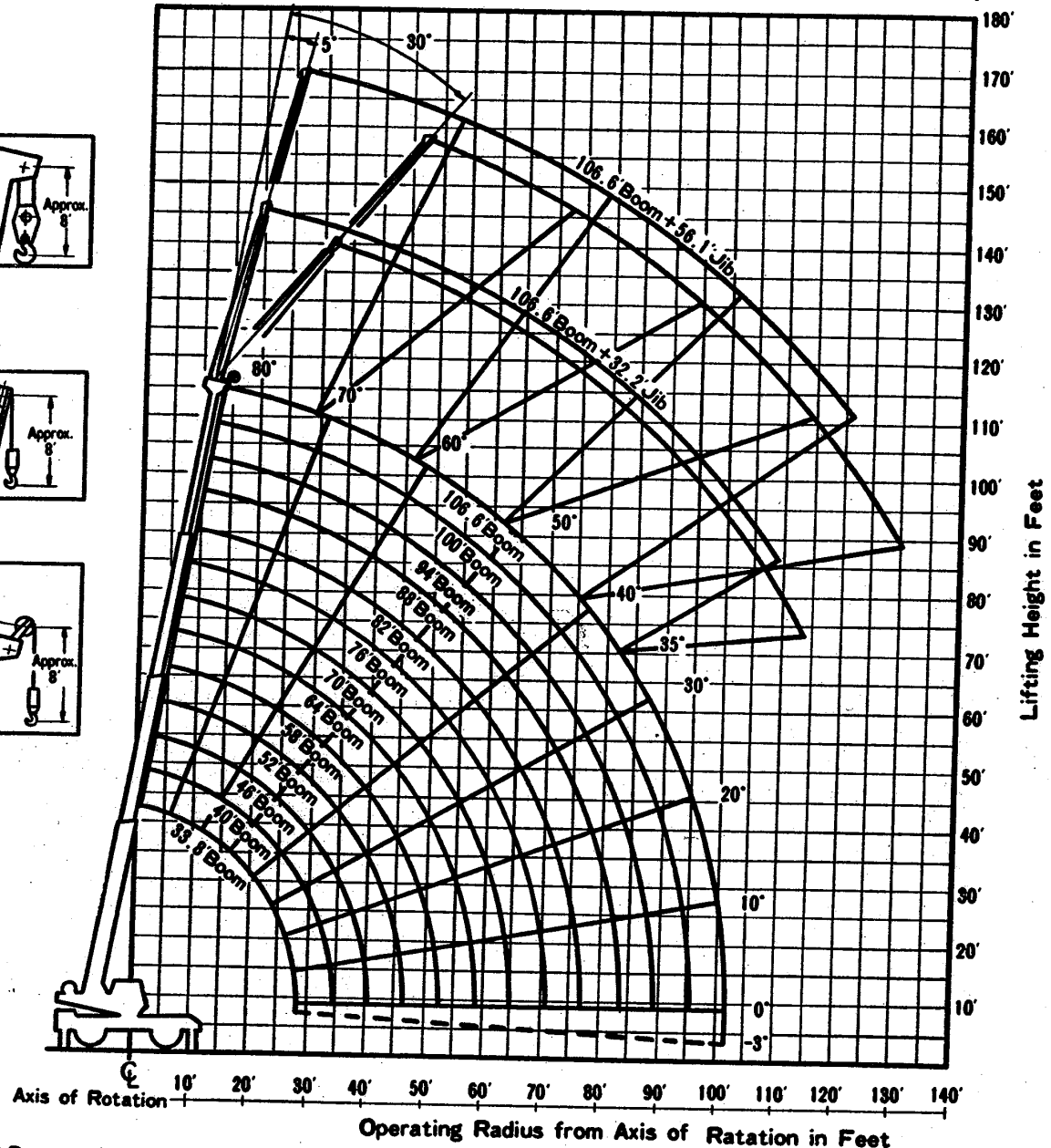
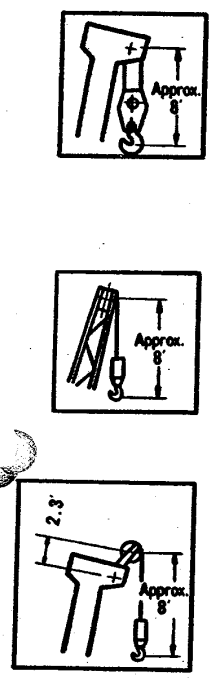

NOTE: Boom and jib geometry shown are for unloaded condition and machine standing level on firm supporting surface. Boom deflection and subsequent radius and boom angle change must be accounted for when applying load to hook.



IR-450XL TOTAL RATED LOAD CHART (IN POUNDS)

ON OUTRIGGERS FULLY EXTENDED 360° ROTATION

Load Radius in Feet	Boom Length in Feet												
	33.8 (10.3m)	40 (12.2m)	46 (14.0m)	52 (15.8m)	58 (17.7m)	64 (19.5m)	70 (21.3m)	76 (23.2m)	82 (25.0m)	88 (26.8m)	94 (28.7m)	100 (30.5m)	106.6 (32.5m)
10	90,000 (64')	81,200 (69')	77,100 (72')	68,000 (74')	67,400 (76')								
12	79,300 (60')	78,000 (66')	76,500 (69')	64,700 (72')	62,300 (74')	55,600 (76')	47,300 (77')						
15	65,400 (55')	65,400 (61')	65,600 (65')	59,700 (68')	55,700 (71')	49,800 (73')	44,200 (75')	40,300 (76')	37,400 (77')				
20	48,500 (43')	48,500 (52')	48,600 (58')	48,000 (62')	47,400 (65')	42,000 (68')	37,000 (70')	33,500 (72')	32,000 (73')	31,000 (75')	30,400 (76')	28,600 (77')	
25	37,400 (27')	37,600 (42')	37,900 (50')	38,100 (55')	38,300 (60')	35,300 (63')	31,900 (64')	28,300 (68')	26,500 (70')	25,900 (72')	25,400 (73')	24,900 (75')	23,900 (76')
30		29,800 (29')	30,000 (41')	30,200 (48')	30,500 (54')	29,500 (58')	28,000 (61')	24,400 (64')	22,800 (66')	22,000 (68')	21,600 (70')	21,100 (71')	19,900 (73')
35		23,800 (3')	24,400 (30')	24,700 (40')	24,900 (47')	24,800 (52')	24,900 (56')	21,600 (59')	19,600 (62')	19,000 (64')	18,500 (67')	18,100 (68')	17,200 (70')
40			20,400 (10')	20,600 (30')	20,800 (40')	20,800 (46')	20,800 (51')	18,700 (55')	17,300 (58')	16,400 (61')	16,000 (63')	15,700 (65')	14,800 (67')
45				17,300 (15')	17,400 (31')	17,400 (39')	17,400 (45')	15,800 (50')	15,200 (54')	14,700 (57')	14,300 (59')	13,800 (62')	13,000 (64')
50					14,100 (18')	14,100 (31')	14,100 (39')	13,500 (45')	13,600 (49')	13,100 (53')	12,700 (56')	12,300 (59')	11,400 (61')
55						11,900 (20')	11,900 (32')	12,000 (39')	12,300 (44')	11,800 (49')	11,300 (52')	10,900 (55')	10,000 (58')
60							9,900 (22')	10,100 (32')	10,100 (39')	10,400 (44')	10,200 (48')	9,800 (51')	9,000 (54')
65								8,200 (23')	8,400 (32')	8,600 (39')	8,900 (45')	8,800 (47')	7,900 (51')
70									6,200 (5')	6,800 (25')	7,100 (33')	7,500 (39')	7,100 (47')
75										6,200 (3')	6,300 (25')	6,200 (39')	6,200 (43')
80											5,000 (16')	5,000 (27')	5,200 (39')
85												4,600 (18')	4,600 (34')
90													3,900 (19')
95													3,300 (3')
100													2,600 (12')

Boom Length in Feet

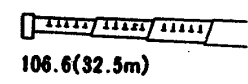
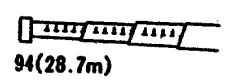
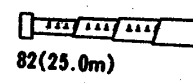
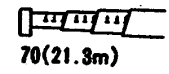
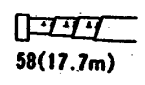

NOTE:
6,200 lbs. (2,800 kgs) shall be subtracted from the total rated loads of main boom, when jib is attached to main boom head. Jib weight is 2,200 lbs. (1,000 kgs).

ON OUTRIGGERS FULLY EXTENDED 360° ROTATION

Boom Angle in Degree	Boom Length in Feet			
	106.6 (32.5m) Boom + 22 (6.7m) Jib		106.6 (32.5m) Boom + 58 (17.7m) Jib	
	5' Tit	30' Tit	5' Tit	30' Tit
80°	11,000	3,500	6,100	2,300
75°	9,200	4,900	5,000	2,200
70°	7,000	4,400	4,100	1,900
65°	5,300	3,800	3,500	1,800
60°	4,500	3,300	2,800	1,700
55°	3,700	2,800	2,300	1,600
50°	3,200	2,600	1,900	1,400
45°	2,500	2,300	1,600	1,300
40°	1,600	1,500	1,200	1,200

NOTE: Boom Angles are in degrees. Standard number of parts of line should be according to the following table.

Boom Length in Feet (meters)	33.8 to 46 (10.3 to 14.0)	46 to 64 (14.0 to 19.5)	64 to 106.6 (19.5 to 32.5)	Single top Jib
No. of part line	8	6	4	1

The lifting capacity data stored in the LOAD MOMENT INDICATOR (ALM-M) is based on the standard number of parts of line listed in the chart.

SET UP

- Total rated loads shown on the chart are the maximum allowable crane capacities and are based on the machine standing level on firm supporting surface under ideal job conditions. Depending on the nature of the supporting surface, it may be necessary to have structural supports under the outrigger floats or tires to spread the load to a larger bearing surface.
- For outrigger operation, outriggers shall be fully extended with tires free of supporting surface before operating crane.

OPERATION

- Total rated loads with outriggers fully extended do not exceed 85% of the tipping loads as determined by SAE Crane Stability Test Code J-765.
- Total rated loads above bold lines in the chart are based on crane strength and those below, on its stability. They are based on actual load radius increased by boom deflection.
- Total rated loads include the weight of main hook block (1,000 lbs. for 45 ton capacity optional secondary hook block (580 lbs. for 22 ton capacity) auxiliary hook ball lbs. for 6.2 tons capacity), sling and auxiliary lifting devices and their weights shall be subtracted from the listed capacities to obtain the net load to be lifted.
- Total rated loads are based on freely suspended loads and make no allowance for such factors as the effect of wind, sudden stopping of loads, supporting surface conditions, inflation of tires, operating speeds, side loads, etc. Side pull on boom or jib is extremely dangerous.

WARNING AND OPERATING INSTRUCTIONS FOR LIFTING CAPACITIES

GENERAL

- Total rated loads shown on the TOTAL RATED LOAD CHART apply only to the machine as originally manufactured and normally equipped by TADANO LTD. Modifications to the machine or use of optional equipment other than that specified can result in a reduction of capacity.
- Construction equipment can be dangerous if improperly operated or maintained. Operation and maintenance of this machine must be in compliance with the information in the operation, safety and maintenance manual supplied with machine. If this manual is missing, order replacement through the distributor.
- The operator and other personnel associated with this machine shall fully acquaint themselves with the latest applicable American National Standards Institute (ANSI) safety standards for cranes.



- Total rated loads do not account for wind on lifted load or boom. Total rated loads and boom length shall be appropriately reduced, when wind velocity is above 20 mph (9m/sec.).
- Total rated loads at load radius shall not be exceeded. Do not tip the crane to determine allowable loads.
Do not operate at boom lengths, radii, or boom angle, where no capacities are shown. Crane may overturn without any load on the hook.
When boom length is between values listed, refer to the total rated loads of the next longer and next shorter booms for the same radius. The lesser of the two total rated loads shall be used.
- When making lifts at a load radius not shown, use the next longer radius to determine allowable capacity.
- Load per line should not exceed 11,850 lbs. (5,400 kg) for main winch and 11,000 lbs. (5,000 kg) for auxiliary winch.
- Loaded boom angles are approximate. The boom angle before loading should be greater to account for deflection.
- When making lift on outriggers, telescoping boom sections must be extended equally at all times. If 2nd, 3rd, and top sections do not telescope evenly, equalize their extension by using "TELESCOPING CORRECTION" switches before lifting loads.
- The 33.8' (10.3m) boom length capacities are based on boom fully retracted. If not fully retracted [less than 40.0' (12.2m) boom length], use the total rated loads for the 40.0' (12.2m) boom length.
- Extension or retraction of the boom with loads may be attempted within the limits of the TOTAL RATED LOAD CHART. The ability to telescope loads is limited by hydraulic pressure, boom angle, boom length, crane maintenance, etc.
- For lifting capacity of single top, reduce the total rated loads of relevant boom by 1,000 lbs. (450 kg). Capacities of single top shall not exceed 11,000 lbs. (5,000 kg) including main hook.
- When erecting and stowing jib, be sure to retain it by hand or by other means to prevent its free movement.
- 6,200 lbs. (2,800 kg) shall be subtracted from the total rated loads of the main boom, when jib is attached to main boom head. Jib weight is 2,200 lbs. (1,000 kg).
- Use Anti-Two Block (OVERWIND CUTOFF) disable switch when erecting and stowing the jib and stowing the hook block. While the switch is pushed, the hoist does not stop, even when overwind condition occurs.

- Stop swing operation immediately when SWING warning lamp lights and warning buzzer sounds. These warnings are emitted when boom enters area A (diagram 1) with boom angle below 9°. This action prevents collision between boom elevating cylinders and engine hood.
- For boom lengths with 32.2' (9.8m) jib, the total rated loads are determined by loaded boom angle only in the column headed 106.6' (32.5m) boom + 32.2' (9.8m) jib. For boom lengths with 56.1' (17.1m) jib, the total rated loads are determined by loaded boom angle only in the column headed 106.6' (32.5m) boom + 56.1' (17.1m) jib. For angles not shown, use the next lower loaded boom angle to determine allowable capacity.
- When lifting a load by using jib (aux. winch) and boom (main winch) simultaneously, do the following:
 - Illuminate the jib indicator lamps and make the jib offset display screen indicate the same value as the actual offset by pushing the boom state register switch repeatedly.
 - Before starting operation, make sure that weight of load is within total rated load for jib.

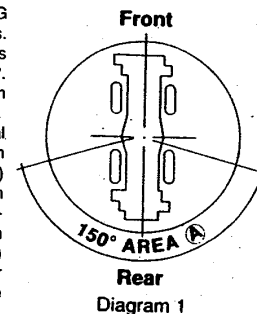

DEFINITIONS

- Load Radius:** Horizontal distance from a projection of the axis of rotation to supporting surface before loading to the center of the vertical hoist line or tackle with load applied.
- Loaded Boom Angle:** The angle between the boom base section and the horizontal, after lifting the total rated load at the load radius.
- Working Area:** Area measured in a circular arc about the centerline of rotation.
- Freely Suspended Load:** Load hanging free with no direct external force applied except by the hoist line.
- Side Load:** Horizontal side force applied to the lifted load either on the ground or in the air.

TR-450XL TOTAL RATED LOAD CHART (IN POUNDS)

ON RUBBER TIRE : 26.50-25-24PR

Load Radius in Feet	Stationary		Creep
	Over Front	360° Rotation	Over Front
10	55,100 (a)	34,100 (a)	50,200 (a)
12	49,300 (a)	31,300 (a)	45,300 (a)
15	43,400 (a)	22,800 (a)	38,100 (a)
20	32,700 (a)	14,400 (c)	28,100 (a)
25	22,100 (b)	9,300 (e)	19,800 (b)
30	16,800 (d)	6,300 (e)	16,200 (b)
35	13,300 (e)	4,500 (e)	13,100 (d)
40	10,500 (e)	3,300 (e)	10,500 (e)
45	9,200 (e)	2,600 (e)	9,200 (e)
50	8,900 (e)	1,700 (e)	6,900 (e)
55	5,700 (e)		5,700 (e)
60	4,800 (e)		4,800 (e)
65	3,800 (e)		3,800 (e)
70	3,300 (e)		3,300 (e)
75	2,800 (e)		2,800 (e)

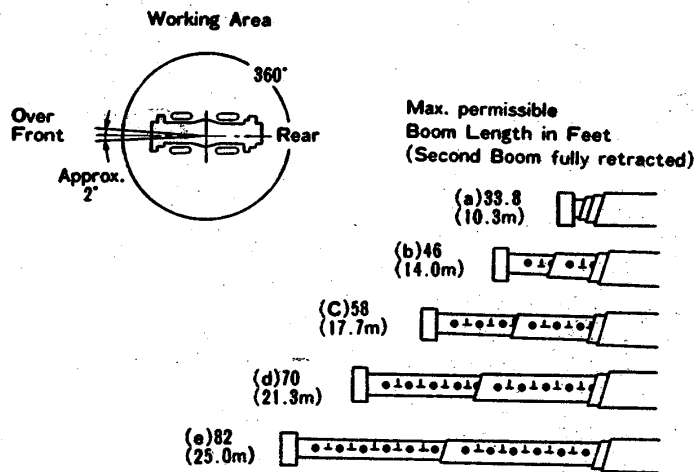

NOTE: The lifting capacity data stored in the LOAD MOMENT INDICATOR (ALM-M) is based on the standard number of parts of line listed in the chart.

WARNING AND OPERATING INSTRUCTIONS FOR ON RUBBER CAPACITIES

- Total rated loads on rubber are in pounds and do not exceed 75% of tipping loads as determined by test in accordance with SAE J-765.
- Total rated loads shown in the chart are based on condition that crane is set on firm level surfaces with axle oscillation lockout applied. Those above bold lines are based on tire capacity and those below, on crane stability. They are based on actual load radius increased by tire deformation and boom deflection.
The axle oscillation lockout cylinders contain air, the axle will not be locked completely and total rated loads may not be obtainable. Bleed the cylinders according to the operation, safety and maintenance manual.
- Total rated loads are based on proper tire inflation, capacity and condition. Damaged tires are hazardous to safe operation of crane.
- Tires shall be inflated to correct air pressure.
- Over front operation shall be performed within two degrees in front of chassis.
- When making lift on rubber, 2nd boom section must be fully retracted. 3rd and top boom section must be extended equally. If not, equalize their travels by using "TELESCOPING CORRECTION" switches, before lifting the loads.
- On rubber lifting with "jib" and with "single top" are not permitted. Maximum permissible boom length is 82 ft. (25.0m).
- When making lift on rubber, set parking brake.
- For creep operation, boom must be centered over front of machine, swing lock engaged, and load restrained from swinging. Travel slowly and keep the lifted load as close to the ground as possible, and especially avoid any abrupt steering, accelerating or braking.
- Do not operate the crane while carrying the load.
- Creep is motion for crane not to travel more than 200 ft. (60 m) in any 30 minute period and to travel at the speed of less than 1 mph (1.6 km/h).

TIRE AIR PRESSURE
26.50-25-24PR—75 psi (5.25 kgf/cm²)



WARNING AND OPERATING INSTRUCTIONS FOR USING THE LOAD MOMENT INDICATOR (AML-M)

Notes for Load Moment Indicator

- operating crane on rubber:
 - P.T.O. switch to "ON".
 - Push the outrigger state register switch to illuminate the outrigger indicator lamps.
 - Push the boom state register switch repeatedly until the state of the indicator lamps and the offset display screen conforms to the actual state of the boom, the single top and the jib.
 - When erecting and stowing jib, push boom state register switch repeatedly until jib indicator lamps flicker (in jib erection/stowing mode).
- When operating crane on rubber:
 - Set P.T.O. switch to "ON".
 - Push the boom state register switch repeatedly to illuminate the boom indicator lamp.
 - Push the on rubber state register switch to illuminate the on rubber indicator lamps. By repeatedly pushing the on rubber register switch, stationary and creep operation are selected alternately. When creep operation is selected, the on rubber indicator lamps flicker.

However, pay attention to the following:

- For stationary operation:
 - The front capacities are attainable only when the over front indicator lamp is on. When the boom is more than 2 degrees from centered over front of chassis, 360° capacities are in effect.

- When a load is lifted in the front position and then swung to the side area, make sure the value of the LOAD MOMENT INDICATOR (AML-M) is below the 360° lifting capacity.
- For creep operation:
 - The creep capacities are attainable only when boom is in the straight forward position of chassis and the over front indicator is on. If boom is not in the straight forward position of chassis, never lift load.
 - During crane operation, make sure that the displays on front panel are in accordance with actual operating conditions.
 - The displayed values of LOAD MOMENT INDICATOR (AML-M) are based on freely suspended loads and make no allowance for such factors as the effect of wind, sudden stopping of loads, supporting surface conditions, inflation of tire, operating speed, side loads, etc. For safe operation, it is recommended when extending and lowering boom or swinging, lifting loads shall be appropriately reduced.
 - LOAD MOMENT INDICATOR (AML-M) is intended as an aid to the operator. Under no condition should it be relied upon to replace use of capacity charts and operating instructions. Sole reliance upon LOAD MOMENT INDICATOR (AML-M) aids in place of good operating practice can cause an accident. The operator must exercise caution to assure safety.

TR-450XL Axle Weight Distribution Chart

	Pounds			Kilograms		
	GVW	Front	Rear	GVW	Front	Rear
Basic standard machine includes: 33.8' ~ 106.6' (10.3 ~ 32.5m) 4-section boom 32.2' ~ 56.1' (9.8 ~ 17.1m) 2-stage jib Main hoist with 574 ft. (175m) of 3/4" (19mm) diameter wire rope Aux hoist with 361' (110m) of 3/4" (19mm) diameter wire rope 45 ton (40.8 metric ton) hook block 5.5 ton (5.0 metric ton) hook ball Mitsubishi 6D22 engine; 26.5 X 25 - 24PR tires	86,770	44,757	42,013	39,359	20,302	19,057
Remove: 1. 32.2' ~ 56.1' (9.8m ~ 17.1m) 2-stage jib 2. 45-ton (40.8 metric ton) hook block 3. 5.5-ton (5.0 metric ton) hook ball 4. Auxiliary lifting sheave	- 2,200 - 1,000 - 330 - 132	- 3,260 - 1,776 + 112 - 361	+ 1,060 + -776 - 442 + 229	- 1,000 - 455 - 150 - 60	- 1,480 - 807 + 51 - 164	+ 480 + 352 - 201 + 104

BIGGE
EQUIPMENT CO.



P.O. BOX 1657 • 10700 BIGGE AVENUE
SAN LEANDRO, CALIFORNIA 94577