



5500

product guide

features

- 2 models ...
 - 5540F: 15.0T (13.6mt) 3-section boom with 41 ft. 0 in. (12.5m) outreach
 - 5560B: 18.0T (16.3mt) 4-section boom with 54 ft. 6 in. (16.6m) outreach
- 15 ft. (4.6m) offsettable swingaway extension
- 20,000 lb. (9 072kg) deck carrying capacity
- 101 bhp (75.3 kW) GM EFI dual fuel engine or 99 bhp (73.8 kW) Cummins, Tier III, diesel engine



contents

Features	2
Specifications	3
5540F	
Dimensions	5
Working Range	6
Load Chart	8
Load Chart	9
5560B	
Dimensions	10
Range Diagram	11
Load Chart	12

Manitowoc
www.manitowoc.com

Industrial Hydraulic Crane

features

2



- Single position oblique style outriggers (5540F).
- 2-position beam / jack style outriggers (5560B).



- Standard:** Open air cab shell w/overhead safety glass
- Optional:** Closed cab with hinged door, heater, and defroster



- Standard:**
 - Cummins QSB 3.3L, Tier III, diesel rated @ 99 bhp (73.8Kw) @ 2600 r.p.m.



- Standard:** 41 ft. (12.5m) main boom on the 5540F
54 ft. 6 in. (16.6m) main boom on the 5560B
- Optional:** 5540F: Manual 4th main boom section adds 11 ft. (3.4m) additional main boom length



- Standard:** 2-wheel, 4-wheel and crab steer (5540F)
- Optional:** 2-wheel, -4-wheel, and crab steer with electronic self-alignment (std. on 5560B)

5500



specifications

3

Superstructure

Boom

5540F: 18 ft. 6 in. – 41 ft. 0 in. (5.6m – 12.5m) three-section full power boom.

Maximum tip height: 46 ft. 3 in. (14.1m)

5560B: 18 ft. 6 in. – 54 ft. 6 in. (5.6m – 16.6m) four-section full power boom.

Maximum tip height: 62 ft. 6 in. (19.0m)

*Optional Boom

5540F: Manual 4th main boom fly section

Maximum tip height: 56 ft. 3 in. (17.0m)

*Boom Extension

15 ft. (4.6m) offsettable swingaway extension

Boom Nose

5540F: 2 sheave non-pivoting boom nose

5560B: Two sheave, -3-position (0°, +40°, +80°) pivoting boom nose for minimizing head space requirements. Lowers head height 15.9 in. (0.4m) when nose is pivoted fully forward.

Boom Elevation

5540F: Single double acting hydraulic cylinder with integral holding valve.

5560B: Two double acting hydraulic cylinders with integral holding valve.

Elevation: 0° to 69° for the 5540F

0° to 80° for the 5560B

Anti-Two Block Device

Standard anti-two block device, when activated, provides an audible warning to the crane operator and disengages all crane functions whose movement can cause two-blocking.

Load Indicator (wireless LSI)

A simple effective and easy to use load indicating system used in conjunction with the anti-two block system to assist the operator in efficient operation of the unit within the limits of the load chart. The display panel displays the hook load and warns the operator when a preset load capacity is exceeded. The warning is by a flashing light on the display panel. In conjunction with the load display panel (receiver), there is a wireless transmitter and load sensing pin attached to the boom head that transmits the hook load to the display panel.

*Rated Capacity Limiter (wireless RCL)

Similar to the Load Indicator, but stops the telescope out and boom lift down function when a load limit is exceeded. Uses a similar display panel with the addition of displaying boom angle and boom length read outs on the panel.

*Load Moment Indicator (hardwired LMI)

Digital display of boom angle, boom length, boom radius, capacity, and allows for operator input to set the limits based on load chart. Displays color coded light bar and audible alarm with function cutout if load exceeds entered parameters.

Swing

Ball bearing swing circle with 360° continuous rotation. Hydraulic driven worm gear and pinion.

Maximum speed: 5540F: 2.1 rpm

5560B: 2.5 rpm

Hydraulic System

4 section gear pump providing a system pressure of 3500 psi (241.3 bars)

Combined flow: 88.0 gpm (333.1 Lpm)

5540F: Six section valve bank mounted in dash with direct mechanical linkage for low effort lever control.

5560B: Six section valve bank chassis mounted; operated via dash mounted, pilot pressure hydraulic joysticks.

Return line filter with full flow by-pass protection and service indicator.

40 gallon (151.4 L) hydraulic reservoir with sight level gauge and steel side plating to guard against side impact damage.

Hoist Specifications

Piston motor drive with spring applied / hyd. released brake. Equal speed power up and down.

Drum Diameter: 9.75 in. (0.25m)

Maximum hoist single line pull: 12,000 lb. (5 443kg)

Maximum hoist single line speed:

5540F: 126 FPM (38.4m / min)

5560B: 158 FPM (48.2m / min)

Maximum Permissible Single Line Pull:

5540F: 7,500 lb (3 402kg)

(1/2" [12.7mm] EEIPS)

5560B: 9,000 lb (4 082kg)

(1/2" [12.7mm] Python Ultra)

Rope Length:

5540F:

(3-section boom) 240 ft. (73.0m)

(4-section boom) 290 ft. (88.4m)

5560B:

310 ft. (94.5m)

*Denotes optional equipment

5500 Series

specifications

5500 Series

4

Carrier

Frame

High strength alloy steel constructed with integral outrigger housings; front and rear tie-down lugs. 75 ft.² carrydeck size with 20,000 lb (9 072kg) carrying capacity. Deck coated with anti-skid treatment.

Outriggers

5540F: Front and rear oblique type beams at all four corners with integral holding valves. Outrigger pads form an integral part of the beam. Outrigger pad size 8.75" x 10" (222 mm x 254 mm).

5560B: 2-stage hydraulic telescoping beam with oblique type jack on all four corners, provides extended and down and retracted and down lifting capacities. Integral holding valves on both beam and jack. Outrigger pad size 8.75" x 10" (222 mm x 254 mm).

Outrigger Controls

5540F: Lever controls located on dash panel and operate the beams in pairs from side to side. Level bubble located inside operators compartment.

5560B: Two switch operation mounted on dash panel. One 3-position rocker switch to select all beams / jacks, left beams / jacks only, or right beams / jacks only. Separate 4-way toggle switch to activate beams out / in and jacks down / up. Level bubble indicator located inside operators compartment.

*Independent outrigger controls available as an option.

Std. Engine

Cummins QSB 3.3L turbo-charged diesel rated @ 99 bhp (73.8kW) @ 2600 rpm.

*Optional Engine

G.M. 4.3L V-6 EFI dual fuel (gasoline / L.P.) rated @ 101 bhp (75.3kW) @ 2500 rpm.

Operators Control Station

Frame mounted, open air style control station with cab shell includes all crane functions, driving controls, and overhead safety glass. Other standard equipment include a durable weather resistant seat with seat belt, hourmeter, sight level bubble, and fire extinguisher. The dash panel includes engine oil pressure gauge, engine water temperature gauge, fuel gauge, transmission low oil and high temperature warning lights, low battery warning light, and brake system low pressure warning light. The LSI (load indicator) receiver is mounted to the top of the dash.

*Operators Control Station Enclosed

Includes the standard cab shell with the addition of front, right, and rear glass. Hinged full door with sliding glass.

Front windshield wiper, heater and defroster are included.

Fuel Tank Capacity

40 gallon (151.4 L) all steel construction with steel side plate to guard against side impact.

Electrical System

One 12V maintenance free battery, 820CCA @ 0°. 63 amp alternator.

Drive

4 x 2 – Front axle drive with planetary hubs and limited slip differential.

Steer

5540F: 2-wheel, 4-wheel, and crab steer

5560B: 2-wheel, -4-wheel, and crab steer w/electric self alignment.

Transmission

5540F: I.T.L. synchromesh 4-speeds forward and reverse.

5560B: I.T.L. powershift 4-speeds forward and reverse. Stalk mounted shifter on left side of steering column.

Tires

385/65R 22.5 radial traction tread pneumatic.

Brakes

Hydraulic actuated internal wet-disc service brakes acting on all four wheels. A dash mounted toggle switch activates the dry disc parking brake on the transmission output yoke with a dash warning light.

Suspension

Front & Rear: Rigid mounted to frame.

Option: Provides 1.5° oscillation for use on semi-rough terrain. Axle lock-out must be engaged (locked) whenever picking on rubber or traveling in the crab steer mode. A warning light indicates when the axle lock-outs are engaged.

*Optional 4° oscillation.

Lights

Recessed mounted, includes head, tail, rear work, stop, and turn signals.

Maximum Speed

5540F: 14.5 mph (23.3km/h)

5560B: 21.0 mph (33.8km/h)

Gradeability**

5540F: 73%....no load

41%....20,000lb (9 072kg) load

5560B: 68%....no load

40%....20,000lb (9 072kg) load

G.V.W.

5540F: 26,300 lb (11 930kg) 3-section boom

26,750 lb (12 134kg) 4-section boom

5560B: 30,000 lb (13 608kg)

Miscellaneous Standard Equipment

Two sheave, "Quick Reeve" style hookblock;

5540F: 15.0T (13.6mt); 5560B: 18.0T (16.3mt).

Back-up alarm

Lifting and tie down lugs

*Denotes Optional Equipment

**Theoretical



dimensions

5540F

5

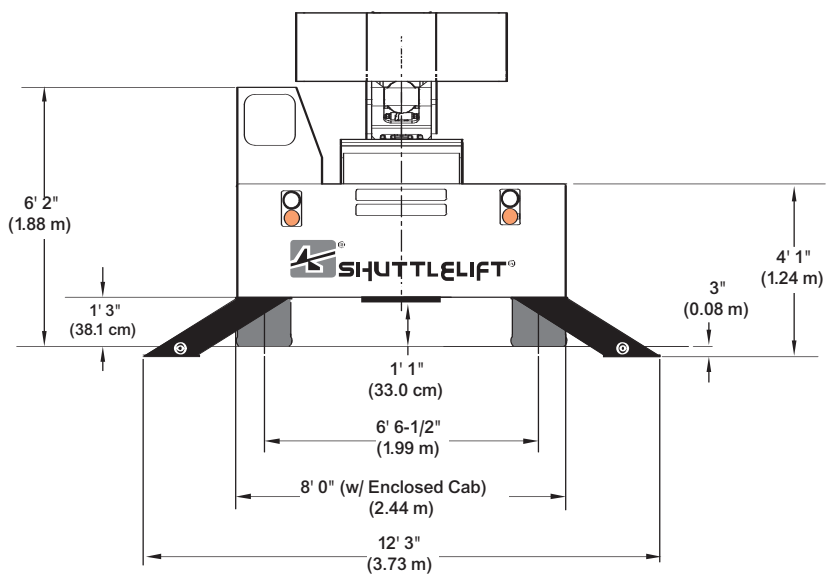
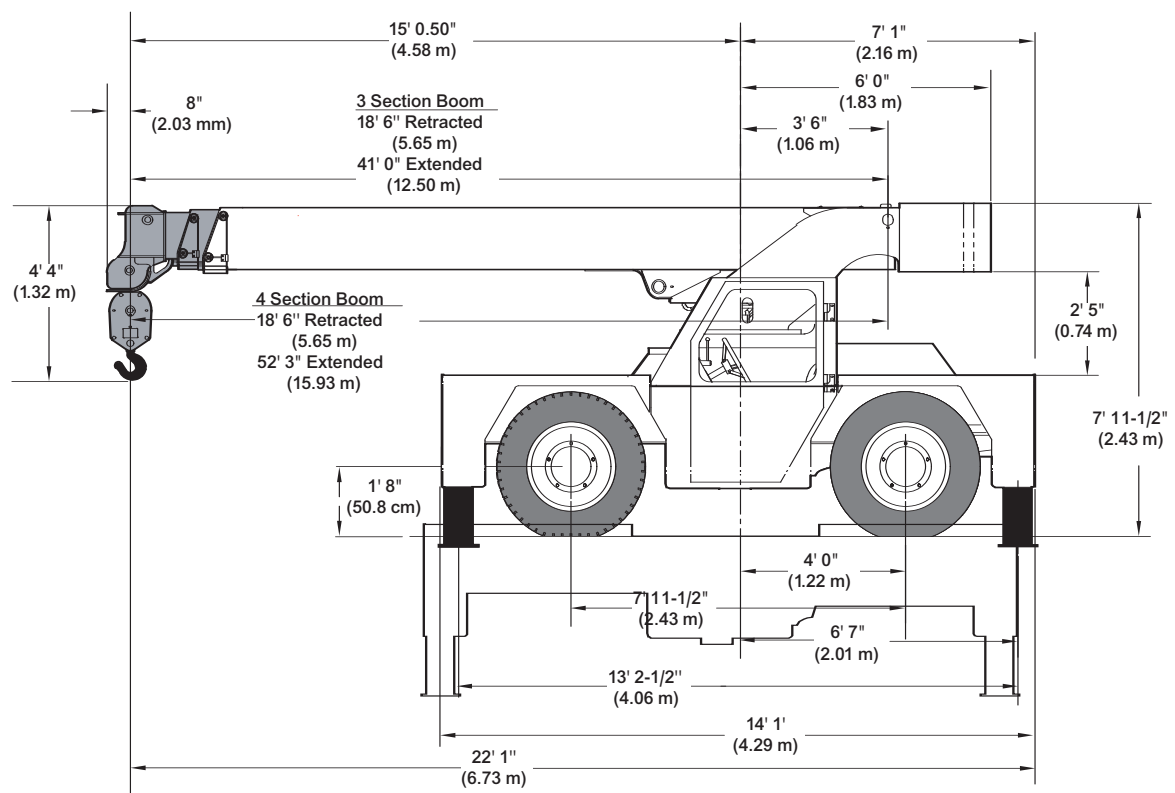

5500 Series





range diagram

3-SECTION BOOM

5540F

6

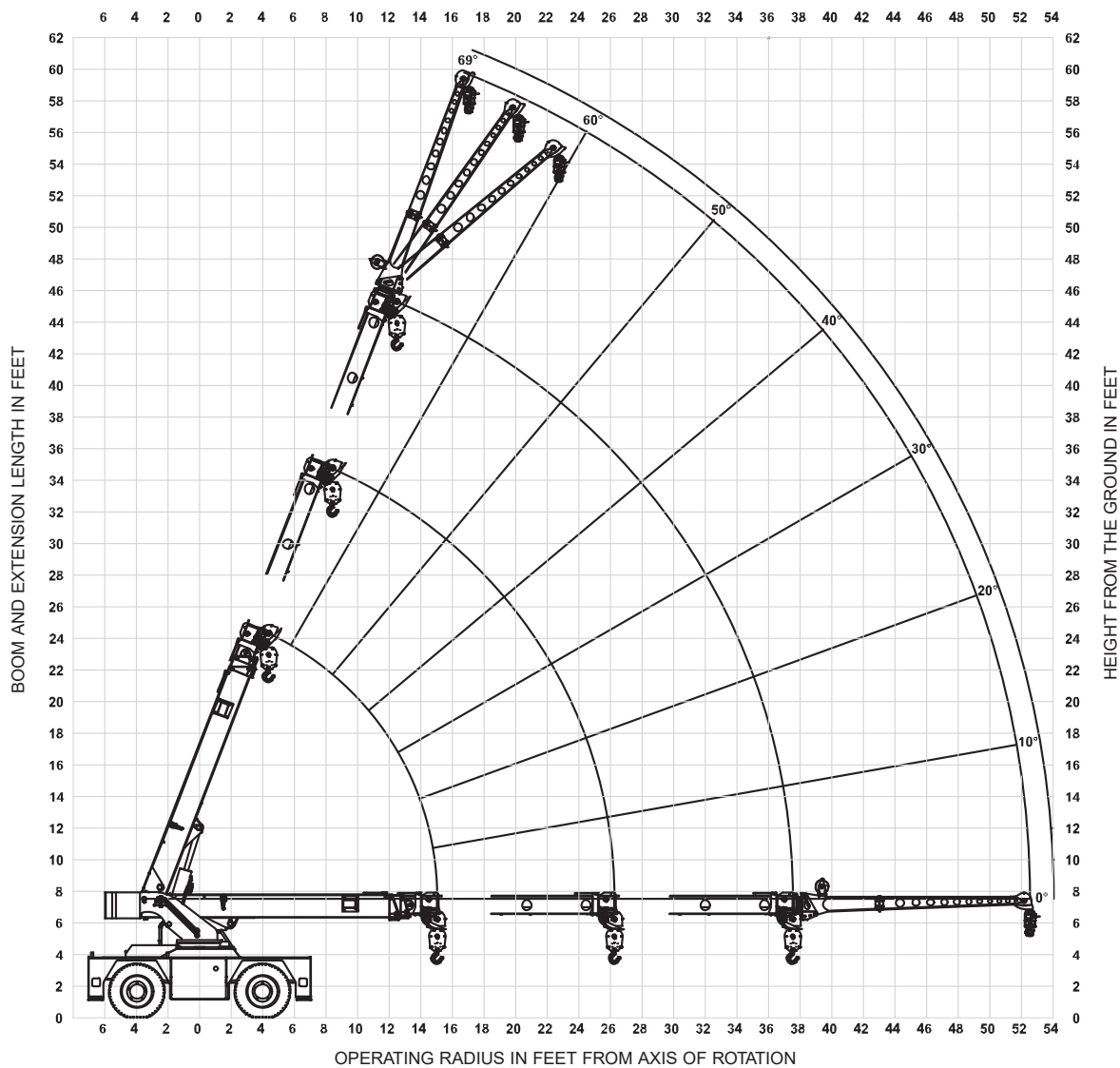

5500 Series

THIS CHART IS ONLY A GUIDE AND SHOULD NOT BE USED TO OPERATE THE CRANE. The individual crane's load chart, operating instructions and other instructional plates must be read and understood prior to operating the crane.





range diagram

5540F

4-SECTION BOOM

7

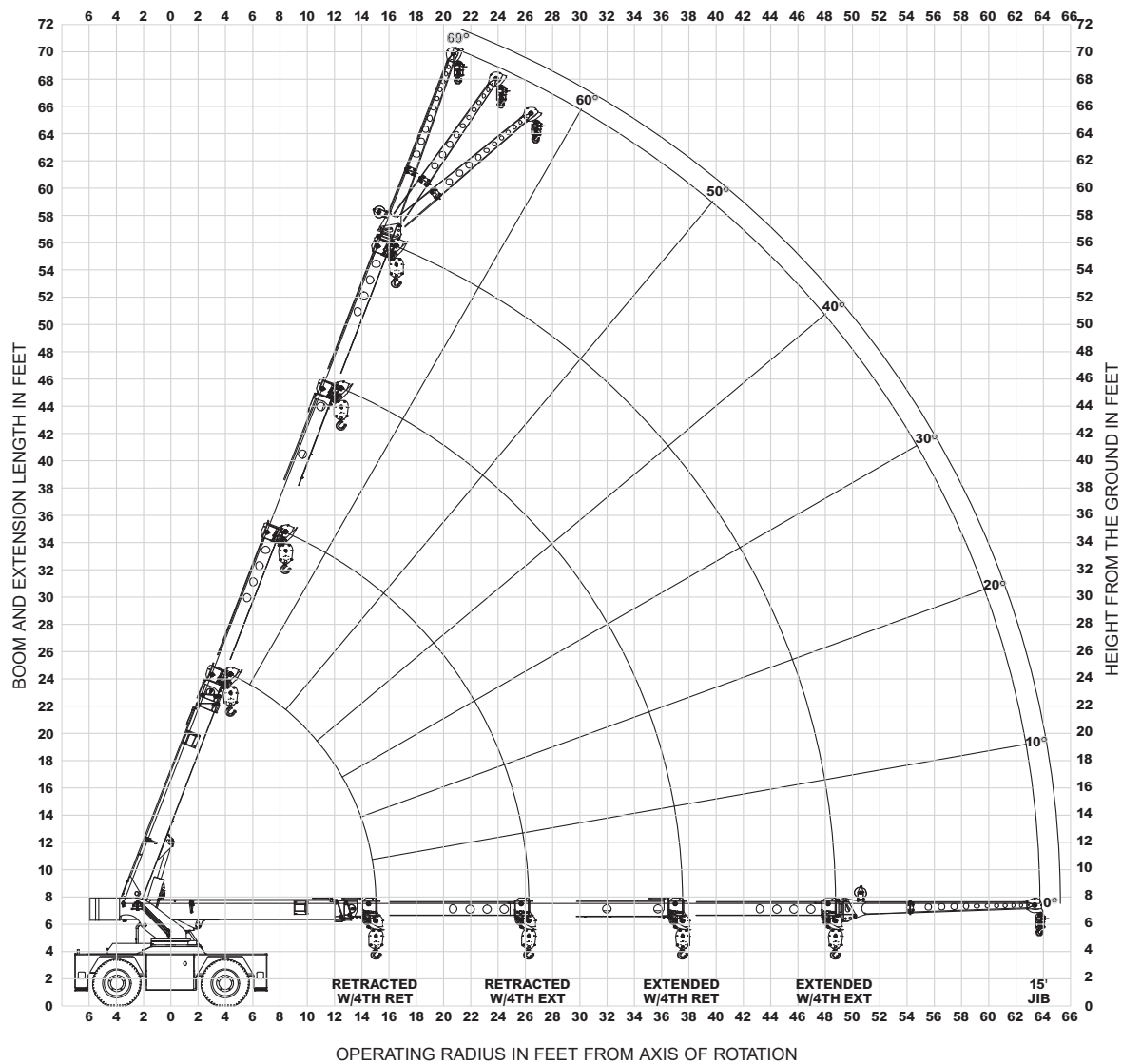

THIS CHART IS ONLY A GUIDE AND SHOULD NOT BE USED TO OPERATE THE CRANE. The individual crane's load chart, operating instructions and other instructional plates must be read and understood prior to operating the crane.

5500 Series



load chart

5540F w/3-section boom

8

	RADIUS (ft)	ON OUTRIGGERS (lbs)		ON RUBBER (lbs)	
		F/R	360°	F/R	360°
MAIN BOOM	6.0	30000	30000	17000	17000
	8.0	26200	26200	13500	14600
	10.0	22300	22300	10700	10880
	12.0	18600	18600	8710	8100
	14.0	14800	14800	7210	6000
	15.0	13000	13000	6600	5250
	16.0	12200	12200	6060	4760
	18.0	10800	10800	5120	3900
	20.0	9630	9180	4370	3190
	22.0	8640	7480	3710	2660
	24.0	7790	6210	3070	2200
	26.0	7040	5310	2620	1820
	28.0	6420	4740	2260	1530
	30.0	5700	4290	1990	1320
	32.0	5060	3920	1790	1160
	34.0	4510	3580	1610	1040
	36.0	4020	3260	1460	930
	37.5	3700	3060	1370	860
JIB	40.0	3480	2860	1270	800
	42.0	3310	2700	1190	740
	44.0	3130	2560	1120	690
	46.0	2960	2410	1040	640
	48.8	2710	2210	930	570
	52.5	2390	1940	790	480

MAIN BOOM ANGLE (deg)	JIB STRUCTURAL CAPACITIES (lbs)		
	0°	15°	30°
69	6000	3900	2800
65	5000	3500	2550
60	4300	3150	2350
55	3800	2850	2200
50	3400	2600	2100
45	3050	2400	2000
40	2800	2250	1950
35	2600	2150	1900
30	2400	2080	1850
25	2300	2050	-
20	2200	2000	-
15	2100	1950	-
10	2050	-	-
5	2020	-	-
0	2000	-	-

JIB CAPACITY IS LIMITED BY BOTH STRUCTURAL CAPACITY CHART AND MAIN CAPACITY CHART.

SHADED AREAS ARE GOVERNED BY STRUCTURAL STRENGTH, DO NOT RELY ON TIPPING.

OPERATION OF THIS EQUIPMENT IN EXCESS OF RATING CHARTS AND DISREGARD OF INSTRUCTIONS IS DANGEROUS AND VOIDS WARRANTY.

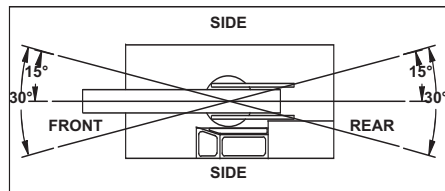

REDUCTION CHART		
	FROM MAIN BOOM RATINGS	FROM JIB RATINGS
MAIN BLOCK	210 lbs	N/A
HOOK & BALL	100 lbs	100 lbs
JIB, STOWED	0 lbs	N/A
JIB, DEPLOYED	700 lbs	0 lbs

RIGGING CHART	
<p>1-PART 0-7500 lbs</p>	<p>4-PART 0-30000 lbs</p>
<p>WIRE ROPE: 1/2 inch diameter Min. breaking strength 26250 lbs.</p>	

- The rated loads are the maximum lifting capacities as determined by operating radius only. Any combination of boom lengths and angles may be used to obtain operating radius. The operating radius is the horizontal distance from a projection of the axis of rotation to the supporting surface, before loading, to the center of vertical hoist line or tackle with load applied.
- The rated loads shown on outriggers do not exceed 85% of actual tipping. The rated loads shown on rubber do not exceed 75% of actual tipping. These ratings are based on freely suspended loads with the crane leveled, standing on a firm, uniform supporting surface. Practical working loads depend on supporting surface, operating radius and other factors affecting stability. Hazardous surroundings, climatic conditions, experience of operator and proper training must be taken into account by the operator.
- The weights of all load handling devices, such as hooks, hook blocks, slings, etc., except the hoist rope, shall be considered as part of the load. See reduction chart.
- Ratings on outriggers are with outriggers fully extended.
- Ratings on rubber depend on tire capacity, condition of tires and proper inflation pressure (120 psi). Loads on rubber may be transported at a maximum speed of 2.5 mph on a smooth, hard, level surface with the boom retracted to the shortest length possible and centered over the front.
- For operating radius not shown, use load rating of next larger radius.
- The maximum combined total boom and deck load is 16000 lbs. The maximum deck load only is 20000 lbs.
- Do not induce any external side loads to boom or jib.

5500 Series

THIS CHART IS ONLY A GUIDE AND SHOULD NOT BE USED TO OPERATE THE CRANE. The individual crane's load chart, operating instructions and other instructional plates must be read and understood prior to operating the crane.



load chart

5540F w/ 4-section boom

RADIUS (ft)	4TH RETRACTED				RADIUS (ft)	4TH EXTENDED			
	ON OUTRIGGERS (lbs)		ON RUBBER (lbs)			ON OUTRIGGERS (lbs)		ON RUBBER (lbs)	
	F/R	360°	F/R	360°		F/R	360°	F/R	360°
6.0	30000	30000	17000	17000	6.0	-	-	-	-
8.0	26200	26200	13500	14600	8.0	11000	11000	11000	11000
10.0	22300	22300	10700	11000	10.0	10700	10700	10700	10700
12.0	18600	18600	8710	7650	12.0	9250	9250	9250	9250
14.0	14800	14800	7210	5480	14.0	8290	8390	7760	7500
15.0	13000	13000	6600	4890	15.0	8200	8200	7150	6080
16.0	12200	12200	6060	4500	16.0	8110	8110	6610	5510
18.0	10800	10600	4950	3750	18.0	7950	7950	5680	4500
20.0	9630	8630	3980	3080	20.0	7820	7820	4730	3560
22.0	8640	7350	3230	2460	22.0	7710	7710	3980	3000
24.0	7790	6460	2720	1990	24.0	7630	7270	3410	2520
26.0	6800	5700	2360	1610	26.0	7100	6330	2940	2150
28.0	5820	5040	2100	1410	28.0	6590	5420	2550	1840
30.0	5020	4420	1880	1220	30.0	5710	4760	2190	1580
32.0	4400	3950	1650	1070	32.0	5180	4080	1880	1360
34.0	3930	3570	1460	920	34.0	4680	3570	1600	1160
36.0	3510	3190	1280	770	36.0	4250	3190	1370	990
37.5	3210	2890	1180	680	37.5	3830	2970	1240	880
40.0	2950	2600	1070	610	40.0	3400	2700	1070	740
42.0	2760	2430	970	550	42.0	3150	2490	960	630
44.0	2590	2250	890	500	44.0	2890	2300	870	540
46.0	2430	2090	800	450	46.0	2630	2130	790	470
48.8	2240	1850	680	380	48.8	2320	1930	710	370
52.5	2030	1480	500	290	52.5	2070	1710	590	280
58.0	-	-	-	-	58.0	1720	1380	420	170
63.8	-	-	-	-	63.8	1330	1020	230	60

MAIN BOOM ANGLE (deg)	JIB STRUCTURAL CAPACITIES (lbs)					
	4TH RETRACTED			4TH EXTENDED		
	0°	15°	30°	0°	15°	30°
69	6000	3900	2800	5180	3900	2800
65	5000	3500	2550	4970	3500	2550
60	4300	3150	2350	4300	3150	2350
55	3800	2850	2200	3800	2850	2200
50	3400	2600	2100	3400	2600	2100
45	3050	2400	2000	3050	2400	2000
40	2800	2250	1950	2800	2250	1950
35	2600	2150	1900	2600	2150	1900
30	2400	2080	1850	2400	2080	1850
25	2300	2050	-	2300	2050	-
20	2200	2000	-	2200	2000	-
15	2100	1950	-	2100	1950	-
10	2050	-	-	2050	-	-
5	2020	-	-	2020	-	-
0	2000	-	-	2000	-	-

9

JIB CAPACITY IS LIMITED BY BOTH STRUCTURAL CAPACITY CHART AND MAIN CAPACITY CHART.

SHADED AREAS ARE GOVERNED BY STRUCTURAL STRENGTH, DO NOT RELY ON TIPPING.

OPERATION OF THIS EQUIPMENT IN EXCESS OF RATING CHARTS AND DISREGARD OF INSTRUCTIONS IS DANGEROUS AND VOIDS WARRANTY.

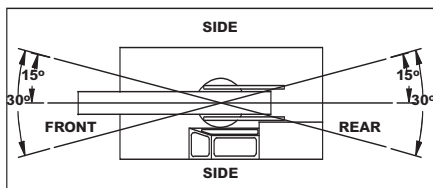

REDUCTION CHART		
	FROM MAIN BOOM RATINGS	FROM JIB RATINGS
MAIN BLOCK	210 lbs	N/A
HOOK & BALL	100 lbs	100 lbs
JIB, STOWED	0 lbs	N/A
JIB, DEPLOYED	700 lbs	0 lbs

RIGGING CHART	
1-PART 0-7500 lbs	4-PART 0-30000 lbs
WIRE ROPE: 1/2 inch diameter Min. breaking strength 26250 lbs.	

- The rated loads are the maximum lifting capacities as determined by operating radius only. Any combination of boom lengths and angles may be used to obtain operating radius. The operating radius is the horizontal distance from a projection of the axis of rotation to the supporting surface, before loading, to the center of vertical hoist line or tackle with load applied.
- The rated loads shown on outriggers do not exceed 85% of actual tipping. The rated loads shown on rubber do not exceed 75% of actual tipping. These ratings are based on freely suspended loads with the crane leveled, standing on a firm, uniform supporting surface. Practical working loads depend on supporting surface, operating radius and other factors affecting stability. Hazardous surroundings, climatic conditions, experience of operator and proper training must be taken into account by the operator.
- The weights of all load handling devices, such as hooks, hook blocks, slings, etc., except the hoist rope, shall be considered as part of the load. See reduction chart.
- Ratings on outriggers are with outriggers fully extended.
- Ratings on rubber depend on tire capacity, condition of tires and proper inflation pressure (120 psi). Loads on rubber may be transported at a maximum speed of 2.5 mph on a smooth, hard, level surface with the boom retracted to the shortest length possible and centered over the front.
- For operating radius not shown, use load rating of next larger radius.
- The maximum combined total boom and deck load is 16000 lbs. The maximum deck load only is 20000 lbs.
- Do not induce any external side loads to boom or jib.

THIS CHART IS ONLY A GUIDE AND SHOULD NOT BE USED TO OPERATE THE CRANE. The individual crane's load chart, operating instructions and other instructional plates must be read and understood prior to operating the crane.

5500 Series



dimensions

5560B

10

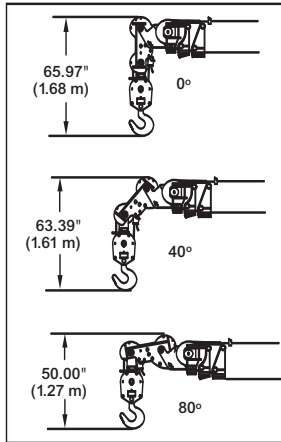

Dimensions are with the boom horizontal and the anti-two block bottomed.

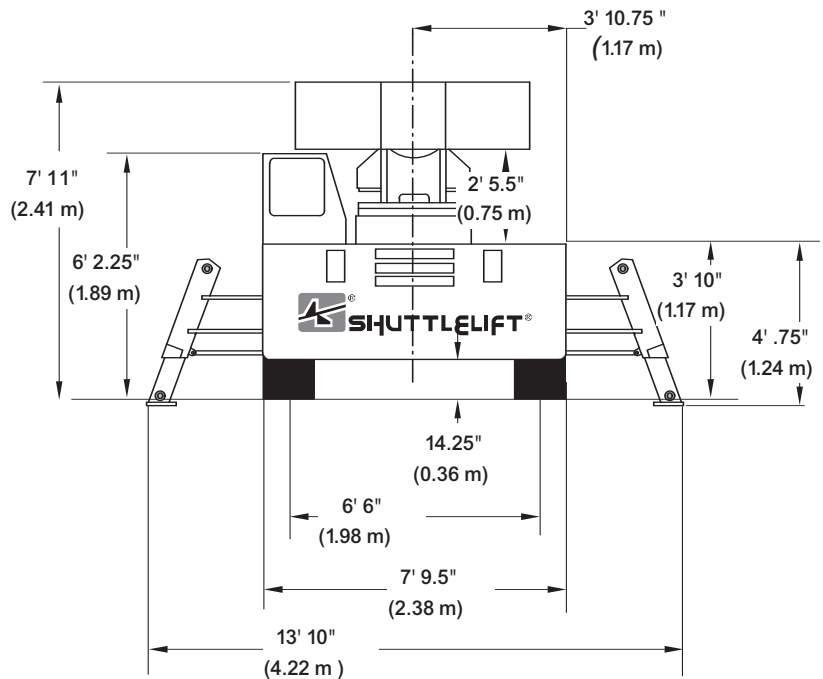
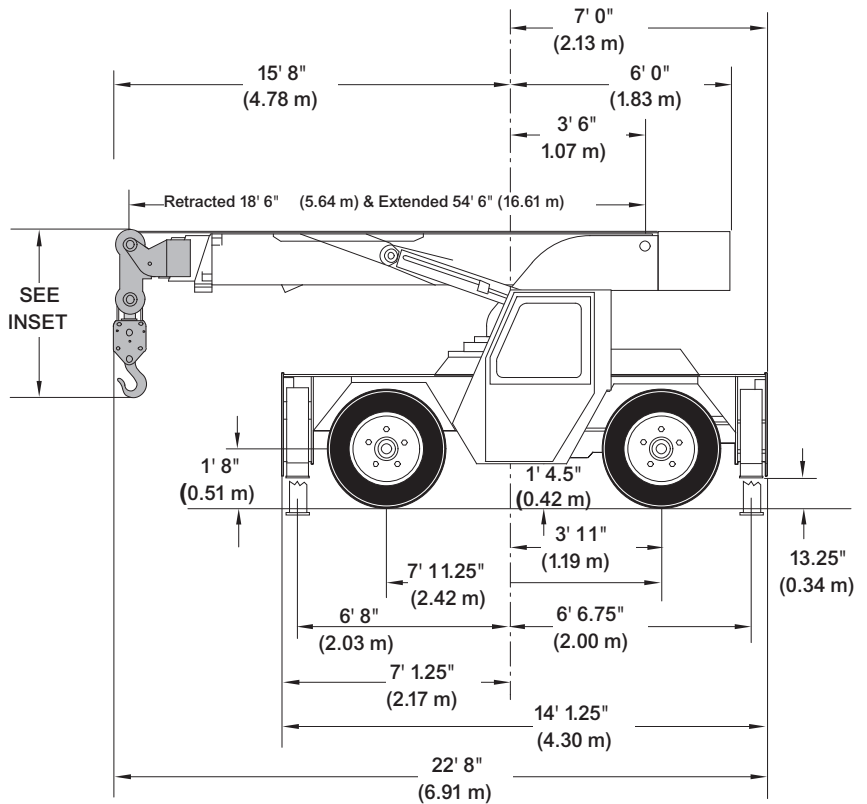

THIS CHART IS ONLY A GUIDE AND SHOULD NOT BE USED TO OPERATE THE CRANE. The individual crane's load chart, operating instructions and other instructional plates must be read and understood prior to operating the crane.

range diagram

5560B

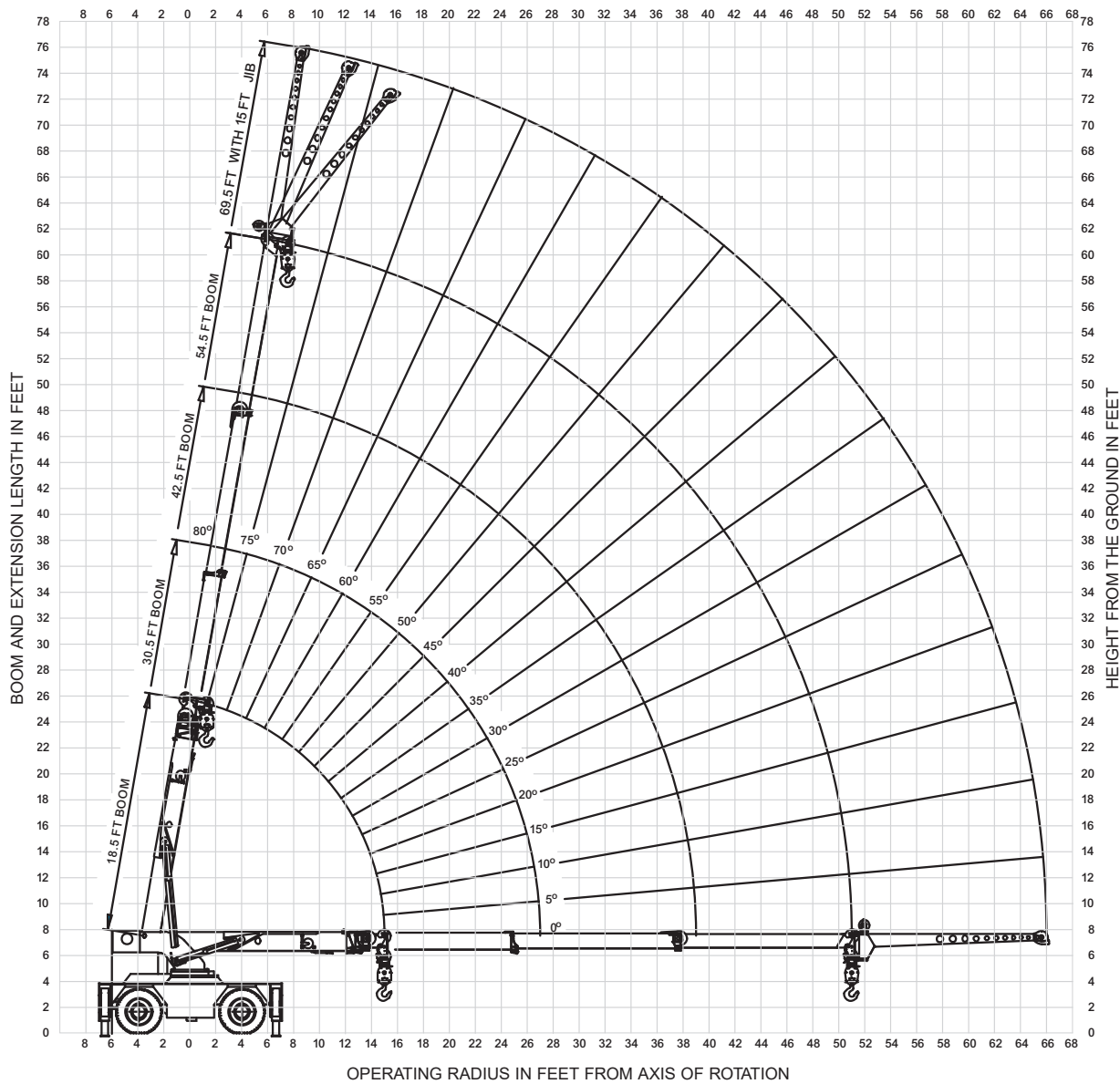

11

5500 Series

THIS CHART IS ONLY A GUIDE AND SHOULD NOT BE USED TO OPERATE THE CRANE. The individual crane's load chart, operating instructions and other instructional plates must be read and understood prior to operating the crane.



notes

13

5500 Series





notes

14

5500 Series





notes

15

5500 Series





Regional Headquarters

Americas

Manitowoc, Wisconsin, USA
Tel: +1 920 684 6621
Fax: +1 920 683 6278

Shady Grove, Pennsylvania, USA
Tel: +1 717 597 8121
Fax: +1 717 597 4062

Regional Offices

Americas

Brazil

Alphaville
Tel: +55 11 3103 0200
Fax: +55 11 4688 2013

Mexico

Monterrey
Tel: +52 81 8124 0128
Fax: +52 81 8124 0129

Europe, Middle East, Africa

Algeria

Hydra
Tel: +21 3 21 48 1173
Fax: +21 3 21 48 1454

Czech Republic

Netvorice
Tel: +420 317 78 9313
Fax: +420 317 78 9314

France

Baudemont
Tel: +33 385 28 2589
Fax: +33 385 28 0430

Cergy

Tel: +33 130 31 3150
Fax: +33 130 38 6085

Decines

Tel: +33 472 81 5000
Fax: +33 472 81 5010

Germany

Langenfeld
Tel: +49 21 73 8909-0
Fax: +49 21 73 8909 30

Hungary

Budapest
Tel: +36 13 39 8622
Fax: +36 13 39 8622

Italy

Parabiago
Tel: +390 331 49 3311
Fax: +390 331 49 3330

Europe, Middle East, Africa

Ecully, France
Tel: +33 472 18 2020
Fax: +33 472 18 2000

Netherlands

Breda
Tel: +31 76 578 3999
Fax: +31 76 578 3978

Poland

Warsaw
Tel: +48 22 843 3824
Fax: +48 22 843 3471

Portugal

Alfena
Tel: +351 229 69 8840
Fax: +351 229 69 8848

Lisbon

Tel: +351 212 109 340
Fax: +351 212 109 349

Russia

Moscow
Tel: +7 495 641 2359
Fax: +7 495 641 2358

U.A.E.

Dubai
Tel: +971 4 3381 861
Fax: +971 4 3382 343

U. K.

Middlesex
Tel: +44 1 895 43 0053
Fax: +44 1 895 45 9500

Sunderland

Tel: +44 191 522 2000
Fax: +44 191 522 2052

Asia – Pacific

Australia

Brisbane
38 Suscatand Street
Rocklea Queensland 4106
Tel: +617 3274 5879
Fax: +617 3274 6558

Melbourne

1/46 Venture Drive
Sunshine West VIC 3020
Tel: +(03) 9336 1322
Fax: +(03) 9336 1300

Sydney

142 Magowar Road
Girraween, NSW 2145
Tel: +61 02 9896 4433
Fax: +61 02 9896 3122

Asia – Pacific

Shanghai, China
Tel: +86 21 51113579
Fax: +86 21 51113578

Singapore

Tel: +65 6264 1188
Fax: +65 6862 4142

China

Beijing
Tel: +86 10 58674761
Fax: +86 10 58674760

Xi'an

Tel: +86 29 87891465
Fax: +86 29 87884504

Korea

Seoul
Tel: +82 2 3439 0400
Fax: +82 2 3439 0405

Philippines

Makati City
Tel: +63 2 844 9437
Fax: +63 2 844 4712

Factories

Brazil
Alphaville

China
Zhangjiagang

France
Charlieu
La Clayette
Moulines

Germany
Wilhelmshaven

India
Calcutta
Pune

Italy
Niella Tanaro

Portugal
Baltar
Fânzeres

Slovakia
Saris

U.S.A.
Manitowoc
Port Washington
Shady Grove



Constant improvement and engineering progress make it necessary that we reserve the right to make specification, equipment and price changes without notice. Illustrations shown may include optional equipment and accessories, and may not include all standard equipment.

©2008 MANITOWOC
Printed in USA
Form No. 5500 Series
Part No. 07-009 / 0808 / 1M



www.manitowoc.com