

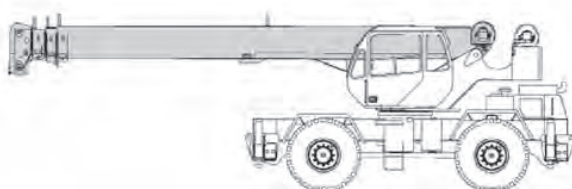

## Rough Terrain Crane Specifications

## RT200/200XL



### STANDARD BOOM EQUIPMENT

#### BOOM

30-94' (9.23-28.78 m), four section full power boom. Telescoping is mechanically synchronized with single lever control. The synchronization system consists of a single telescope cylinder and high strength leaf chains to extend and retract the third section and tip section. Boom is high strength four plate design, welded inside and out, with anti-friction slide pads. Boom side plates are made with stamped impressions to reduce weight and increase strength. A single boom hoist cylinder provides for boom elevation of -4 to 76 degrees. All cylinders are equipped with integral hold valves. Maximum tip height is 99' (30.17 m).

#### BOOM HEAD

Welded to outer section of boom. Four or five metallic load sheaves and two idler sheaves mounted on heavy duty, anti-friction bearings. Quick reeving boom head. Provisions made for side-stow jib mounting.

### OPTIONAL BOOM EQUIPMENT

#### MAIN BOOM

30-72' (9.23-22.19 m) three section full power boom **OR** 30-100' (9.23-30.61 m) four section full power XL Series boom.

Telescoping is mechanically synchronized with single lever control. The synchronization system consists of a single telescope cylinder and high strength leaf chains to extend and retract the tip section. Either boom is high strength four plate design, welded inside and out, with anti-friction slide pads. Boom side plates are made with stamped impressions to reduce weight and increase strength. A single boom hoist cylinder provides for boom elevation of -4 to 76 degrees. All cylinders are equipped with integral hold valves. Maximum tip height is 72' (22.19 m) boom options 79' (24.23 m). Maximum tip height with 100' (30.61 m) XL Series boom option is 107' (32.76 m)

#### AUXILIARY BOOM HEAD

Removable auxiliary boom head has single metallic sheave mounted on an anti-friction bearing. Removable pin-type rope guard for quick reeving. Installs on main boom peak only. Removal is not required for jib use.

#### HOOK BLOCK

Two, three or four metallic sheaves on anti-friction bearings with hook and hook latch. Quick reeving design does not require removal of wedge and socket from rope.

#### HOOK & BALL

7 ton (6.3 mt) top swivel ball with hook and hook latch

#### JIBS

26' (7.92 m) side stow swing-on one-piece lattice type jib. Single metallic sheave mounted on anti-friction bearing. Jib is offsettable at 0°, 15° or 30°. With 100' (30.61 m) XL Series boom, maximum tip height is 130' (39.62 m). 26-43' (7.92-13.11 m) side stow swing-on lattice type jib. Single sheave mounted on anti-friction bearing. Jib is extendible to 43' (13.11 m) by means of 17' (5.18 m) manual pull-out tip section, roller supported for ease of extension. Jib is offsettable at 0°, 15° or 30°. With 100' (30.61 m) XL Series boom, maximum tip height is 147' (44.80 m).



## ROUGH TERRAIN CRANE RT200/200XL

### STANDARD UPPERSTRUCTURE EQUIPMENT

#### UPPERSTRUCTURE FRAME

All welded one-piece structure fabricated with high tensile strength alloy steel. Counterweight is bolted to frame.

#### TURNTABLE CONNECTION

Swing bearing is a single row, ball type, with external teeth. The swing bearing is bolted to the revolving upperstructure and welded to the carrier frame.

#### SWING

A hydraulic motor drives a double planetary reduction gear for precise and smooth swing function. Swing speed (no load) is 3.0 rpm.

#### SWING BRAKE

Heavy duty multiple disc swing brake is mechanically actuated from operator's cab by foot pedal. Brake may be locked on or used as a momentary brake. A separate 360° mechanical house lock is also provided.

#### RATED CAPACITY INDICATOR

Rated Capacity Indicator with visual and audible warning system and automatic function disconnects. Second generation pictographic display includes: boom radius, boom angle, boom length, allowable load, actual load, and percentage of allowable load registered by bar graph. Operator settable alarms provided for swing angle, boom length, boom angle, tip height, and work area exclusion zone. Anti-two block system includes audio/visual warning and automatic function disconnects.

#### OPERATORS CAB

Environmental cab with all steel construction, optimized visibility, tinted safety glass throughout, and rubber floor matting is mounted on vibration absorbing pads. The cab has a sliding door on the left side, framed sliding window on the right side, hinged tinted all glass skylight and removable front windshield to provide optimized visibility of the load open or closed. Acoustical foam padding insulates against sound and weather. The deluxe six-way adjustable operator's seat is equipped with a mechanical suspension and includes head and arm rests.

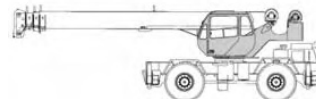

#### CONTROLS

All control levers and pedals are positioned for efficient operation. Hand operated control levers include swing, telescope, boom hoist, winch(s), shift, vernier adjustable hand throttle and 360° house lock. Switches include ignition, engine stop, two speed winch(s), lights, horn, windshield wipers, defroster, steering mode, parking brake, and outrigger controls. Foot control pedals include swing brake, boom raise, boom lower, service brakes and accelerator.

#### INSTRUMENTATION AND ACCESSORIES

In-cab gauges include air pressure, bubble level, engine oil pressure, fuel, engine temperature, voltmeter, transmission temperature, and transmission oil pressure. Indicators include low air, high water temperature/ low oil pressure/high transmission temperature audio/visual warning, low coolant audio/visual warning, hoist drum rotation indicator(s), and Rated Capacity Indicator. accessories include fire extinguisher; light package including headlights, tail lights, dome light, brake lights, directional signals, four-way hazard flashers, dome light, and back up lights with audio pulsating back-up alarm; windshield washer/ wiper and skylight wiper, R.H. and L.H. rear view mirrors; dash lights; and seat belt. Circuit breakers protect electrical circuits.

#### HYDRAULIC CONTROL VALVES

Valves are mounted on the upperstructure and are easily accessible. Valves are mechanically operated and include one four spool valve for boom elevation, telescope, main winch boost, and main winch; one single spool valve for swing. High pressure regeneration feature provides 2-speed boom extension. Quick disconnects are provided for ease of installation of pressure check gauges.

#### OPTIONAL EQUIPMENT

Auxiliary Winch, Heater/Defroster, Air Conditioner, Work Lights, Revolving Amber Light, Independent Rear Wheel Steering, Roof Mounted Spotlight.

### STANDARD CARRIER EQUIPMENT

#### CARRIER CHASSIS

High strength chassis with four-wheel drive and four-wheel steer (4x4x4). Has box beam type construction with reinforcing cross members, a precision machined turntable mounting plate and integrally welded outrigger boxes. Decking has skid-resistant surfaces, including tool storage compartment, and access steps and handles left and right side and front and rear corners.

#### AXLES AND SUSPENSION

Rear axle is a planetary drive/steer type with 10.0" (0.25 m) of total oscillation. Automatic oscillation lockouts engage when the superstructure is swung 10° in either direction. An oscillation lock out override is provided. Front axle is a planetary drive/steer type, rigid mounted to the frame for increased stability.

#### WHEELS & TIRES

Disc type wheels with full tapered bead seat rim. 134" (3.40 m) wheelbase.

#### TIRES

Standard: 20.5 x 25,24 P.R. / Optional: 16.00 x 25, 28 P.R.

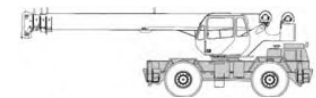

#### SERVICE BRAKES

Air over hydraulic drum type brakes on all four wheels: 17" x 4" (43.18 x 10.2 cm) drum brakes

#### PARKING BRAKE

Transmission mounted spring-set, air released external caliper disk type emergency/parking brake.

#### STEERING

Hydraulic four-wheel power steering for two-wheel, four-wheel, or crab steer is easily controlled by steering wheel. A rear axle centering light is provided.



## ROUGH TERRAIN CRANE RT200/200XL

### STANDARD CARRIER EQUIPMENT (CONTINUED)

Turning radius to center of outside tire.	(16.00 x 25)	(20.5 x 25)
Two-wheel:	34' 8.81" (10.5 m)	34' 10.38" (10.63)
Four-wheel:	19' 3.44 (5.88 m)	19' 5" (5.92 m)

### TRANSMISSION

Range-shift type power-shift transmission with integral torque converter has neutral safety start, 6 speeds forward, and 6 speeds reverse. Automatic pulsating back-up alarm.

### MULTI-POSITION OUT & DOWN OUTRIGGERS

Fully independent hydraulic outriggers may be utilized fully extended, in their 1/2 extended position, or fully retracted. Easily removable steel floats, each with an area of 254<sup>2</sup> (1 639 cm<sup>2</sup>) stow on the carrier frame. Complete controls and sight leveling bubble are located in the operators' cab.

### OPTIONAL EQUIPMENT

Cold Weather Starting Aid, Immersion Heater, Pintle Hook, Clearance Lights, Front Mounted Winch - 20,000 lb (9 072 kg), Independent Rear or Four Mode Rear Wheel Steer.

### HYDRAULIC SYSTEM

#### HYDRAULIC PUMPS

Three gear type pumps, one single and two in tandem, driven off the transmission. Combined system capability is 113 gpm (427.7 lpm). Includes manual pump disconnect.

- ▶ **Main Winch Pump**  
53 gpm (200.7 lpm) @ 3,500 psi (246.1 kg/cm<sup>2</sup>)
- ▶ **Boom Hoist and Telescope Pump**  
39 gpm (147.6 lpm) @ 3,500 psi (246.1 kg/cm<sup>2</sup>)
- ▶ **Power Steering, Outrigger and Winch Boost Pump**  
21 gpm (79.5 lpm) @ 2,500 psi (175 kg/cm<sup>2</sup>) Always live even when pump disconnect is actuated.

#### FILTRATION

Full flow oil filtration system with bypass protection includes a removable 60 mesh (250 micron) suction screen-type filter and 5 micron replaceable return line filter.

#### HYDRAULIC RESERVOIR

All steel, welded construction with internal baffles and diffuser. Provides easy access to filters and is equipped with an external sight level gauge. The hydraulic tank is pressurized to aid in keeping out contaminants and in reducing potential pump cavitation. Capacity is 94 gal (355 liters). Swing-away hydraulic oil cooler is standard

### MAIN WINCH SPECIFICATIONS

Hydraulic winch with bent axis piston motor and planetary reduction provides 2-speed operation with equal speeds for power up and down. Winch is equipped with an integral automatic brake, a grooved drum with tapered flanges for improved rope spooling, a spring loaded cable roller and an electronic drum rotation indicator.

Performance	LO-Range	HI-Range
▶ Max line speed (no load)		
▶ First layer	205 fpm (62.5 m/min)	329 fpm (100.3 m/min.)
▶ Fifth layer	297 fpm (90.5 m/min)	475 fpm (144.8 m/min.)
▶ Max. line pull-first layer	12,512 lb (5 675 kg)	7,298 lb (3 310 kg)
▶ Max. line pull-fifth layer	8,662 lb (3 929 kg)	5,052 lb (2 292 kg)
▶ Permissible line pull	9,000 lb (4 082 kg)	

Drum Dimensions	Drum Capacity
▶ 10.62" (270 mm) drum diameter	Max. Storage: 598' (182.3 m)
▶ 17.53" (445 mm) length	6th layer is not a working layer
▶ 18.25" (464 mm) flange dia.	Max. useable: 479' (146.0 m)*
▶ Cable: 5/8" x 450' (16 mm x 137.2 m)	
▶ Cable type: 5/8" (16 mm) 6x19 IWRC right regular lay, preformed.	
▶ Min. breaking strength 17.9 tons (16.2 mt)	

\*Based on minimum flange height above top layer to comply with ANSI B30.5

### OPTIONAL AUXILIARY WINCH

Hydraulic winch with bent axis piston motor, power up and down, equal speed, planetary reduction with integral automatic brake, cable roller, and rotation indicator.

<b>Performance</b>	(Same as main winch)
<b>Drum Dimensions and Capacity</b>	(Same as main winch)

### OPTIONAL HOIST LINE

**Main winch and optional auxiliary winch:** 5/8" (16 mm) rotation resistant compacted strand 18 x 19 or 19 x 19. Min. breaking strength 22.6 tons (20.6 mt).

### ENGINE SPECIFICATIONS

Make and Model	Standard Cummins 6BTA5.9
Type	6 Cylinder
Bore and Stroke	4.02x4.72" (102x120 mm)
Displacement	359 cu in (5.9 L)
Max. Gross HP	130 hp (97 kw)@2500 rpm
Max. Gross Torque	384 lb•ft (521 N•m) @1200 rpm
Aspiration	Turbocharged
Air Filter	Dry Type
Electrical System	12 volt
Alternator	102 amp
Battery	(2) 12V-1600 C.C.A.
Fuel Capacity	50 gal (189 L)

### PERFORMANCE (STANDARD ENGINE)

Transmission Range	Gear	Forward Drive	Max. Speed	Max. Tractive Effort	Gradeability @ Stall
Low	1	4-Wheel	2.3 mph	37,856 lb	112.34%
			3.7 km/h	17 171 kg	
			4.4 mph	19,254 lb	39.84%
High	1	2-Wheel	7.1 km/h	8 734 kg	11.10%
			12.4 mph	6,431 lb	
			20.0 km/h	2 917 kg	34.04%
High	2	2-Wheel	5.0 mph	16,893 lb	
			8.0 km/h	7 663 kg	
			9.5 mph	8,589 lb	15.59%
High	3	2-Wheel	15.3 km/hr	3 896 kg	
			24.5 mph	2,849 lb	3.77%
			39.4 km/h	1 292 kg	

All performance data is based on a gross vehicle weight of 52,000 lb (23 583 kg). 16:00 x 25 tires, 4x4 drive. Performance may vary due to engine performance. Gradeability data is theoretical and is limited by tire slip, machine stability, or engine oil pan design.



### GENERAL DIMENSIONS

- 1. Dimensions given assume the boom is fully retracted in travel position and 16:00 x 25 tires. 20.5 tires reduce heights 1.0 (25 mm)
- 2. Minimum ground clearance under transmission - 20.62" (.52m)  
axle bowls - 19.12" (.49 m)  
tire rods - 20.38" (.52 m)
- 3. Track width: 6' 7.50" (2.02 m) 16:00 x 25 tires  
6' 10.5" (2.10 m) 20.5 x 25 tires
- 4. Width of carrier: 8' (2.44 m) 16:00 x 25 tires  
8' 8" (2.64 m) 20.5 x 25 tires

Tire to frame angle	16:00 tires	20.5 tires
Approach angle:	25.1°	24.1°
Departure angle:	23.1°	22.2°

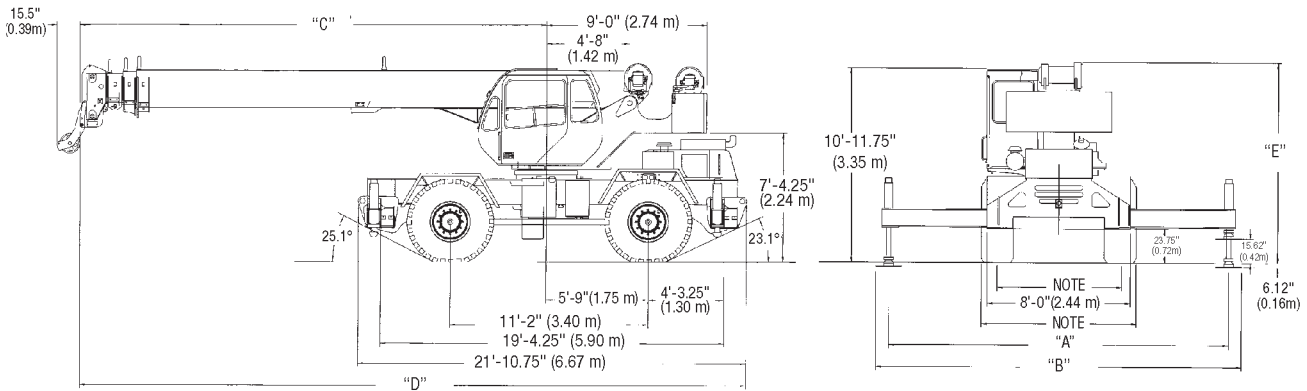

	"A"	"B"	Boom Length	"C"	"D"	"E"
Fully extended outriggers	19'-0" (5.79m)	20'-6" (6.25m)	32' (9.75m) Boom	15'-10" (4.83m)	27'-1" (8.25m)	12'-9.38" (3.90m)
Pinned outriggers	13'-2" (4.01m)	14'-8" (4.47m)	72' (22.19m) Boom	26'-4" (8.03m)	37'-7" (11.46m)	11'-7.5" (3.54m)
Fully retracted outriggers	7'-4.5" (2.25m)	8'-10.5" (2.71 m)	94' (28.78m) Boom	26'-4" (8.03m)	37'-7" (11.46m)	11'-7.5" (3.54m)
			100' (30.61m) Boom	28'-4" (8.64m)	39'-7" (12.06m)	11'-7.5" (3.54m)

WEIGHTS & AXLE LOADS	GROSS WEIGHT LB	UPPER FACING FRONT		GROSS WEIGHT KG	UPPER FACING FRONT	
		FRONT	REAR		FRONT	REAR
Basic Crane with 10,000 lb (4 536 kg) Counterweight	55,930	28,972	26,958	25 369	13 141	12 228
Add Options:						
26' (7.92 m) Swing-on Jib (Stowed)	+ 1100	+ 2,000	- 900	+ 499	+ 907	- 408
26'-43' (7.92-13.11 m) Swing-on Jib (Stowed)	+ 1500	+ 2,600	- 1,100	+ 680	+ 1 179	- 499
Auxiliary Boom Head	+ 100	+ 300	- 200	+ 45	+ 136	- 91
Auxiliary Winch with Wire Rope, Controls, Etc.	+ 115	- 25	+ 140	+ 52	- 11	+ 63
30 ton (27.2 mt) 4 Sheave Hook Block	+ 655	+ 1,071	- 416	+ 297	+ 486	- 189
30 ton (27.2 mt) 3 Sheave Hook Block	+ 670	+ 1,099	- 429	+ 304	+ 498	- 194
25 ton (22.6 mt) 2 Sheave Hook Block	+ 682	+ 1,117	- 435	+ 309	+ 507	- 198
7 ton (6.3 mt) Hook and Ball (in tool box)	+ 240	+ 290	- 50	+ 109	+ 130	- 21
PinTle Hook: Front	+ 45	+ 60	- 15	+ 20	+ 27	- 7
Rear	+ 45	- 25	+ 70	+ 20	- 11	+ 31
Substitute:						
72' (22.19 m) Full Power 3-Section Boom	- 3190	- 4,335	+ 1,145	- 1 445	- 1 965	+ 520
100' (30.61 m) Full Power 4-Section Boom	+ 533	+ 1,986	- 1,453	+ 242	+ 901	- 659
16.00 x 25 Tires	- 360	- 180	- 180	- 164	- 82	- 82

Note: Weights are for Terex supplied equipment and are subject to 2% variation due to manufacturing tolerances.