



SPECIFICATIONS

RT 190

90 Ton (82 tonne) Capacity
Century Series Rough Terrain Crane



 **TEREX CRANES, INC.**

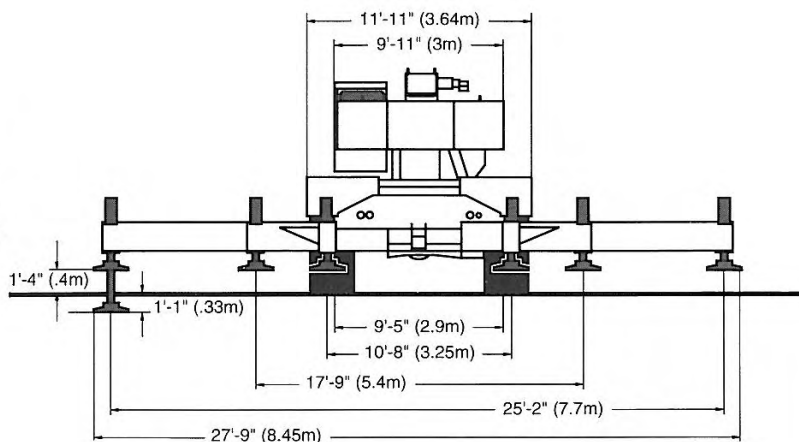

RT 190 FEATURES

- **Full Power 4-Section Boom:**
124 ft. 8 in. (38 m) makes it the longest in its class.
- **Lattice Extensions:**
A telescopic lattice extension plus a lattice extender insert yields a maximum tip height of 205 ft. (62.5 m).
- **Moveable:**
Can be brought to transport weight without removing the boom. Swingaway, tires and rims, and counterweight are all easily removed to reduce the overall weight to under 90,000 lbs. (40824 kg).
- **Matched Winches:**
Bent axis motors give you smooth operation and the highest maximum line pull of any rough terrain crane.
- **Three Outrigger Positions:**
Set the outriggers straight down, at the mid-point, or fully extended for optimum set-up on a congested work site.
- **Pride Plus Warranty:**
The most comprehensive warranty in the business. Covers the entire crane for 12 months or 2,000 hours of operation. Plus, major weldment structures are covered for 5 years or 10,000 hours.

This crane meets the requirements of ANSI B30.5. The machine structure has been tested per SAE J1063. The machine stability has been tested per SAE J765.

BOOM

39 ft. 4 in. to 124 ft. 8 in. (12 m to 38 m) four-section full-power telescopic boom. Boom point has six non-metallic main sheaves and two non-metallic idler sheaves. Metallic sheaves are available. A mechanical boom angle indicator is provided.

Boom Telescope:

One two-stage double-acting cylinder and a chain crowd mechanism. Fully synchronous operation in three- or four-section modes.

Boom Hoist:

Two-double-acting cylinders provide elevation from -2 degrees to 82 degrees. Easy Ride, a boom stabilizing system to reduce machine bounce during travel, is an option.

BOOM OPTIONS

Lattice Extension:

Swingaway, 32 ft. 10 in. (10 m), self-storing on base section of main boom. Offsettable to 30 degrees.

Telescopic Lattice Extension:

Swingaway 32 ft. 10 in. to 57 ft. 5 in. (10 m to 17.5 m), self-storing on the base section of main boom. Offsettable to 30 degrees.

Lattice Extender Insert:

16 ft. 5 in. (5 m) insert mounts between boom point and swingaway.

Auxiliary Boom Point:

Mounted at boom point with single sheave.

COUNTERWEIGHT

18,500 lbs. (8392 kg) bolt on type.

COUNTERWEIGHT OPTION

Self-removable style, for reducing overall weight for transport.

CAB

All-weather environmental cab of steel has locking door and opening ceiling, side, and rear windows with tinted safety glass throughout. Operator's cloth-covered seat is fully adjustable and has shock-absorbing suspension and seat belt. Steering column tilts and telescopes for comfort. Cab is cushion-mounted for vibration dampening and noise reduction. Contains all roading and crane function controls including armrest-mounted joystick or twin lever controls for swing, auxiliary winch, main winch, and boom hoist. Foot pedals for swing brake, boom telescope, service brakes and engine throttle.

Front console includes gauges for engine water temperature, engine oil pressure, hydraulic oil temperature, transmission oil temperature, air pressure and fuel. Also includes hourmeter, speedometer, tachometer, voltmeter, winch high speed indicator, rear steer centering light, engine condition warning system, anti-two block warning device and electronic LMI. Additional cab equipment includes windshield wiper and washer, defroster fan, interior cab light, fire extinguisher, machine level gauge, electric horn and hand throttle.

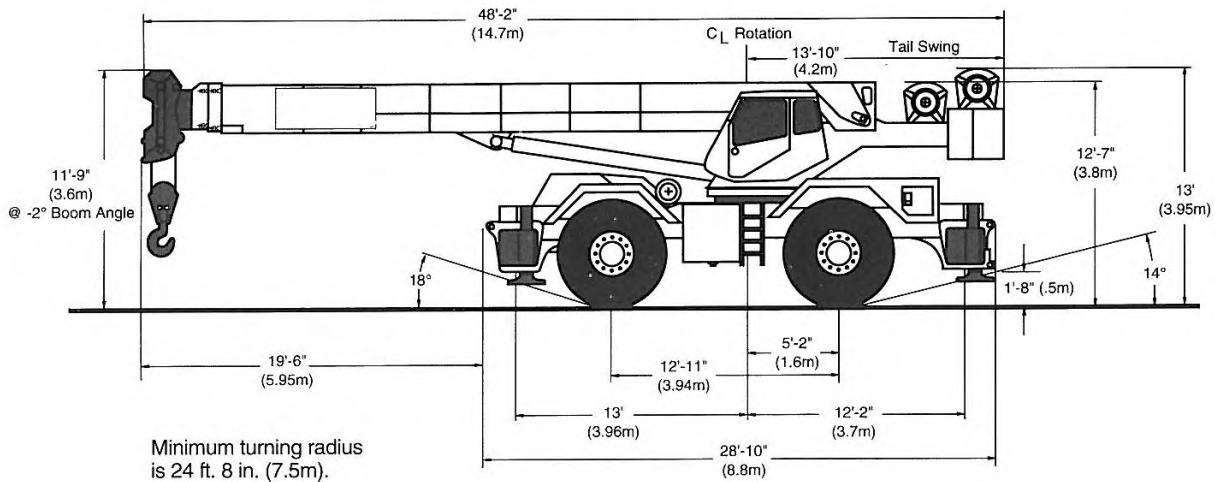

With 29.5 X 29 tires, add 2" to height dimensions.
 With 33.25 X 29 tires, add 4" to height dimensions and 4" to overall width.

WINCH

2080:

Two-speed with bent axis piston motor, planetary gearing with equal speed power raising and lowering, and infinitely variable speed control. Has automatic multi-disc brake and drum turn indicator.

Drum Capacity:

780 ft. (238 m) of 3/4 in. (19 mm) wire rope.

Wire Rope:

690 ft. (210 m) of 3/4 in. (19 mm) diameter, 6x37 EIPS with 7x7 IWRC.

Strength Limit:

16,800 lbs. (7620 kg) with 3.5:1 safety factor.

Line Pull (Max):

22,410 lbs. (10165 kg) first layer, low speed.

Line Pull (Permissible):

16,000 lbs. (7256 kg) per part of line.

Line Speed (Max):

441 fpm (134 mpm) fifth layer, high speed.

HOISTING OPTIONS

Auxiliary Winch:

Same as main winch. Wire rope is optional.

Auxiliary Winch:

1580 two-speed with bent axis piston motor, planetary gearing with equal speed power raising and lowering, and infinitely variable speed control. Has automatic multi-disc brake and drum turn indicator. Wire rope is optional.

Drum Capacity:

554 ft. (168 m) of 3/4 in. (19 mm) wire rope.

Strength Limit:

16,800 lbs. (7620 kg) with 3.5:1 safety factor on 3/4 in. (19 mm) diameter, 6x37 EIPS with 7x7 IWRC wire rope.

Line Pull (Max):

17,100 lbs. (7757 kg) first layer, low speed.

Line Pull (Permissible):

11,000 lbs. (4990 kg) per part of line.

Line Speed (Max):

631 fpm (192 mpm) fifth layer, high speed.

Auxiliary Winch Wire Rope:

3/4 in. (19 mm) diameter, 6x37 EIPS with 7x7 IWRC or rotation-resistant 8x19 EIPS with 7x7 IWRC. Length is 690 ft. (210 m) with 2080 winch and 550 ft. (168 m) with 1580 winch.

Cable Spooling Device:

For main or auxiliary winches.

Hook Blocks:

90 ton (82 tonne) with six sheaves, or 20 ton (18 tonne) with one sheave.

Headache Ball:

15 ton (13.5 tonne) weighted hook.

SWING UNIT

360 degree continuous rotation to 1.5 rpm with disc brake, integral with swing reducer.

House Lock:

Manually engaged 360 degree house lock.

HYDRAULIC SYSTEM

System uses two tandem gear-type pumps with a total flow of 145 gpm (547 lpm). Filtration is by two 10-micron return line filters externally mounted to the reservoir and one 20-micron pressure line filter. An oil cooler and manual disconnect are standard.

Oil Reservoir:

330 gallon (1250 liter) capacity.

CARRIER

Outriggers:

Independent, out and down type with control from the cab. The outriggers may be set in three positions for optimum setup on congested job sites with a full extension of 25 ft. 2 in. (7.6 m). Front to rear spread is the same.

Outrigger Floats:

30 in. (762 mm) in diameter with storage on carrier.

Front Axle:

Planetary drive/steer, rigid mounted.

Rear Axle:

Planetary drive/steer, mounted on oscillating cradle with hydraulic lockout cylinders. Oscillation is ± 5.5 in. (140 mm). Oscillation lockout override control. Drive disconnect for two-wheel drive operation.

Service Brakes:

Dual circuit, full air operating drum brakes at each wheel.

Parking Brakes:

Spring set/air released drum brakes at each wheel.

(continued on back)

**Steering:**

Hydrostatic power steering, front and rear axles. Control modes for front only, four-wheel crab and crab steering, all controlled by the steering wheel. Switch for independent rear steer. Minimum turning radius is 24 ft. 8 in. (7.5 m).

Tires:

29.5x25-28PR tubeless with rock tread (E-3).

Tire Options:

29.5x29-34PR tubeless with rock tread (E-3).

33.25x29-26PR tubeless with rock tread (E-3).

Spare tires with rims.

Tire inflation kit.

Tire and rim removal device.

ENGINE

Cummins 6CTA8.3, 4-cycle, turbo-charged and aftercooled diesel with a displacement of 505 cu. in. (8.3 liters). Output is 250 HP (187 kw) @ 2,500 rpm with maximum torque of 650 ft. lbs. (881 Nm) @ 1,800 rpm.

ENGINE OPTION

Detroit Diesel 6V53T, 2-cycle, turbo-charged and aftercooled diesel with a displacement of 318 cu. in. (5.2 liters). Output is 250 HP (187 kw) @ 2,500 rpm with maximum torque of 593 ft. lbs. (804 Nm) @ 1,600 rpm.

Electrical:

24 volt system with negative ground, two 8D batteries, and a 70 amp alternator.

Fuel Tank:

80 gallon (303 liter) capacity.

TRANSMISSION

Powershift with hi/lo range and torque convertor, eight speeds forward, six reverse.

Max Speed:

24 mph (39 km/h).

Max Grade:

97% @ stall.

Miscellaneous Equipment (Standard):

Sliding engine hood, front and rear tow lugs, automatic moisture ejector, air dryer, headlights, taillights, turn signals and flashers, back-up alarm, rearview mirrors, storage compartments, and hook block tie down (D hook).

Miscellaneous Equipment (Optional):

Engine starting aid, pintle hooks, floodlights, amber beacon, roof wiper, hydraulic air conditioner, and choice of propane, diesel, or hydraulic (c/w AC) heater.

PCSA Rating Class 8-404

Capacity charts and related lifting data can be found in a separate publication.

RT 190 WEIGHT DISTRIBUTION	POUNDS			KILOGRAMS		
	GROSS	FRONT	REAR	GROSS	FRONT	REAR
Basic Machine	110,644	51,205	59,439	50188	23226	26962
Reductions for Transport						
Removable Counterweight	-17,500	9,545	-27,045	-7938	4330	-12268
29.5x25 Standard Tires	-6,887	-3,444	-3,443	-3124	-1562	-1562
Additions for Options						
Lattice Extension	1,477	2,507	-1,030	670	1137	-467
Telescopic Lattice Extension	3,053	5,182	-2,129	1385	2351	-966
Lattice Extender Insert	772	1,310	-538	350	594	-244
Auxiliary Boom Point	148	216	-68	67	98	-31
Auxiliary Winch Wire Rope	642	-374	1,016	291	-170	461
90 Ton Hook Block (travel)	1,226	2,104	-878	556	954	-398
20 Ton Hook Block (travel)	580	995	-415	263	451	-188
15 Ton Headache Ball (boom)	467	802	-335	212	364	-152
Detroit Diesel 6V53T Engine	273	235	38	124	107	17
29.5x29 Tires	1,080	540	540	490	245	245
33.25x29 Tires	1,777	889	888	806	403	403

3295J9

NOTE: All designs, specifications, and components of the equipment described are subject to change at the manufacturer's sole discretion at any time and without advance notice. Capacity charts and information printed here are only a guide and may not be complete. They should not be relied upon to operate the crane. The individual load charts and related lifting data on each crane must be understood and govern operation of the crane. Data published herein is informational in nature and shall not be construed to warrant suitability of the machine for any particular purpose as performance may vary with conditions encountered. The only warranty applicable is our standard warranty for this machine.

TEREX CRANES, INC.

P.O. Box 260002 Hwy. 501 East/Atlantic Center Conway, SC 29526-2602 U.S.A.
(803) 349-6900 FAX (803) 349-7090

P&H is a registered trademark of Harnischfeger Corporation.

RT190SPEC-1



495 Printed in US