

****Preliminary****

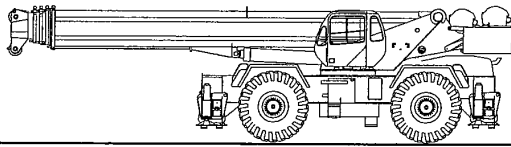

TEREX RT 1100 SERIES

rough terrain crane
specification



STANDARD BOOM EQUIPMENT

BOOM

41-155 ft. (12.52-47.24 m), five section, three mode, full power boom. Telescoping is electronically synchronized with single lever control. The extension system consists of one 2-stage telescope cylinder and one single stage telescope cylinder with wire rope used to extend and retract the tip section. The boom is a high-strength ovaloid design, with anti-friction slide pads. Boom plates are made of high strength steel to reduce weight and increase strength. A single boom hoist cylinder provides for boom elevation of -3 to 80 degrees. Maximum tip height 164 ft (50.00 m).

BOOM HEAD

Welded to fifth section of boom. Five nylon load sheaves and two idler sheaves mounted on heavy duty, anti-friction bearings. Quick reeving boom head. A supplied removable mount allows the addition of the sixth and seventh load sheaves for heavy lifts. Provisions included for side-stow jib mounting.

OPTIONAL BOOM EQUIPMENT

JIBS

30 ft. (9.13 m) side stow swing-on one-piece lattice type jib. Single nylon sheave mounted on anti-friction bearing. Jib is offsettable at 0°, 20°, or 40°. Maximum tip height is 193 ft. (58.83 m).

30-56 ft. (9.13-17.00 m) side stow bi-fold lattice type jib. Single nylon sheave mounted on anti-friction bearing. Jib is extendible to 56 ft. (17.00 m) by means of a swing-on extension. Extension remains stowed on side of boom when not in use. Jib is offsettable at 0°, 20°, or 40°. Maximum tip height is 219 ft. (66.75 m).

Two 26 ft. (7.92 m) inserts are available to extend the maximum jib length to 108 ft. (32.92 m). Inserts do not stow on crane. Maximum tip height is 271 ft. (82.6 m)

RUNNER

5 ft (1.5 m) runner is equipped with two nylon sheaves mounted on anti-friction bearings. Installs in place of jib. High offset and dual load sheaves provides high lift capacities with greater offset than available from main boom head alone. Can be used simultaneously with main winch reeved over main boom head.

AUXILIARY BOOM HEAD

Removable auxiliary boom head has single nylon sheave mounted on anti-friction bearing. Removable pin-type rope guard for quick reeving. Installs on main boom head only.

HOOK BLOCK

Seven metallic sheaves on anti-friction bearings with hook and hook latch. Quick reeving design does not require removal of wedge and socket from rope.

HOOK & BALL

12 ton (10.9 mt) top swivel ball with hook and hook latch.

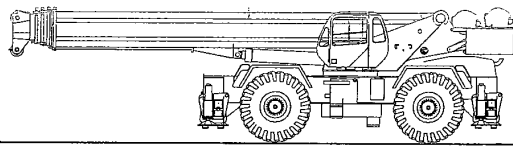

STANDARD UPPERSTRUCTURE EQUIPMENT

UPPERSTRUCTURE FRAME

All welded one-piece structure fabricated with high tensile strength alloy steel. Counterweight is pins to frame and is hydraulically installed and removed.

TURNTABLE CONNECTION

Swing bearing is a single row, ball type, with internal teeth. The swing bearing is bolted to the revolving upperstructure and to the carrier frame.

SWING

Hydraulic motors drive dual double planetary reduction swing reducers for precise and smooth swing function. Swing speed (no load) is 1.5 rpm.

SWING BRAKE

Spring set hydraulically released swing parking brakes. Hydraulic foot controlled momentary swing brakes. A 360° mechanical house lock is standard.

RATED CAPACITY INDICATOR

Rated Capacity Indicator with visual and audible warning system and automatic function disconnects. Second generation pictographic display includes: boom radius, boom angle, boom length, allowable load, actual load, and percentage of allowable load registered by bar graph. Operator settable alarms provided for swing angle, boom length, boom angle, tip height, and work area exclusion zone. Anti-two block system includes audio/visual warning and automatic function disconnects.

OPERATOR'S CAB

Environmental cab with all steel construction, optimum visibility, tinted safety glass throughout, and rubber floor matting is mounted on vibration absorbing pads. The cab has a sliding door on the left side, framed sliding window on the right side, hinged tinted all glass skylight and removable front windshield to provide optimum visibility of the load open or closed. Hot air defroster keeps windshield clear. Acoustical foam padding insulates against sound and weather. The deluxe six-way adjustable seat is equipped with a mechanical suspension and includes head and arm rests.

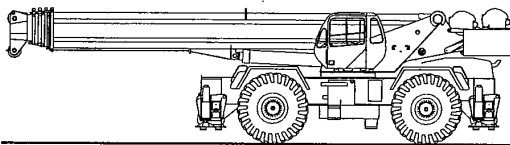

STANDARD CARRIER EQUIPMENT

CARRIER CHASSIS

Chassis is Terex designed with four-wheel drive and four-wheel steer (4X4X4). Has box-type construction with reinforcing cross members, a precision machined turn table mounting plate and integrally welded outrigger boxes. Decking has anti-skid surfaces, including between the frame rails, a lockable front tool storage compartment, and access steps and handles on the left and right sides and on all four corners. Lights are recessed into the outrigger boxes for protection. Air reservoir drains are collected in an easily accessible central location.

AXLES AND SUSPENSION

Rear axle is a planetary drive/steer type with 10.0 in (0.25m) of total oscillation. Automatic oscillation lockouts engage when the superstructure is swung 10° in either direction. Front axle is a planetary drive/steer type, rigidly mounted to the frame for increased stability.

CONTROLS

Armrest mounted dual axis controls for winch(s), swing, and boom elevation. Winch rotation indication incorporated into control handles. Armrest swings up to improve access and egress. Vernier adjustable hand throttle included. Steering column mounted turn signal, wiper, and shift controls. Switches include ignition, engine stop, lights, horn, roof window wiper, defroster, steering mode, parking brake, outriggers, 360° house lock, etc. Horn and winch speed shift switches are mounted in the levers. Foot control pedals include swing brake, boom telescope, service brake, and accelerator.

INSTRUMENTATION AND ACCESSORIES

In-cab gauges include air pressure, bubble level, engine oil pressure, fuel, engine temperature, voltmeter, transmission temperature, and transmission oil pressure. Indicators include low air, high water temperature, low oil pressure, high transmission temperature, and low coolant level audio/visual warning, hoist drum rotation indicator(s), and Rated Capacity Indicator. Accessories include fire extinguisher; light package including headlights, tail light, brake lights, directional signals, four-way hazard flashers, dome light, and back-up lights with audible back-up alarm; windshield washer/wiper; skylight wiper; R.H. and L.H. rear view mirrors; dash lights; and seat belt. Circuit breakers protect electrical circuits.

HYDRAULIC CONTROL VALVES

Valves are mounted on the rear of the upperstructure and are easily accessible. Valves have electric/hydraulic operators and include one pressure compensated four spool valve for boom elevation and telescope. One pressure compensated two spool valve for main and auxiliary winch, and one single spool valve for swing. System provides for simultaneous operation of all crane functions. Quick disconnects are provided for ease of installation of pressure check gauges.

OPTIONAL EQUIPMENT

Auxiliary Winch • Single axis armrest mounted controllers • LP Heater/Defroster • Hydraulically powered Air Conditioner with or without hydraulic heater • Work Lights • Rotating Beacon

STEERING

Hydraulic four-wheel full power steering for two-wheel, four-wheel coordinated, or four-wheel crab steer is easily controlled by steering wheel. A rear axle centering light is provided.

	Turning radius (to ϕ of outside tire.)	Curb clearance Radius
Two-wheel:	48' 3.5" (14.7 m)	50' 1.25" (15.27 m)
Four-wheel:	26' 3.25" (8.00 m)	28' 2.62" (8.60 m)

TRANSMISSION

Full power shift transmission with integral torque converter provides 6 speeds forward and 3 speeds reverse with neutral safety start. Four wheel drive engages only with first two gears and two wheel drive is available in all gears. A remote mounted oil filter provides easy access. Automatic pulsating back-up alarm.



STANDARD CARRIER EQUIPMENT (continued)

MULTI-POSITION OUT & DOWN OUTRIGGERS

Fully independent hydraulic outriggers may be utilized fully extended to 26 ft. (7.92 m) centerline to centerline, in their 1/2 extended position, or fully retracted for maximum flexibility. Easily removable 24" diameter Almag floats, each with an area of 452 in² (2916 cm²), stow on the outrigger boxes at their point of use. Complete controls and a sight leveling bubble are located in the operator's cab.

WHEELS & TIRES

Disc type wheels with full tapered bead seat rim. 180.0 in (4 572 mm) wheelbase.

TIRES

Wide earthmover (E3) style tread tires provide life and flotation. 33.25x29-32 PR std, 29.50x29- 34 PR opt.

SERVICE BRAKES

Split system air over hydraulic 18.5" (470 mm) diameter disc dual caliper brakes on all wheels.

PARKING BRAKE

Electrically controlled front axle mounted spring-set, air released drum type parking brake with indicator light.

OPTIONAL EQUIPMENT

Immersion Heater • Pintle Hook • Clearance Lights • Independent Rear Wheel Steer • Four Mode Rear Wheel Steer • 20,000 lb line pull front mounted winch

HYDRAULIC SYSTEM

HYDRAULIC PUMPS

Three single gear type pumps. Combined system capability is 156 gpm (592 lpm). Includes pump disconnect on winch and boom pumps.

Main and Auxiliary Winch Pump

66.6 gpm (252.1 lpm) @ 4,500 psi (316.4 kg/cm²)

Boom Hoist, Telescope Pump

66.6 gpm (252.1 lpm) @ 4,500 psi (316.4 kg/cm²)

Power Steering, Outrigger and Swing Pump

23.1 gpm (87.4 lpm) @ 3,500 psi (246.1 kg/cm²)

FILTRATION

Full flow oil filtration system with bypass protection includes a removable 60 mesh (250 micron) suction screen-type filter and two 5 micron synthetic depth type media replaceable return line filters.

HYDRAULIC RESERVOIR

All steel, welded construction with internal baffles and diffuser. Provides easy access to filters and is equipped with an external sight level gauge. The hydraulic tank is self pressurizing to aid in keeping out contaminants and in reducing potential pump cavitation. Capacity is 304 gal (1 151 liters). Hydraulic oil cooler is standard.

MAIN WINCH SPECIFICATION

Hydraulic winch with bent axis piston motor and planetary reduction gearing provides 2-speed operation with equal speeds for power up and down. Winch is equipped with an integral automatic brake, grooved drum, tapered flanges, standard cable roller on drum, and an electronic drum rotation indicator.

PERFORMANCE	LO-RANGE	HI-RANGE
Max. line speed (no load)		
First layer	199 fpm (60.6m/min)	328 fpm (100.0 m/min)
Fifth layer	274 fpm (83.5 m/min)	453 fpm (138.1 m/min)
Max. line pull-first layer	21,300 lbs (9 662 kg)	11,297 lbs (5 124 kg)
Max. line pull-fifth layer	15,454 lbs (7 010 kg)	8,180 lbs (3 710 kg)
Permissible line pull	16,800 lbs (7 530 kg)	

OPTIONAL AUX. WINCH

Hydraulic 2-speed winch with bent axis piston motor, equal speed power up and down, planetary reduction with integral automatic brake, grooved drum with tapered flanges, drum roller, and rotation indicator.

PERFORMANCE

Max. line speed (no load)
Fifth layer 453 fpm (138.1 m/min)
Max. line pull
First layer 21,300 lbs (9 662 kg)

DRUM DIMENSIONS AND CAPACITY (Same as main winch)

DRUM DIMENSIONS	DRUM CAPACITY
15.00 in (381 mm) drum diameter	Max. Storage: 1239 ft (377.6 m)
26.2 in (665 mm) length	Max. Useable: 1239 ft (377.6 m)*
26.5 in (673 mm) flange dia.	*Based on minimum flange height above
Cable: 3/4" x 850 ft (19 mm x 278.9 m)	top layer to comply with ANSI B30.5
Cable type: 3/4" (19mm) 35x7 rotation resistant compacted strand.	
Min breaking strength 42 tons (38.1 mt)	

OPTIONAL HOIST LINE

MAIN WINCH AND OPTIONAL AUXILIARY WINCH-3/4" (19mm) XIPS, IWRC Right Regular Lay. Min breaking strength 29.4 tons (26.7 mt).

ENGINE SPECIFICATIONS

Make and Model	Cummins QSC-300
Type	6 cylinder
Bore and Stroke	4.49 x 5.31 in (114x134.9 mm)
Displacement	506 cu in (8.3 l)
Rated HP	300 hp (224 kw) @ 2200 rpm
Maximum Gross HP	300 hp (224 kw) @ 2200 rpm
Maximum Gross Torque	1000 lb•ft (1 356 N•m) @ 1400 rpm
Aspiration	turbocharged & charge air cooled
Air Filter	dry type
Electrical System	12 volt
Alternator	130 amp
Battery	(2) 12V-1900 CCA
Fuel Capacity	80 gal (303 l)

PERFORMANCE (Standard Engine)

Transmission Gear	Forward Drive	Maximum Speed	Maximum Tractive Effort	Grade-ability @ Stall
1	4-wheel	1.6 mph (2.6 kph)	119,913 lbs (54 392 kg)	145.6%
2	4-wheel	2.3 mph (3.7 kph)	84,036 lbs (61 332 kg)	69.6%
3	2-wheel	4.4 mph (7.0 kph)	45,597 lbs (33 092 kg)	31.5%
4	2-wheel	6.2 mph (10.0 kph)	31,971 lbs (14 502 kg)	20.9%
5	2-wheel	14.3 mph (23.0 kph)	13,992 lbs (6 347 kg)	7.8%
6	2-wheel	20.4 mph (32.8 kph)	9,802 lbs (4 446 kg)	4.9%

All performance data is based on a gross vehicle weight of 142,000 lbs (64 410 kg), 32.25x29 tires, 4x4 drive. Performance may vary due to engine performance. Gradeability data is theoretical and is limited by tire slip, machine stability, or oil pan design.



GENERAL DIMENSIONS

NOTES:

- Dimensions given assume the boom is fully retracted in travel position and 33.23x29 tires.
- Minimum ground clearance under:
 - transmission - 29.00"
 - axle bowls - 26.50"
 - tie rods - 26.50"

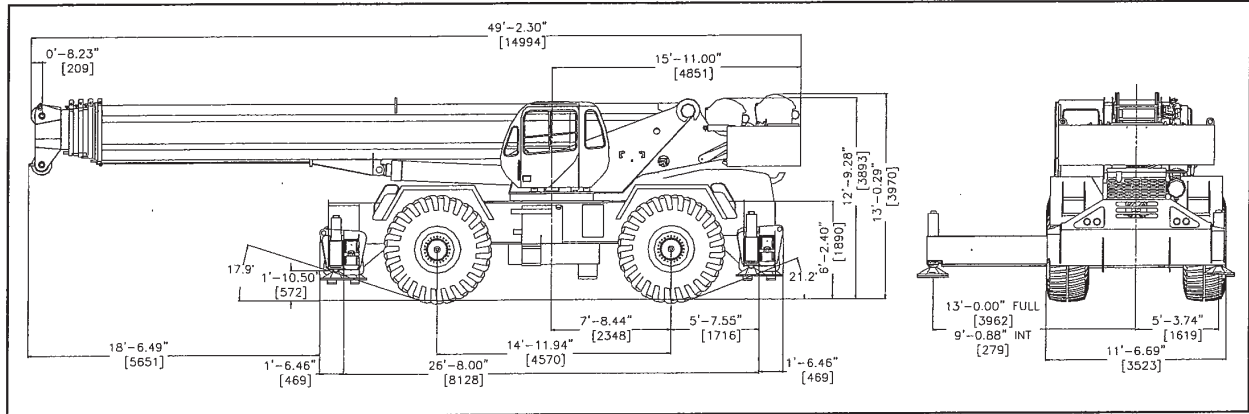

WEIGHTS & AXLE LOADS	GROSS WEIGHT LBS.	UPPER FACING FRONT		GROSS WEIGHT KG.	UPPER FACING FRONT	
		FRONT	REAR		FRONT	REAR
Basic Crane with no counterweight, full fuel tank, 6x19 rope, 33.25x29 32 PR tires	103,672	68,881	34,286	47021	31241	15551
Add 29,600 lb (13 426 kg) Counterweight	29600	-11725	41,325	13425	-5318	18743
Add Options:						
30' (9.13 m) Swing-on jib (Stowed)	+2,630	+4,594	-1,964	1193	2084	-891
30'-56' (9.13-17.0 m) Swing-on Jib (Stowed)	+3,640	+5,751	-2,111	1651	2608	-957
Auxiliary Boom Head	+170	+468	-298	77	212	-135
Auxiliary Winch with 850' of 6x19 class Wire Rope	+659	-253	912	299	-115	414
850' of Spin Resistant Rope (35x7) in lieu of 6x19 Main Winch	+221	-50	+271	100	-23	123
Aux Winch	+221	-97	+318	100	-44	144
130T (117.9 mt) 7-sheave Hook Block	+2,310	+3,889	-1,579	1048	1764	-716
100T (90.7 mt) 7-sheave Hook Block	+2,120	+3,569	-1,449	962	1619	-657
75T (68.0 mt) 5-Sheave Hook Block	+1,608	+2,707	-1,099	729	1228	-498
20T (18.1 mt) 1-Sheave Hook Block	+570	+960	-390	259	435	-177
12T (19.9 mt) Hook and Ball (In tool box)	+722	+749	-27	327	340	-12
Pintle Hook:						
Front	+45	+60	-15	20	27	-7
Rear	+45	-25	+70	20	-11	32
Substitute:						
29.5x29 34 PR Tires	-1776	-888	-888	-806	-403	-403

NOTE: Weights are for Terex supplied equipment and are subject to 2% variation due to manufacturing tolerances.

WE RESERVE THE RIGHT TO AMEND THESE SPECIFICATIONS AT ANY TIME WITHOUT NOTICE. THE ONLY WARRANTY APPLICABLE IS OUR STANDARD WRITTEN WARRANTY APPLICABLE TO THE PARTICULAR PRODUCT AND SALE. WE MAKE NO OTHER WARRANTY, EXPRESSED OR IMPLIED.