



Grove Maniwoc National Crane Potain



# National Crane 1300H Series

## Product Guide



### Features

- All new design
- 33,52 m (110 ft) four-section boom
- 27,2 t (30 USt) rating
- Multi-position Easy Reach control panel

# Features

## Overload protection

All National Crane boom trucks are equipped with overload protection. A Load Moment Indicator (LMI) is standard on all Series 1300H machines with Work Area Definition System (WADS). The LMI display console is weatherproof and the LCD display is visible in full or low light. All crane load lifting values are displayed simultaneously.



## Easy Reach control station

The Easy Reach control station can be tilted to the right or left side of the crane as needed and can be stowed in the center position for transport. The single axis pilot operated crane controls allow smooth operation for each crane function.



## Boom

The 110 ft four-section boom is the longest in its size range. The longer boom allows the operator to perform more lifts without the use of a jib, reducing setup time and improving efficiency. A 69 ft four-section boom or a 100 ft four-section boom are also available.

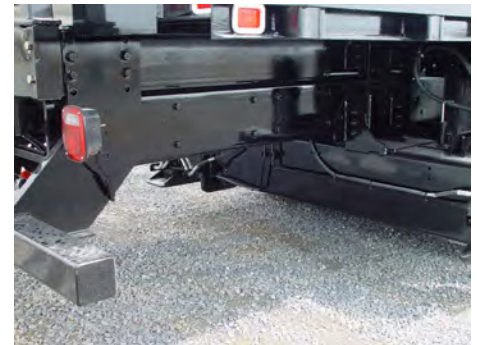

## Torsion box

The stronger standard torsion box improves rigidity, reduces truck frame flex and reduces the need for counterweight.

## Outriggers

Two sets of "HO"-style outriggers with 6 m (20 ft) full span, a 4,2 m (14 ft) mid span setting with manual locks and reduced capacity chart and fully retracted outrigger spread with reduced capacity chart. Main outriggers are equipped with removable ball and socket aluminum foot pads. Independent outrigger controls (umbilical design) are located at the easy reach control console and includes level indicator (sight bubble).

## Best in class performance and serviceability

- The Series 1300H comes standard with 410° non-continuous rotation
- Adjustable swing speed also comes standard on the Series 1300H. A control knob located on the swing motor brake release valve can be easily adjusted to the crane operator's swing speed preference
- Speedy-reeve boom tip and sheave blocks simplify rigging changes by decreasing the time needed to change line reeving
- The burst of speed winch provides faster winch payout and pickup of unloaded cable
- Pre-painted components reduce the possibility of rust, improve serviceability and enhance the appearance of the machine
- Additional serviceability enhancements such as boom bearing grease access points, the reduction of internal boom parts and internal anti-two block wiring keep you working longer
- The state of the art control valve provides smoother operation and eliminates parts to improve serviceability and reduce repair costs



\* Product may be shown with optional equipment.



# Contents

Features	2
Mounting configuration	5
Specifications	6
Capacities	8
Dimensions	11
Accessories	12
Notes	13

# Mounting configuration

The mounting configuration is based on an 85% stability factor. If the bare truck weight requirements are not met, counterweight will be required. The complete unit must be installed on the truck in accordance with factory requirements. Since individual truck chassis vary, a test must be performed on the unit to verify actual stability after mounting and installing counterweight (if required). A summary of mounting and truck requirements are:

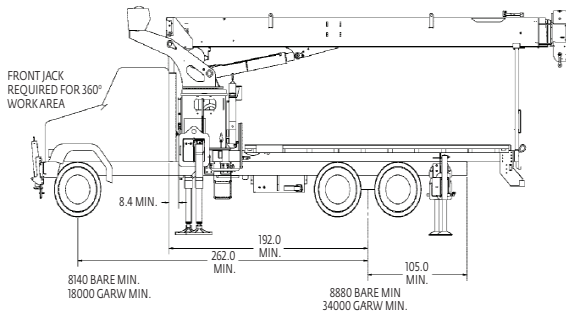

\*ALL DIMENSIONS INCHES AND POUNDS.

### For 180° working area –

- Gross Axle Weight Rating Front (GAWR) – 8165 kg (18,000 lb)
- Gross Axle Weight Rating Rear (GAWR) – 15 455 kg (34,000 lb)
- Gross Vehicle Weight Rating (GVW) – 23 587 kg (52,000 lb)
- Wheelbase (WB) – 6,65 m (262 in)
- Cab to Axle Trunnion (CT) – 4,88 m (192 in)
- After Frame (AF) – 2,67 m (105 in)
- Frame Section Modulus (SM) from outrigger to RSOD – 327 cm<sup>3</sup> (20 in<sup>3</sup>) and 759 MPa (110,000 psi) material
- Bare Chassis Weight required for stability prior to installation
  - Front – 3692 kg (8140 lb)
  - Rear – 4028 kg (8880 lb)

### For 360° working area –

- Optional Single Front Stabilizer (SFO)
- Gross Axle Weight Rating Front (GAWR) – 8165 kg (18,000 lb)
- Gross Axle Weight Rating Rear (GAWR) – 15 455 kg (34,000 lb)
- Gross Vehicle Weight Rating (GVW) – 23 587 kg (52,000 lb)
- Wheelbase (WB) – 6,65 m (262 in)
- Cab to Axle Trunnion (CT) – 4,88 m (192 in)
- After Frame (AF) – 2,67 m (105 in)
- Frame Section Modulus (SM) from front spring hanger to end of after frame – 327 cm<sup>3</sup> (30 in<sup>3</sup>) and 759 MPa (110,000 psi) material
- Bare Chassis Weight required for stability prior to installation
  - Front – 3720 kg (8200 lb)
  - Rear – 4037 kg (8900 lb)

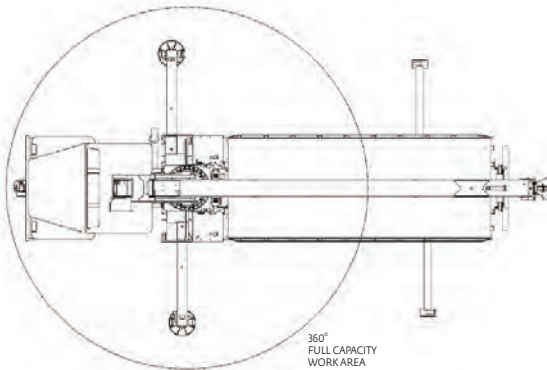

**Note:** Chassis will require extended front frame rails for SFO addition.

For 360° stability the truck frame must have a 492 cm<sup>3</sup> (30 in<sup>3</sup>) section modulus [372 850 Nm (3,300,000 in-lb) RBM] minimum under the crane frame, 295 cm<sup>3</sup> (18 in<sup>3</sup>) section modulus [223 710 Nm (1,980,000 in-lb) RBM] at the front spring rear hanger, 197 cm<sup>3</sup> (12 in<sup>3</sup>) section modulus [149 140 Nm (1,320,000 in-lb) RBM] through the front spring and 49 cm<sup>3</sup> (3 in<sup>3</sup>) section modulus [37 284 Nm (330,000 in-lb) RBM] at the stabilizer attachment point on each truck frame rail.

### Notes:

- Gross Vehicle Weight Rating (GVWR) is dependent on all components of the vehicle (axles, tires, springs, fame, etc.) meeting manufacturers' recommendations; always specify GVWR when purchasing trucks
- Diesel engines require a variable speed governor and energize-to-run fuel solenoid for smooth crane operation; electronic fuel injection is required
- All mounting data is based on a National Series 1300H with subbase and an 85% stability factor

- The complete unit must be installed in accordance with factory requirements, and a test performed to determine actual stability and counterweight requirements; contact the factory for details
- Transmission neutral safety interlock switch is required
- 13100H with front center stabilizer will be approximate 40 ft overall length. 13110H will exceed 40 ft overall length

THIS CHART IS ONLY A GUIDE AND SHOULD NOT BE USED TO OPERATE THE CRANE.



# Specifications

## Boom and jib combinations data

Available in three basic models:

**Model 1369H** – Equipped with a 6,7 m - 21,03 m (22 ft - 69 ft) four-section boom. Maximum tip height is 23,77 m (78 ft).

6,7 m - 21,03 m (22 ft - 69 ft) four-section boom.



**Model 13100H** – Equipped with a 8,83 m - 30,48 m (29 ft - 100 ft) four-section boom. This model can be equipped with a 7,62 m - 13,41 m (25 ft - 44 ft) two section jib. Maximum tip height with 13,41 m (44 ft) jib is 44,63 m (153 ft).

8,83 m - 30,48 m (29 ft -100 ft) four-section boom.

**13FJ44M** 7,62 m - 13,41 m (25 ft - 44 ft) two-section jib



**Model 13110H** – Equipped with a 10,05 m - 33,52 m (33 ft - 110 ft) four-section boom. This model can be equipped with a 7,62 m - 13,41 m (25 ft - 44 ft) two-section jib. Maximum tip height with 13,41 m (44 ft) jib is 49,68 m (163 ft).

10,05 m - 33,52 m (33 ft - 110 ft) four-section boom.

**13FJ44M** 7,62 m - 13,41 m (25 ft - 44 ft) two-section jib









**Note:** Maximum tip height is measured with outriggers/stabilizers fully extended.

# Specifications

## 1300H winch data

- Do not deadhead line block against boom tip when extending boom
- Keep at least three wraps of loadline on drum at all times
- Use only 9/16 in diameter rotation-resistant cable with 38,500 lb breaking strength on this machine

MAXIMUM BOOM LENGTH AT MAXIMUM ELEVATION WITH RIGGING SHOWN WITH LOAD BLOCK AT GROUND LEVEL

	1 part line	2 part line	3 part line	4 part line	5 part line	6 part line	7 part line
							
69 ft boom	69 ft	69 ft	69 ft	61 ft	51 ft	31 ft	21 ft
144 ft boom jib	100 ft	86 ft	58 ft	44 ft	44 ft	29 ft	
154 ft boom jib	110 ft	78 ft	62 ft	46 ft	46 ft	32 ft	

Winch	Average cable supplied	Breaking strength	Lift and speed	Lift and speed	Lift and speed	Lift and speed	Lift and speed	Lift and speed	Lift and speed
Standard planetary winch	9/16 in Diameter rotation resistant	17 464 kg (38,500 lb)	3493 kg (7700 lb) 50 m/min (164 fpm)	6986 kg (15,400 lb) 25 m/min (82 fpm)	10 478 kg (23,100 lb) 16 m/min (55 fpm)	13 971 kg (30,800 lb) 12 m/min (41 fpm)	17 464 kg (38,500 lb) 10 m/min (33 fpm)	20 956 kg (46,200 lb) 8 m/min (27 fpm)	24 449 kg (53,900 lb) 7 m/min (23 fpm)
"Burst of speed"	9/16 in Diameter rotation resistant	17 464 kg (38,500 lb)	1361 kg (3000 lb) 111 m/min (265 fpm)	2722 kg (6000 lb) 40 m/min (132 fpm)	4083 kg (9000 lb) 27 m/min (88 fpm)	5443 kg (12,000 lb) 20 m/min (66 fpm)	6804 kg (15,000 lb) 16 m/min (53 fpm)	8165 kg (18,000 lb) 13 m/min (44 fpm)	9526 kg (21,000 lb) 11 m/min (38 fpm)

All winch pulls and speeds in this chart are shown on the fourth layer. Winch line pulls would increase on the first, second and third layers. Winch line speed would decrease on the first, second and third layers. Winch line pulls may be limited by the winch capacity or the ANSI 5 to 1 cable safety factor. These are shown below:

Winch	4th layer drum pull	Allowable cable pull
Standard planetary	3493 kg (7700 lb) (low speed) 1361 kg (3000 lb) ("burst of speed")	3492 kg (7700 lb)

Block type	Rating	Weight
Downhaul weight	4,53 t (5 Ust)	68 kg (150 lb)
1 Sheave Block	10,89 t (12 Ust)	139 kg (305 lb)
2 Sheave Block	17,24 t (19 Ust)	159 kg (350 lb)
3 Sheave Block	27,22 t (30 Ust)	261 kg (575 lb)

THIS CHART IS ONLY A GUIDE AND SHOULD NOT BE USED TO OPERATE THE CRANE.

The individual crane's load chart, operating instructions and other instructional plates must be read and understood prior to operating the crane.

# Capacities

## Series 1369H: 21,03 m (69 ft) boom/full span outrigger and stabilizer

Other Series 1300H Load Rating Charts are available. National Crane will send you a chart on request – or you may secure needed load rating information through your nearest National Crane dealer.

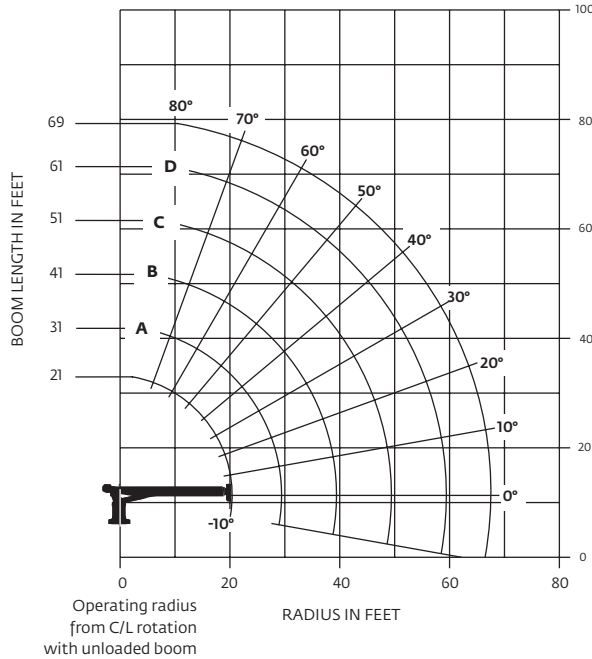

**CAUTION:**

- Do not operate crane booms, jib extensions, any accessories or loads within 3 m (10 ft) of live power lines or other conductors of electricity
- Jib and boom capacities shown are maximum for each section
- Do not exceed capacities at reduced radii
- Load ratings shown on the appropriate charts are maximum allowable loads with the crane mounted on a factory-approved truck and all outriggers at either full span or at mid span range and set on a firm level surface so that the crane is level and all tires are suspended
- Always level the crane with the level indicator located on the crane
- The operator must reduce load to allow for factors such as wind, ground conditions, operating speeds and their effects on freely suspended loads
- Overloading this crane may cause structural collapse or instability
- Weights on any accessories attached to the boom or loadline must be deducted from the load chart capacities
- Do not deadhead lineblock against boom tip when extending boom or winching up
- Keep at least three wraps of loadline on drum at all times
- Use only specified cable with this machine

**Notes:**

1. Operate with jib by radius when main boom is fully extended. If necessary increase boom angle to maintain loaded radius
2. Operate with jib by boom angle when main boom is not fully extended. Do not exceed rated jib capacities at any reduced boom lengths

### Load chart

LOADED RADIUS (ft)	LOADED BOOM ANGLE (deg)	21 ft BOOM (lb)	LOADED BOOM ANGLE (deg)	A 31 ft BOOM (lb)	LOADED BOOM ANGLE (deg)	B 41 ft BOOM (lb)	LOADED BOOM ANGLE (deg)	C 51 ft BOOM (lb)	LOADED BOOM ANGLE (deg)	D 61 ft BOOM (lb)	LOADED BOOM ANGLE (deg)	69 ft BOOM (lb)
5	71.6	*60,000										
8	62.5	47,500	71.7	33,500	76.9	33,400						
10	56	40,300	67.7	33,100	74	32,300	78.1	35,000				
12	49	34,900	63.6	32,700	71.2	31,100	75.7	30,100	78.9	29,000		
15	36.5	28,600	56.9	27,300	66.5	25,900	72	24,900	75.8	24,200	78.1	19,350
20			44.4	21,200	58.3	20,300	65.8	19,500	70.8	18,850	73.6	18,450
25			27.5	16,550	49.2	16,600	59.2	16,000	65.5	15,450	69	15,050
30					38.6	13,800	52.1	13,500	60	13,050	64.3	12,700
35					24	10,600	44.1	10,750	54	10,850	59.4	10,950
40							34.6	8650	47.6	8750	54.2	8950
45							23	7200	41	7300	48.6	7350
50									32.5	6050	43	6100
55									21.2	5100	36	5150
60											27.3	4350
65											13.7	3700
	0	15,000	0	10,000	0	7000	0	5000	0	3800	0	3625

**Notes:**

1. All capacities are in pounds, angles in degrees, and radii in feet
2. Loaded boom angles are given as reference only
3. Shaded areas are structurally limited capacities
4. Handling of personnel is only permitted with full span extension of all outrigger and stabilizer beams.
- \*5. See owners manuals. The 60,000 lb load requires optional 9/15 in diameter 6x25 IWRC cable

THIS CHART IS ONLY A GUIDE AND SHOULD NOT BE USED TO OPERATE THE CRANE.

The individual crane's load chart, operating instructions and other instructional plates must be read and understood prior to operating the crane.





# Capacities

## Series 13100H: 8,99 m - 30,48 m (25 ft - 44 ft) jib/full span outrigger and stabilizer

Other Series 1300H Load Rating Charts are available. National Crane will send you a chart on request – or you may secure needed load rating information through your nearest National Crane dealer.

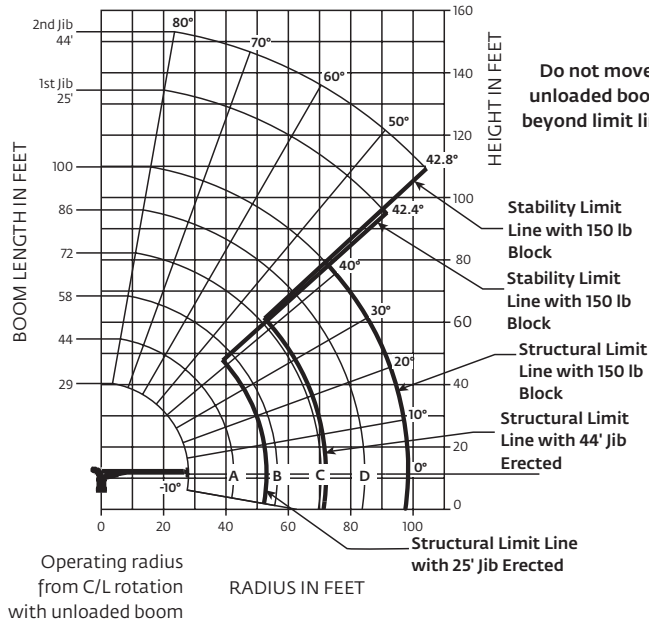

### CAUTION:

- Do not operate crane booms, jib extensions, any accessories or loads within 3 m (10 ft) of live power lines or other conductors of electricity
- Jib and boom capacities shown are maximum for each section
- Do not exceed capacities at reduced radii
- Load ratings shown on the load rating charts are maximum allowable loads with the outriggers properly extended and the outrigger lock pins engaged on a firm, level surface and the crane leveled and mounted on a factory recommended truck
- Always level the crane with the level indicator located on the crane
- The operator must reduce load to allow for factors such as wind, ground conditions, operating speeds and their effects on freely suspended loads
- Overloading this crane may cause structural collapse or instability
- Weights on any accessories attached to the boom or loadline must be deducted from the load chart capacities
- Do not deadhead lineblock against boom tip when extending boom or winching up
- Keep at least three wraps of loadline on drum at all times
- Use only specified cable with this machine

### Notes:

- Operate with jib by radius when main boom is fully extended. If necessary increase boom angle to maintain loaded radius
- Operate with jib by boom angle when main boom is not fully extended. Do not exceed rated jib capacities at any reduced boom lengths

## Load chart

### 29 ft – 100 ft BOOM RATED LOADS WITHOUT JIB

LOADED RADIUS (ft)	LOADED BOOM ANGLE (deg)	29 ft BOOM (lb)	LOADED BOOM ANGLE (deg)	A 44 ft BOOM (lb)	LOADED BOOM ANGLE (deg)	B 58 ft BOOM (lb)	LOADED BOOM ANGLE (deg)	C 72 ft BOOM (lb)	LOADED BOOM ANGLE (deg)	D 86 ft BOOM (lb)	LOADED BOOM ANGLE (deg)	100 ft BOOM (lb)	
5	77.3	*60,000											
8	70.8	44,000	77.9	29,100									
10	66.4	36,900	75.3	29,000									
12	61.8	33,450	72.7	28,600	78	28,600							
15	54.5	28,300	68.4	24,600	74.8	23,500	79	22,900					
20	40.6	21,950	60.9	21,000	69.4	19,000	74.6	17,450	78.3	16,300	79.9	10,650	
25	19.9	15,700	52.7	17,500	63.8	16,500	70.3	15,700	74.8	13,700	77.3	10,450	
30			43.5	12,800	57.9	13,200	65.8	13,500	71	11,350	74.4	10,000	
35			32.2	10,150	51.6	10,100	61.1	10,400	67.3	10,600	71.8	9400	
40			16.3	7850	45	8000	56.6	8250	63.8	8450	68.9	8050	
45					37	6500	51.3	6700	59.6	6900	65.6	7100	
50					26.9	5250	45.5	5500	55.3	5650	62	5850	
55							39.1	4500	50.8	4700	58.2	4850	
60								31.7	3700	45.9	3800	54.4	4000
65								22.1	3050	40.6	3150	50.5	3300
70									34.7	2600	46.3	2750	
75									27.7	2100	41.8	2250	
80									18.2	1700	36.8	1800	
85											31.2	1450	
90											24.4	1150	
95											14.6	900	
0		10,000	0	7600	0	4350	0	2600	0	1550	0	800	

### 25 ft – 44 ft JIB RATED LOADS

LOADED RADIUS (ft)	LOADED BOOM ANGLE (deg)	25 ft JIB (lb)	LOADED BOOM ANGLE (deg)	44 ft JIB (lb)
35	77.9	4900		
40	76.5	4500		
45	73.7	4050	75.9	2500
50	71.2	3700	74.3	2500
55	68.7	3400	72.4	2500
60	66.2	3150	70.2	2300
65	63.7	3000	68.1	2200
70	60.7	2700	66	2100
75	57.5	2250	63.8	2000
80	53.9	1800	61.3	1850
85	50.2	1350	59	1800
90	46.2	1000	56	1500
95	42.4	700	52.8	1200
100			49.5	900
105			46	600
110			42.8	500

### RATED LOAD REDUCTIONS WITH STOWED JIB

BOOM LENGTH (ft)	25 ft – 44 ft JIB STOWED
29	Reduce load 800 lb
44	Reduce load 600 lb
58	Reduce load 450 lb
72	Reduce load 350 lb
86	Reduce load 300 lb
100	Reduce load 250 lb

### Notes:

- All capacities are in pounds, angles in degrees, and radii in feet
- Loaded boom angles are given as reference only
- Shaded areas are structurally limited capacities
- Handling of personnel is only permitted with full span extension of all outrigger and stabilizer beams.
- \*5. See owners manuals. The 60,000 lb load requires optional 9/15 in diameter 6x25 IWRC cable

THIS CHART IS ONLY A GUIDE AND SHOULD NOT BE USED TO OPERATE THE CRANE.

The individual crane's load chart, operating instructions and other instructional plates must be read and understood prior to operating the crane.

## Capacities

### Series 13110H: 9,75 m - 33,53m (25 ft - 44 ft) jib/full span outrigger and stabilizer

Other Series 1300H Load Rating Charts are available. National Crane will send you a chart on request - or you may secure needed load rating information through your nearest National Crane dealer.

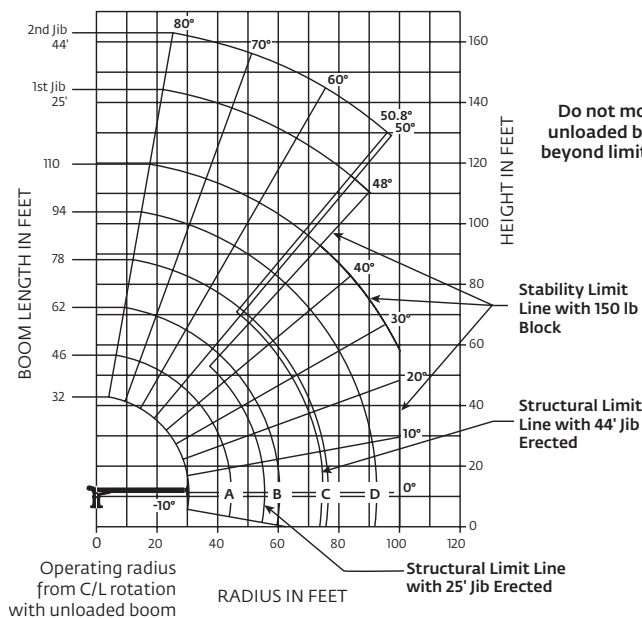

#### CAUTION:

- Do not operate crane booms, jib extensions, any accessories or loads within 3 m (10 ft) of live power lines or other conductors of electricity
- Jib and boom capacities shown are maximum for each section
- Do not exceed capacities at reduced radii
- Load ratings shown on the appropriate charts are maximum allowable loads with the crane mounted on a factory-approved truck and all outriggers at either full span or at mid span range and set on a firm level surface so that the crane is level and all tires are suspended
- Always level the crane with the level indicator located on the crane
- The operator must reduce load to allow for factors such as wind, ground conditions, operating speeds and their effects on freely suspended loads
- Overloading this crane may cause structural collapse or instability
- Weights on any accessories attached to the boom or loadline must be deducted from the load chart capacities
- Do not deadhead lineblock against boom tip when extending boom or winching up
- Keep at least three wraps of loadline on drum at all times
- Use only specified cable with this machine

#### Notes:

1. Operate with jib by radius when main boom is fully extended. If necessary increase boom angle to maintain loaded radius
2. Operate with jib by boom angle when main boom is not fully extended. Do not exceed rated jib capacities at any reduced boom lengths

### Load chart

#### 32 ft – 110 ft BOOM RATED LOADS WITHOUT JIB

LOADED RADIUS (ft)	LOADED BOOM ANGLE (deg)	32 ft BOOM (lb)	LOADED BOOM ANGLE (deg)	A 46 ft BOOM (lb)	LOADED BOOM ANGLE (deg)	B 62 ft BOOM (lb)	LOADED BOOM ANGLE (deg)	C 78 ft BOOM (lb)	LOADED BOOM ANGLE (deg)	D 94 ft BOOM (lb)	LOADED BOOM ANGLE (deg)	110 ft BOOM (lb)	
6	76.7	60,000											
8	72.5	43,000	78.6	29,100									
10	68.5	35,900	76.1	29,000									
12	64.4	32,000	73.6	28,000	78	28,000							
15	57.9	27,000	69.5	24,000	76.1	23,000	80	19,500					
20	45.9	19,500	62.5	18,300	71.1	17,500	76.4	17,500	80	16,300			
25	30.6	14,900	55	14,500	65.9	14,050	72.4	14,000	76.8	13,700	79.3	10,450	
30			46.3	12,000	60.8	11,600	68.2	11,500	73.4	11,350	76.5	9150	
35			36.2	9450	54.8	9800	64	9700	70.1	10,600	74.1	8950	
40			23.9	7250	48.5	8100	59.6	8300	66.7	8450	71.2	7700	
45					42	6550	55.4	7000	63.3	6900	68.7	6950	
50					34	5300	50.4	5550	59.4	5650	65.6	5900	
55						23.8	4300	45	4550	55.4	4700	62.3	4900
60								39	3700	51.3	3800	58.9	4000
65								32.1	3000	46.8	3100	55.4	3300
70								23.5	2350	42.1	2550	51.8	2700
75									36.9	2050	48.1	2200	
80									30.9	1650	44.2	1750	
85									23.4	1250	39.9	1400	
90									11.9	900	35.2	1050	
95											29.9	750	
100											23.4	500	
0		8000	0	4800	0	2600	0	1200	0	850			

#### 25 ft – 44 ft JIB RATED LOADS

LOADED RADIUS (ft)	LOADED BOOM ANGLE (deg)	25 ft JIB (lb)	LOADED BOOM ANGLE (deg)	44 ft JIB (lb)
40	77.4	4400		
45	75.8	4400	76.7	2700
50	73.6	4100	75.1	2650
55	69.5	1900	73.2	2500
60	66.6	1450	71.1	2300
65	63.8	1000	69.2	1250
70	60.8	600	64.5	750
75			61.7	500
80				

#### RATED LOAD REDUCTIONS WITH STOWED JIB

BOOM LENGTH (ft)	25 ft – 44 ft JIB STOWED
32	Reduce load 800 lb
46	Reduce load 600 lb
62	Reduce load 450 lb
78	Reduce load 350 lb
94	Reduce load 300 lb
110	Reduce load 250 lb

#### Notes:

1. All capacities are in pounds, angles in degrees, and radii in feet
2. Loaded boom angles are given as reference only
3. Shaded areas are structurally limited capacities
4. Handling of personnel is only permitted with full span extension of all outrigger and stabilizer beams.
- \*5. See owners manuals. The 60,000 lb load requires optional 9/15 in diameter 6x25 IWRC cable

THIS CHART IS ONLY A GUIDE AND SHOULD NOT BE USED TO OPERATE THE CRANE.

The individual crane's load chart, operating instructions and other instructional plates must be read and understood prior to operating the crane.



# Dimensions

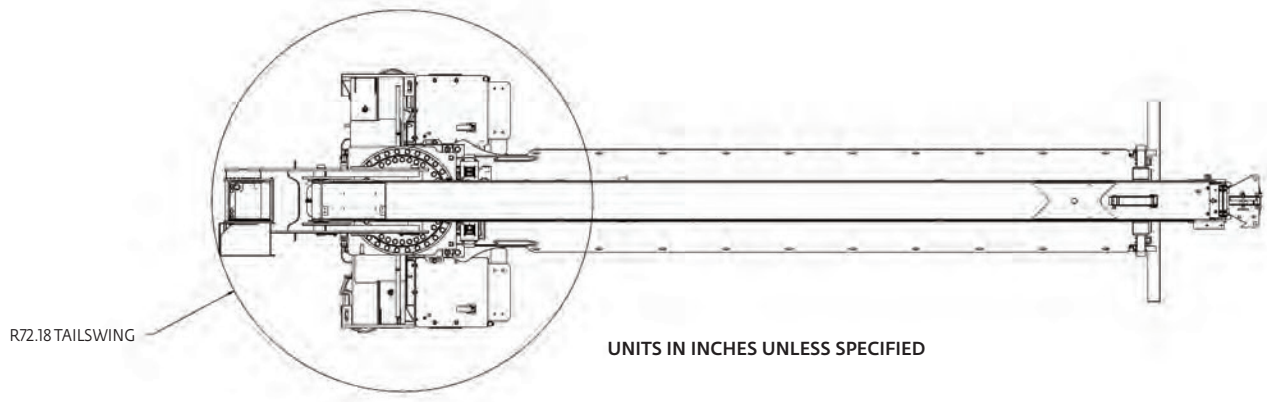

UNITS IN INCHES UNLESS SPECIFIED

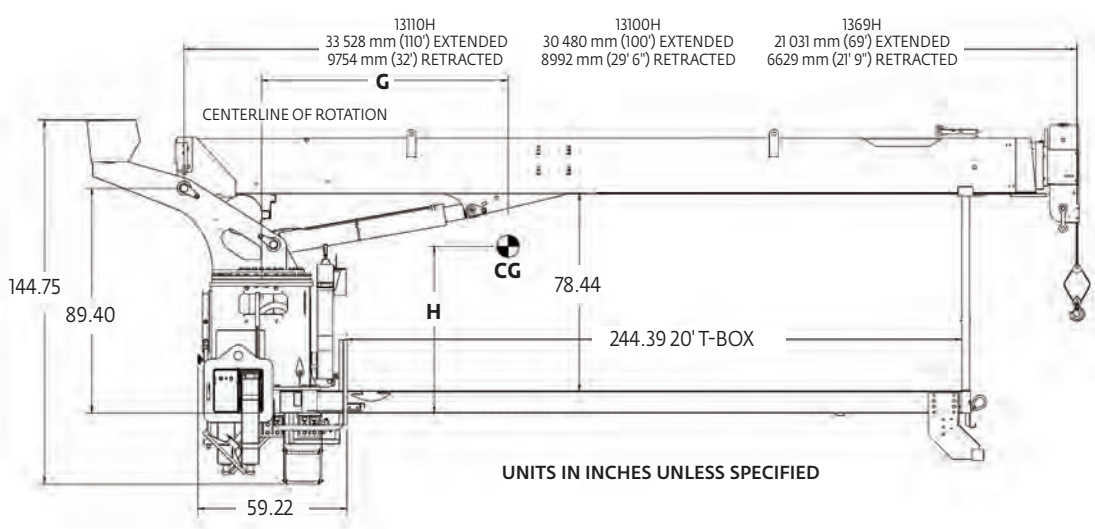

UNITS IN INCHES UNLESS SPECIFIED

G CENTER OF GRAVITY FROM CENTERLINE				
Series	G	H	Dry weight*	With oil weight*
1369H	155 cm (61.2 in)	152 cm (59.8 in)	8374 kg (18,462 lb)	8707 kg (19,196 lb)
13100H	226 cm (89.1 in)	163 cm (64.1 in)	9348 kg (20,608 lb)	9681 kg (21,342 lb)
13110H	251 cm (98.7 in)	166 cm (65.4 in)	9682 kg (21,346 lb)	10 015 kg (22,080 lb)

\* Above weights do not include reservoir, RSOD, jib, PTO, pump, BED.

\*\* Weight includes boom, winch, rope, turret, lift cylinder, frame, controls, outriggers, platforms, torque box, boom rest, bumper, downhaul weight.

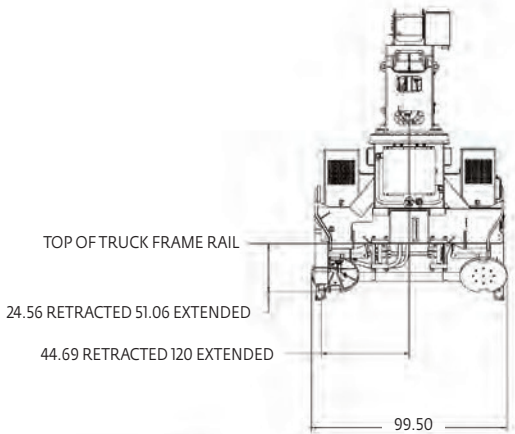

UNITS IN INCHES UNLESS SPECIFIED

THIS CHART IS ONLY A GUIDE AND SHOULD NOT BE USED TO OPERATE THE CRANE.

The individual crane's load chart, operating instructions and other instructional plates must be read and understood prior to operating the crane.



# Accessories

**Radio Remote Controls –**

Eliminate the handling and maintenance concerns that accompany cabled remotes. Operate to a range of about 76 m (250 ft), varying with conditions.

- NB4R

**One-Person Basket –**

Strong but lightweight steel basket with 139 kg (300 lb) capacity, gravity hung with swing lock and full body harness.

- B1-S
- 2B1-S (for dual locking baskets)

**Heavy-duty Personnel Basket –**

544 kg (1200 lb) capacity steel basket with safety loops for two passengers. Gravity leveling 183 cm x 107 cm (72 in x 42 in) platform. Fast attachment and secure locking systems. Load chart must show 1043 kg (2300 lb) minimum to operate this accessory.

- BSA-1
- BSA-R1 (provides rotation)

**Winch Drum Rotation Indicator**

- WDRI

**Last Wrap Indicator Option** on winch with indicator on Easy Reach console.

- LLI

**Single Front Outrigger**

Center front stabilizer with a 25 in vertical stroke

- SFO

**Steel Tool Box Options**

**Bulkhead-steel for super-duty beds**

- BHSD



# Notes



# Notes



Grove Manitowoc National Crane Potain



## Regional headquarters

### Manitowoc - Americas

Manitowoc, Wisconsin, USA

Tel: +1 920 684 6621

Fax: +1 920 683 6277

Shady Grove, Pennsylvania, USA

Tel: +1 717 597 8121

Fax: +1 717 597 4062

### Manitowoc - Europe, Middle East & Africa

Ecully, France

Tel: +33 (0)4 72 18 20 20

Fax: +33 (0)4 72 18 20 00

### Manitowoc - Asia Pacific

Shanghai, China

Tel: +86 21 6457 0066

Fax: +86 21 6457 4955

## Regional offices

### Americas

#### Brazil

Alphaville

#### Mexico

Monterrey

#### Chile

Santiago

### Europe, Middle East & Africa

#### Algeria

Hydra

#### Czech Republic

Netvorice

#### France

Baudemont

Cergy

Decines

#### Germany

Langenfeld

#### Hungary

Budapest

#### Italy

Parabiago

#### Netherlands

Breda

#### Poland

Warsaw

#### Portugal

Baltar

Lisbon

#### Russia

Moscow

#### U.A.E.

Dubai

#### U.K.

Gawcott

### Asia - Pacific

#### Australia

Brisbane

Melbourne

Sydney

#### China

Beijing

Xi'an

#### India

Hyderabad

Pune

#### Korea

Seoul

#### Philippines

Makati City

#### Singapore

## Factories

### Brazil

Alphaville

### China

TaiAn

Zhangjiagang

### France

Charlieu

La Clayette

Moulins

### Germany

Wilhelmshaven

### India

Pune

### Italy

Niella Tanaro

### Portugal

Baltar

Fânzeres

### Slovakia

Saris

### USA

Manitowoc

Port Washington

Shady Grove

This document is non-contractual. Constant improvement and engineering progress make it necessary that we reserve the right to make specification, equipment, and price changes without notice. Illustrations shown may include optional equipment and accessories and may not include all standard equipment.

