

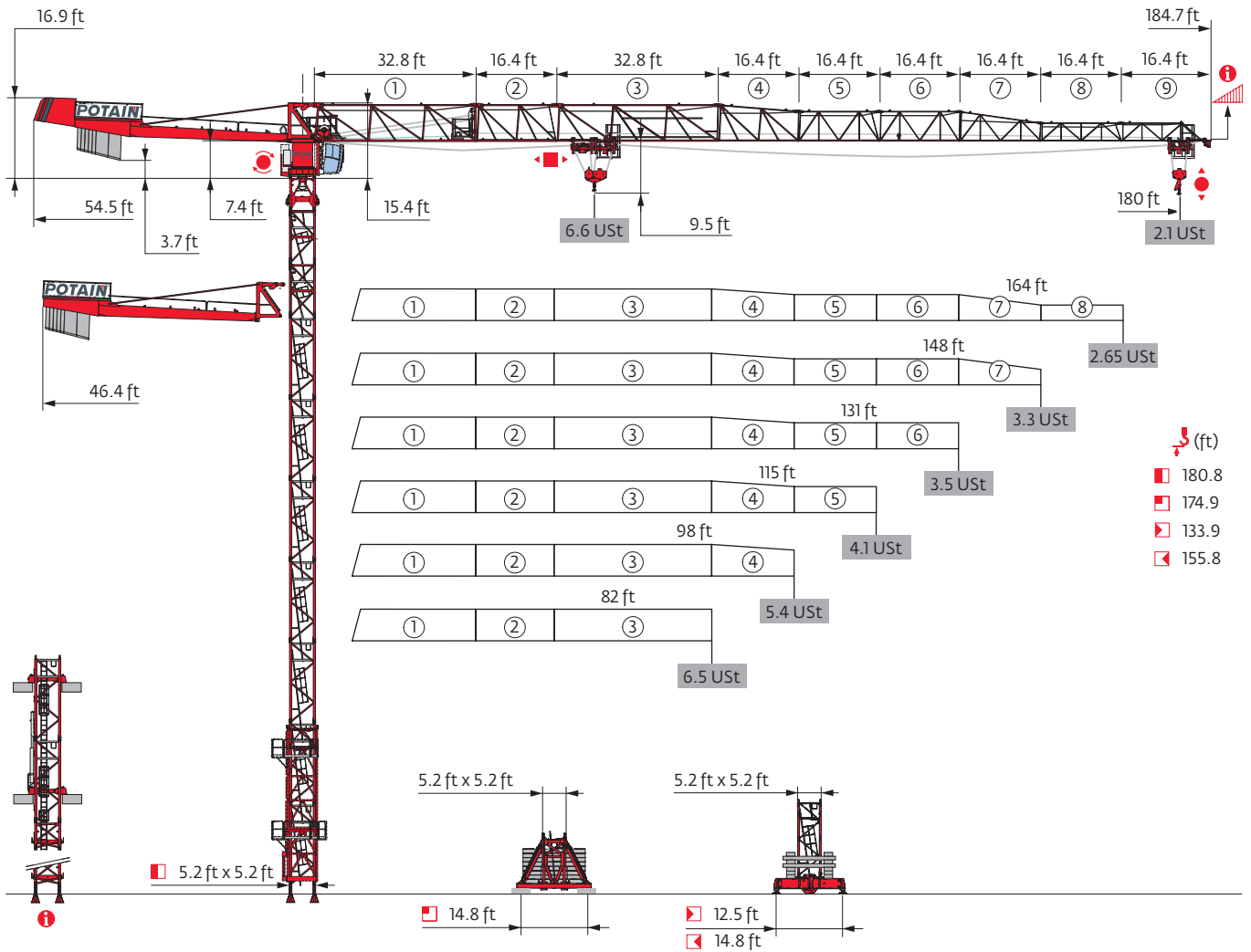

MDT 139



Potain Plus

Power Control

CraneSTAR

Top Site

Top Tracing 3

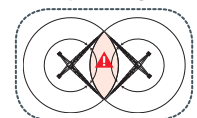
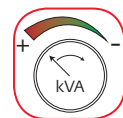



Mast - Reactions

5.2 ft City - P 41A							
MAST (ft)	82	98	115	131	148	164	180
↓ (ft)	179.5	179.5	179.5	179.5	168.6	168.6	168.6
↓/P+ (ft)	179.5	179.5	179.5	179.5	168.6	168.6	168.6
MAST	10.9 ft	0	0	0	2	2	2
	16.4 ft	11	11	11	9	9	9
F2 (Ust)	●	125	125	124	126	123	122
	■	189	189	195	196	176	175
F3 (Ust)	●	97	96	95	96	93	91
	■	165	164	170	169	149	147

5.2 ft City - ZC 4230							
MAST (ft)	82	98	115	131	148	164	180
↓ (ft)	128.6	133.9	133.9	133.9	128.6	123	123
↓/P+ (ft)	128.6	133.9	133.9	133.9	128.6	123	123
MAST	10.9 ft	1	0	0	0	1	2
	16.4 ft	7	8	8	8	7	6
F1 (Ust)	●	68	69	69	70	70	68
	■	65	67	71	71	67	67

5.2 ft City - ZD 4230							
MAST (ft)	82	98	115	131	148	164	180
↓ (ft)	155.8	155.8	155.8	155.8	150.3	150.3	150.3
↓/P+ (ft)	155.8	155.8	155.8	155.8	150.3	150.3	150.3
MAST	10.9 ft	2	2	2	2	0	0
	16.4 ft	8	8	8	8	9	9
F1 (Ust)	●	69	69	69	69	70	69
	■	81	80	84	85	75	78

5.2 ft - P 41A							
MAST (ft)	82	98	115	131	148	164	180
↓ (ft)	180.8	180.8	175.2	175.2	169.6	164.4	169.6
↓/P+ (ft)	180.8	180.8	175.2	175.2	169.6	164.4	169.6
MAST	6.6 ft	1	1	1	1	1	1
	10.9 ft	1	1	2	2	0	0
	16.4 ft	10	10	9	9	10	9
F2 (Ust)	●	131	131	126	128	128	123
	■	209	208	205	206	188	178
F3 (Ust)	●	99	98	94	94	94	89
	■	180	179	176	175	158	147

5.2 ft - S 41A							
MAST (ft)	82	98	115	131	148	164	180
↓ (ft)	174.9	174.9	169.3	174.9	174.9	169.3	174.9
↓/P+ (ft)	174.9	174.9	169.3	174.9	174.9	169.3	174.9
MAST	6.6 ft	1	1	1	1	1	1
	10.9 ft	1	1	2	1	1	2
	16.4 ft	9	9	8	9	9	8
F1 (Ust)	●	84	84	81	85	87	82
	■	111	111	109	115	113	106

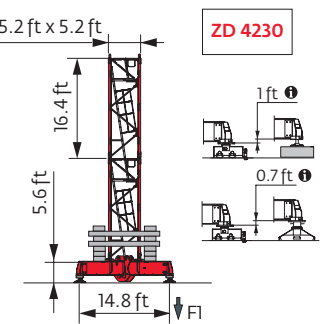
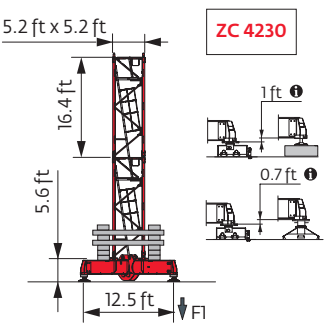
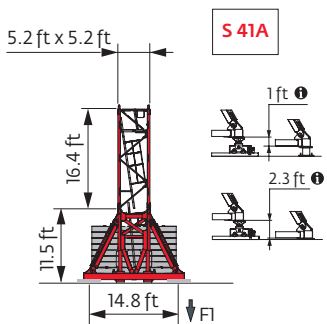
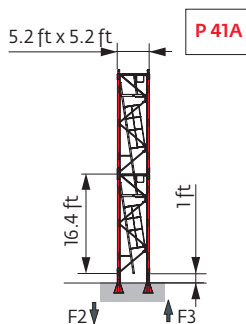

Note: When "ASCE" is noted in this data sheet it is referring to 115 mph Wind Zone, Exposure B, Design Wind Speed = 98 mph. See back cover for design wind speed calculations.



Anchorage



Base ballast

🏗️ (Ust) / 🏠 5.2 ft City - ZC 4230 - 🏗️							
🏗️ (ft)	82	98	115	131	148	164	180
133.9		88.2	88.2	88.2			
128.6	88.2	88.2	82.7	82.7	88.2		
123	82.7	82.7	77.2	77.2	82.7	88.2	88.2
106.6	71.7	71.7	66.1	66.1	71.7	71.7	71.7
90.2	71.7	71.7	66.1	66.1	66.1	66.1	66.1
73.8	71.7	71.7	66.1	66.1	66.1	66.1	66.1
57.4	71.7	71.7	66.1	66.1	66.1	66.1	66.1
41	71.7	71.7	66.1	66.1	66.1	66.1	66.1

🏗️ (Ust) / 🏠 5.2 ft City - ZD 4230 - 🏗️							
🏗️ (ft)	82	98	115	131	148	164	180
155.8	88.2	88.2	88.2	88.2			
150.3	82.7	82.7	77.2	77.2	88.2	88.2	88.2
133.9	66.1	66.1	66.1	66.1	71.7	71.7	71.7
117.5	55.1	55.1	49.6	55.1	60.6	60.6	60.6
101.1	55.1	49.6	49.6	44.1	44.1	44.1	44.1
84.7	55.1	49.6	49.6	44.1	44.1	44.1	44.1
68.2	55.1	49.6	49.6	44.1	44.1	44.1	44.1
51.8	55.1	49.6	49.6	44.1	44.1	44.1	44.1
35.4	55.1	49.6	49.6	44.1	44.1	44.1	44.1

🏗️ (Ust) / 🏠 5.2 ft - S 41A - 🏗️							
🏗️ (ft)	82	98	115	131	148	164	180
174.9	125.7	125.7		125.7	125.7		125.7
169.3	119.1	112.4	119.1	119.1	112.4	112.4	119.1
152.9	86	86	92.6	92.6	92.6	92.6	92.6
136.5	72.8	72.8	66.1	72.8	79.4	79.4	79.4
120.1	59.5	59.5	52.9	59.5	59.5	66.1	59.5
103.7	46.3	46.3	46.3	46.3	46.3	52.9	46.3
87.3	46.3	46.3	46.3	46.3	46.3	46.3	46.3
70.9	46.3	46.3	46.3	46.3	46.3	46.3	46.3
54.5	46.3	46.3	46.3	46.3	46.3	46.3	46.3
38.1	46.3	46.3	46.3	46.3	46.3	46.3	46.3



Load curves



(ft)		56	66	72	82	89	98	105	115	121	131	138	148	154	164	171	180	ft	
	6.6 USt																		
	3.3 USt																		
180	9 → 67	116 - 126	6.6	6.6	6	5.2	4.8	4.2	3.8	3.4	3.3	3.1	2.95	2.7	2.5	2.3	2.15	1.95	USt
	9 → 68	118 - 130	6.6	6.6	6.2	5.3	4.8	4.2	3.9	3.4	3.3	3.3	3.1	2.8	2.65	2.45	2.3	2.1	USt P+
164	9 → 73	123 - 135	6.6	6.6	6.6	5.7	5.1	4.5	4.1	3.6	3.4	3.3	3.2	2.95	2.8	2.55	USt		
	9 → 74	127 - 138	6.6	6.6	6.6	5.8	5.3	4.6	4.2	3.8	3.5	3.3	3.3	3.1	2.9	2.65	USt P+		
148	9 → 71	126 - 140	6.6	6.6	6.4	5.6	5.1	4.5	4.2	3.7	3.5	3.3	3.3	3.1	USt				
	9 → 77	135 - 148	6.6	6.6	6.6	6.1	5.6	5	4.6	4.1	3.8	3.4	3.3	3.3	USt P+				
131	9 → 68	122 - 131	6.6	6.6	6.2	5.4	4.9	4.3	4	3.6	3.3	3.3 USt							
	9 → 74		6.6	6.6	6.6	5.9	5.4	4.8	4.4	3.9	3.7	3.3	USt P+						
115	9 → 68		6.6	6.6	6.2	5.4	4.9	4.3	4	3.6	USt								
	9 → 74		6.6	6.6	6.6	5.9	5.4	4.8	4.4	3.9	USt P+								
98	9 → 73		6.6	6.6	6.6	5.8	5.3	4.7	USt										
	9 → 80		6.6	6.6	6.6	6.4	5.9	5.2	USt P+										
82	9 → 72		6.6	6.6	6.6	5.7	USt												
	9 → 79		6.6	6.6	6.6	6.3	USt P+												

$$\text{Icon} = \text{Icon} - 0.42 \text{ USt max.}$$



(ft)		56	66	72	82	89	98	105	115	121	131	138	148	154	164	171	180	ft	
	6.6 USt																		
	3.3 USt																		
180	7 → 69	121 - 121	6.6	6.6	6.2	5.4	5	4.4	4	3.6	3.3	3	2.8	2.55	2.4	2.15	2.05	1.85	USt
	7 → 70	124 - 125	6.6	6.6	6.4	5.5	5	4.4	4.1	3.7	3.4	3.1	2.95	2.7	2.5	2.3	2.2	1.95	USt P+
164	7 → 75	128 - 131	6.6	6.6	6.6	5.9	5.3	4.7	4.3	3.8	3.6	3.3	3.1	2.8	2.65	2.45	USt		
	7 → 76	133 - 133	6.6	6.6	6.6	6	5.5	4.8	4.4	4	3.7	3.4	3.2	2.95	2.75	2.55	USt P+		
148	7 → 73	132 - 135	6.6	6.6	6.6	5.8	5.3	4.7	4.4	3.9	3.7	3.3	3.2	2.95	USt				
	7 → 79	141 - 142	6.6	6.6	6.6	6.4	5.8	5.2	4.8	4.3	4	3.6	3.4	3.2	USt P+				
131	7 → 70	128 - 131	6.6	6.6	6.4	5.6	5.1	4.5	4.2	3.8	3.5	3.3	3.3 USt						
	7 → 76		6.6	6.6	6.6	6.1	5.6	5	4.6	4.1	3.9	3.5	USt P+						
115	7 → 70		6.6	6.6	6.4	5.6	5.1	4.5	4.2	3.8	USt								
	7 → 76		6.6	6.6	6.6	6.1	5.6	5	4.6	4.1	USt P+								
98	7 → 75		6.6	6.6	6.6	6	5.5	4.9	USt										
	7 → 82		6.6	6.6	6.6	6.6	6.1	5.4	USt P+										
82	7 → 74		6.6	6.6	6.6	5.9	USt												
	7 → 81		6.6	6.6	6.6	6.5	USt P+												

$$\text{Icon} = \text{Icon} - 0.08 \text{ USt max.}$$

Jib weight & counter-jib ballast

	(lb) - 25 LVF (+/- 5%)					(lb)
				7,937 lb	2,425 lb	
180 ft	16,925	16,616	17,262	2	5	27,999
164 ft	16,495	16,186	16,832	2	5	27,999
148 ft	15,988	15,679	16,325	2	4	25,574
131 ft	15,338	15,029	15,675	2	3	23,149
115 ft	14,588	14,279	14,925	2	2	20,723
98 ft	13,986	13,678	14,323	2	2	20,723
82 ft	13,186	12,877	13,523	2	1	18,298

CAU - 7,937 lb

CAV - 2,425 lb

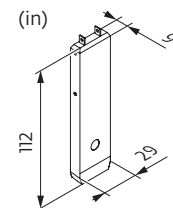
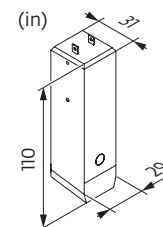









Dimensions and weight

Slewing crane part: 180 ft - - -

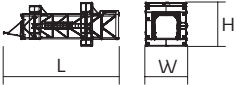

Slewing crane part		L (ft)	W (ft)	H (ft)	lb (+/- 5%)
Counter-jib		39	3.9	8.2	10,406
Towerhead + cab	Ultra View	14.2	7.4	8	11,890
Jib section	① 25 LVF 6 DVF	35.9	9.6	8.5	7,110
Jib section	② ⑤ ⑥ ⑧	17.2 17 17 16.9	3.4 3.4 3.4 3.4	7.7 6.3 6.2 3.9	1,620 886 756 503
Jib section	③	33.4	3.4	7.7	2,482
Jib section	④ ⑦	17 16.9	3.4 3.4	7.6 6.2	990 646
Jib section	⑨	17	3.4	3.8	417
Hoisting winch (+ rope)	25 LVF 33 LVF 50 LVF	4.3 4.5 5	2.3 3 3.1	2.3 2.9 3	1,687 2,127 3,075
Trolley	6.6 USt	5.2	4.4	2.9	617
Pulley block	6.6 USt	3	0.9	4.3	628
Trolley	6.6 USt	4.6	4.1	3.1	617
Trolley	6.6 USt 3.3 USt	4.7 5	4.1 4.3	3.1 3.1	617 518
Pulley block	6.6 USt 3.3 USt	4.1 2.6	0.9 0.7	5 4.2	551 287

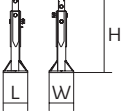

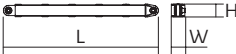
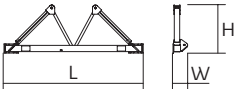
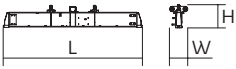
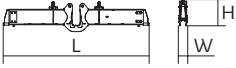
Crane tower		L (ft)	W (ft)	H (ft)	lb (+/- 5%)	
Telescopic cage		5.2 ft	36.8	13.1	11.7	14,220
K40/K40		5.2 ft	7.3	6.9	6.8	3,208
K 437B K 437E KM 437E KM 439E		5.2 ft	33.5 33.5 33.5 33.5	5.5 5.3 5.3 5.3	5.3 5.3 5.3 5.3	7,606 7,474 7,088 8,448
K 437A KMT 437A K 439A KMT 439A		5.2 ft	17.1 17.1 17.1 17.1	5.5 5.5 5.5 5.5	5.3 5.3 5.3 5.3	4,079 3,847 4,916 4,696
K 437C		5.2 ft	11.3	5.5	5.3	2,998
Fixing angles		P 41A	1.2	1.2	3.7	293
Basic mast unit		S 41A	11.9	6.4	6.8	6,537
Struts		S 41A	10.4	0.9	0.8	489
Half-bearer		S 41A	16.7	2	5.8	2,524
Cross girder		ZC 4230 ZD 4230	18.5 21.8	2.7 2.7	3.4 3.4	3,505 4,035
Cross girder		ZC 4230 ZD 4230	18.5 21.8	1.5 1.5	4.4 4.4	4,178 4,707



Mechanisms

480 V - 60 Hz											hp	kW	
	25 LVF 15 Optima	fpm	97	128	179	230	49	66	92	115	25	18	912 ft
		USt	3.3	2.5	1.7	0.8	6.6	5	3.3	1.8			
	33 LVF 15 Optima	fpm	118	154	221	315	59	79	116	157	33	22	1,001 ft
		USt	3.3	2.5	1.7	0.6	6.6	5	3.3	1.4			
	50 LVF 15 Optima	fpm	203	262	374	535	105	138	205	267	50	37	1,549 ft
		USt	3.3	2.5	1.7	0.8	6.6	5	3.3	1.9			
	6 DVF 4 Optima	fpm	0 → 262 (6.6 USt) 0 → 328 (2.2 USt)						5.5	4			
	RVF 152 Optima+	rpm	0 → 0.8						2 x 5.5	2 x 4			

IEC 60204-32		
480 V (+6% -10%) 60 Hz	25 LVF: 34 → 24 kVA	
	33 LVF: 41 → 28 kVA	
	50 LVF: 54 → 34 kVA	

25 LVF 15 Optima

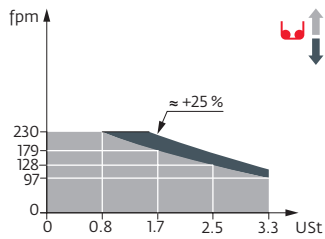

33 LVF 15 Optima

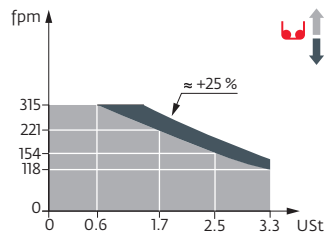

50 LVF 15 Optima

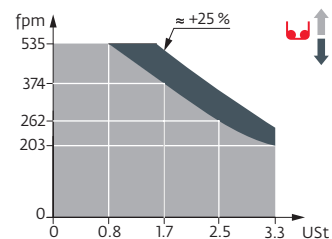



These mast combinations meet the EN 14439 and ASME B30.3-2012 specifications for "out of service" wind conditions, provided the illustrated wind speed matches required design wind for the location of the tower crane. The "out of service" design wind speed was determined in accordance with ASCE 7-10, Figure 26.5-A. The wind velocity, used for this configuration was 98 mph (158 kph), which represents a nominal design 3-second wind gust at 33 ft (10 m) above ground for Exposure B category A. Factor of 0.85 was applied to the 50-year ultimate design wind speed of 115 mph (185 kph), per ASCE 37-02, with the assumption that this crane is considered a temporary structure used during a construction period of 2 years or less.

- | | | | | | |
|--|--|--|---|--|---|
| | Jib elevation | | Total ballast weight | | Travelling |
| | Standard equipment | | Jib weight | | Required power |
| | Options | | Lorry 44 ft | | Power Control Function: winch speeds adapted to the available power |
| | Potain Plus function: Plus load curves | | Container High Cube 40 ft, and/or Flat Rack 20 ft | | Consult us |
| | Hook heights with Plus load curves | | Trolleying | | |
| | Reactions in service | | Slewing | | |
| | Reactions out of service | | Hoisting | | |

This commercial document is not legally binding. For any technical information, please refer to the corresponding instructions.

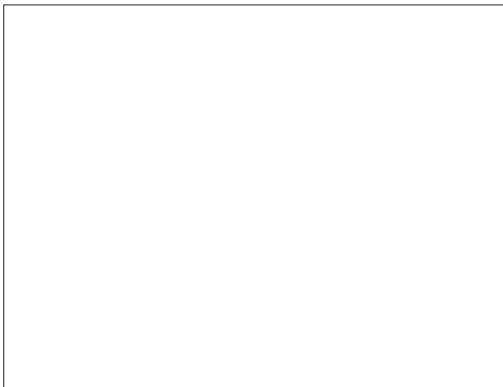

Americas
Manitowoc, Wisconsin, USA
 Tel: +1 920 684 6621
 Fax: +1 920 683 6277

Shady Grove, Pennsylvania, USA
 Tel: +1 717 597 8121
 Fax: +1 717 597 4062

Europe, Middle East, Africa
Dardilly, France
 Tel: +33 (0)4 72 18 20 20
 Fax: +33 (0)4 72 18 20 00

China
Shanghai, China
 Tel: +86 21 6457 0066
 Fax: +86 21 6457 4955

Greater Asia-Pacific
Singapore
 Tel: +65 6264 1188
 Fax: +65 6862 4040

www.manitowoccranes.com

©2016 All Rights Reserved – Manitowoc Cranes, LLC and its affiliates.

Ref 02D ASCEUSt MDT139 2015 39-2