



Technical Data

Specifications & Capacities

RTC 80150

Series II
150 US ton
130 metric ton

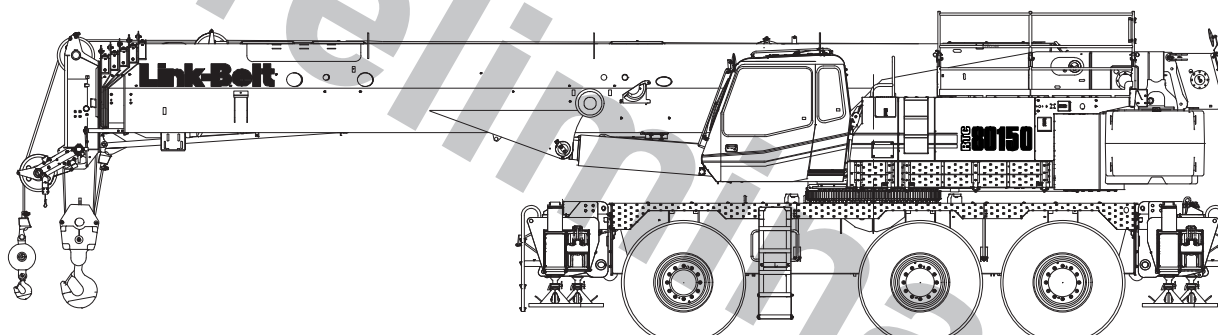

CAUTION: This material is supplied for reference use only. Operator must refer to in-cab Crane Rating Manual and Operator's Manual to determine allowable crane lifting capacities and assembly and operating procedures.





Table Of Contents

Boom, Attachments, and Upper Structure	1
Boom	1
Boom	1
Boom Wear Pads	1
Boom Head	1
Boom Elevation	1
Auxiliary Lifting Sheave – Optional	1
Hook Blocks and Balls – Optional	1
Fly – Optional	1
Fly Extensions – Optional	1
Operator’s Cab and Controls	2
Swing	3
Electrical	3
Load Hoist System	4
Load Hoist Performance	4
2M Main (Front) and Optional Auxiliary (Rear) Winches	4
Engine	4
Drive System	5
Fuel Tank	5
Hydraulic System	5
Pump Drive	5
Counterweight	5
Carrier	7
General	7
Outriggers	7
Steering and Wheel Drive Motors	7
Suspension	7
Tires and Wheels	7
Brakes	7
Electrical	7
Hydraulic System	7
Axle Loads – Imperial	8
Axle Loads – Metric	9
General Dimensions	10
Boom Extend Modes	11
Main Boom Lift Capacity Charts – Imperial	12
35,000 lb Counterweight – Fully Extended Outriggers – 360° Rotation	12
59,000 lb Counterweight – Fully Extended Outriggers – 360° Rotation	14
Manual Offset Fly Attachment Lift Capacity Charts – Optional	16
35,000 lb Counterweight – Fully Extended Outriggers – 360° Rotation	16
59,000 lb Counterweight – Fully Extended Outriggers – 360° Rotation	17
35,000 lb Counterweight – Fully Extended Outriggers – 360° Rotation	18
195.3 ft Main Boom Length	18
59,000 lb Counterweight – Fully Extended Outriggers – 360° Rotation	19
195.3 ft Main Boom Length	19
59,000 lb Counterweight – Fully Extended Outriggers – 360° Rotation	20
195.3 ft Main Boom Length	20



Hydraulic Offset Fly Attachment Lift Capacity Charts – Optional	21
35,000 lb Counterweight – Fully Extended Outriggers – 360° Rotation	21
Main Boom + 10 ft Hydraulic Offset Fly (2°–45° Offsets)	21
59,000 lb Counterweight – Fully Extended Outriggers – 360° Rotation	22
Main Boom + 10 ft Hydraulic Offset Fly (2°–45° Offsets)	22
35,000 lb Counterweight – Fully Extended Outriggers – 360° Rotation	23
195.3 ft Main Boom Length	23
59,000 lb Counterweight – Fully Extended Outriggers – 360° Rotation	24
195.3 ft Main Boom Length	24
59,000 lb Counterweight – Fully Extended Outriggers – 360° Rotation	25
195.3 ft Main Boom Length	25

Boom, Attachments, and Upper Structure

■ Boom

Design – Six section, formed construction of extra high tensile steel consisting of one base section and five telescoping sections. The two plate design of each section has multiple longitudinal bends for superior strength. Each telescoping section extends independently by means of one double-acting, single stage hydraulic cylinder with integral holding valves.

Boom

- 42.3–195.3 ft (12.9–59.5m) six section boom
- Five boom extend modes (EM1 through EM5), controlled from the operator's cab, provide superior capacities by varying the extension of the telescoping sections:
 - EM1 extends to 195.3 ft (59.5m)
 - EM2 extends to 180.3 ft (55.0m)
 - EM3 extends to 155.0 ft (47.2m)
 - EM4 extends to 129.6 ft (39.5m)
 - EM5 extends to 103.7 ft (31.6m)
- Mechanical boom angle indicator
- Maximum tip height for each extend mode is:
 - EM1 is 204 ft (62.2m)
 - EM2 is 189 ft (57.6m)
 - EM3 is 164 ft (50.0m)
 - EM4 is 139 ft (42.4m)
 - EM5 is 113 ft (34.4m)

Boom Wear Pads

- Wear pads with Teflon inserts that self-lubricate the boom sections
- Bottom wear pads are universal for T2–T5 telescoping boom sections
- Bottom wear pads are universal for the boom base section and T1 boom section
- Top wear pads are universal for all boom sections

Boom Head

- Six 16.38 in (41.6cm) root diameter nylon sheaves to handle up to twelve parts of line
- Easily removable wire rope guards
- Rope dead end lugs on each side of the boom head
- Boom head is designed for quick-reeve of the hook block

Boom Elevation

- One double acting hydraulic cylinder with integral holding valve
- Boom elevation: –2.5° to 80°

Auxiliary Lifting Sheave – Optional

- Single 16.38 in (41.6cm) root diameter nylon sheave
- Easily removable wire rope guards
- Does not affect erection of the fly or use of the main head sheaves

Hook Blocks and Balls – Optional

- 140 ton (127.0mt) 7 sheave, quick-reeve hook block with safety latch
- 100 ton (90.7mt) 6 sheave, quick-reeve hook block with safety latch
- 80 ton (72.5mt) 5 sheave, quick-reeve hook block with safety latch
- 50 ton (45.3mt) 4 sheave, quick-reeve hook block with safety latch
- 35 ton (31.7mt) 1 sheave, quick-reeve hook block with safety latch
- 12 ton (10.8mt) hook ball (swivel) with safety latch

Fly – Optional

- 31 ft–55 ft (9.4–16.8m) two piece bi-fold lattice fly, stowable, offsettable to 2°, 15°, 30°, and 45°. Maximum tip height is 258 ft (78.6m).
- 10 ft–31 ft – 55 ft (3.0, 9.4–16.8m) three piece bi-fold lattice fly, stowable, offsettable to 2°, 15°, 30°, and 45°. Maximum tip height is 258 ft (78.6m).
- 10 ft–31 ft – 55 ft (3.0, 9.4–16.8m) three piece bi-fold lattice fly, stowable, hydraulically offsettable from 2° through 45°. Maximum tip height is 258 ft (78.6m).

Fly Extensions – Optional

- One 18 ft (5.5m) lattice extension, equipped with two 16.38 in (41.6cm) root diameter nylon sheaves, to be mounted between the boom head and fly options. Maximum tip height is 276 ft (84.1m). Minimum of 35,000 lb (15 876kg) of counterweight required.
- Two 18 ft (5.5m) lattice extensions, one equipped with two 16.38 in (41.6cm) root diameter nylon sheaves, to be mounted between the boom head and fly options. Maximum tip height is 293 ft (89.3m). Minimum of 35,000 lb (15 876kg) of counterweight required.
- Three 18 ft (5.5m) lattice extensions, one equipped with two 16.38 in (41.6cm) root diameter nylon sheaves, to be mounted between the boom head and fly options. Maximum tip height is 311 ft (94.8m). Minimum of 35,000 lb (15 876kg) of counterweight required.

■ Operator's Cab and Controls

Environmental Cab – Fully enclosed, one person cab of galvaneal steel structure with acoustical insulation.

Equipped with:

- Tilting cab up to 20°
- Seat belt
- Tinted and tempered glass windows
- Five way adjustable, cushioned seat with headrests, removeable back and seat belt
- Extra—large fixed front window with windshield wiper and washer
- Swing up roof window with windshield wiper and washer
- Sliding left side door with large fixed window
- Sliding right side window for ventilation
- Engine dependent warm – water heater with air ducts for front windshield defroster and cab floor
- Defroster fan for the front window
- Bubble level
- Circulating fan
- Sun screen
- LED dome lights
- Cup holder
- Fire extinguisher
- Left side viewing mirror
- Two position travel swing lock

Air Conditioning – Integral with cab heating system utilizing the same ventilation outlets

Steering Column – Pedestal type with tilt and telescope functions for operator comfort. Column includes the following controls and indicators:

Left and right levers include:

- Horn button
- Turn signal switch
- Driving light switch
- Forward/Neutral/Reverse direction switch

Panel mounted switches for:

- Travel park brake
- Steer mode selector
- 2/6 wheel drive/range selector
- Hazard flasher

Panel mounted indicator/warning lights for:

- Travel park brake
- Service brake
- Turn signals
- Case filter restriction
- Charge filter restriction
- Engine overspeed
- Rear wheel offset
- Emergency steer – optional

Armrest Controls – Two dual axis electronic joystick controllers or optional single axis electronic controllers for:

- Swing
- Boom hoist
- Main front winch
- Auxiliary rear winch – optional
- Drum rotation indication
- Drum rotation indicator activation switch
- Winch high/low speed disable switch(es)
- Cab heater and A/C controls
- Throttle unlock switch
- Throttle set switch
- Remote boom floodlight controls (optional)
- Cab tilt switch
- Warning horn button
- Swing park brake

Foot Controls

- Boom Telescope
- Swing brake
- Engine throttle
- Travel brake

Right Front Console – Controls and indicators for:

- Warning horn button
- Function disable switch
- Cab floodlights switch
- Console dimmer switch
- (2)—12 volt accessory outlet (Switched & Unswitched)
- Emergency engine shutdown
- Windshield wiper/washer switch
- Ignition switch
- Programmable engine preheater
- Ignition indication light
- Boom floodlights switch – optional
- Rotating beacon/strobe light switch – optional
- Luffing fly switch – optional
- Pump disconnect switch

Cab Instrumentation – Ergonomically positioned LCD display, CAN bus instrumentation for crane operation including:

- Tachometer
- Engine water temperature
- Fuel level
- Diesel exhaust fluid (DEF) level (Tier 4f/Stage IV engine only)
- Hydraulic oil temperature
- Travel circuit temperature
- Stop engine light
- Check engine light
- Wait to start light
- High exhaust temperature light (Tier 4f/Stage IV engine only)
- Aftertreatment regeneration light (Tier 4f/Stage IV engine only)
- Regeneration Disabled light (Tier 4f/Stage IV engine only)
- Diesel Exhaust Fluid (DEF) low level light (Tier 4f/Stage IV engine only)
- Swing park brake light
- Fine metering function set & %
- Engine speed
- Engine air filter high restriction light
- Engine oil pressure light
- Battery voltage light
- Service brake pressure low light
- Fuel rate (gal/hr)
- Engine load
- Third wrap indicator activation & setup – optional
- Engine Diagnostics
- Electronic Control Diagnostics
- Aftertreatment regeneration inhibit switch (Tier 4f/Stage IV engine only)
- Aftertreatment regeneration initiate switch (Tier 4f/Stage IV engine only)
- LCD camera display
 - One for right side view along catwalk
 - One for front winch
 - One for rear winch – optional
- Service interval indicator
 - Hydraulic oil
 - Engine oil
 - Miscellaneous – user defined

Diagnostic Center – Located on the left side of the front panel below the windshield

- Engine diagnostic
- RCL CAN bus diagnostic
- Crane Controller USB diagnostic
- RCL controller USB diagnostic
- Boom CAN bus diagnostic

Link-Belt Pulse – The Link-Belt in-house designed, total crane operating system that utilizes the display as a readout and operator interface for the following systems:

- **Rated capacity limiter** – LCD graphic audio – visual warning system integrated into the dash with anti – two block and function limiter. Operating data includes:
 - Crane configuration
 - Boom length
 - Boom head height
 - Allowed load and % of allowed load
 - RCL light bar
 - Boom angle
 - Radius of load
 - Actual load
 - Wind speed
 - Highlighted unit of measurement on working screen
 - Telescope operation displayed in real time
 - Third wrap indicator
 - Diagnostics
 - Operator settable alarms (include):
 - Maximum and minimum boom angles
 - Maximum tip height
 - Maximum boom length
 - Swing left/right positions
 - Operator defined area (imaginary plane)
 - Outrigger position sensing
 - Drum rotation direction indication
 - Diagnostics

Integrated Third Wrap Indicator – Optional – Link–Belt Pulse color display visually and audibly warns the operator when the wire rope is down to the last three wraps.

Integrated Third Wrap Function Kickout – Optional – Link–Belt Pulse color display visually and audibly warns the operator when the wire rope is on the first/bottom layer and provides a function kickout when the wire rope is down to the last three wraps.

Internal RCL Light Bar – Optional – Visually informs the operator when crane is approaching maximum load capacity with a series of green, yellow, and red lights.

External RCL Light Bar – Optional – Visually informs the ground crew when crane is approaching maximum load capacity with a series of green, yellow, and red lights.

Extend Control Module

- Controls the extend modes
- Diagnostics

Electronic Controllers

- Controls all load lifting functions
- Diagnostics

Fine Metering

- Controls the initial reaction speeds of the main and auxiliary winches, boom hoist, and swing functions.
- Diagnostics

■ Swing

Motor/Planetary – Bi–directional hydraulic swing motor mounted to a planetary reducer for 360° continuous smooth swing at 1.5 rpm.

Swing Park Brake – 360°, electric over hydraulic, (spring applied/hydraulic released) multi–disc brake mounted on the speed reducer. Operated by a switch from the operator's cab.

Swing Brake – 360°, foot operated, hydraulic applied disc brake mounted to the speed reducer.

Swing Lock – Two–position swing lock (boom over front or rear) operated from the operator's cab.

■ Electrical

Swing Alarm – Audio warning device signals when the upper is swinging.

Lights

- Two LED working lights on front of the cab
- One rotating amber beacon on top of the cab – optional
- One amber strobe beacon on top of the cab – optional
- Boom LED floodlight – Single– optional
- Boom LED floodlight – Dual– optional
- Boom floodlight – High intensity remote controlled– optional

Electrical Center

- RCL by–pass switch
- Hour meter
- Battery disconnect switches
- 3 batteries provide 12 volt operation and starting
- Jumper posts
- Circuit breakers
- Outrigger position sensing CAN bus diagnostic port



■ Load Hoist System Load Hoist Performance

Main (Front) and Auxiliary (Rear) Winches – 7/8 in (22mm) Rope										
Layer	Maximum Line Pull		Normal Line Speed		High Line Speed		Layer		Total	
	lb	kN	ft/min	m/min	ft/min	m/min	ft	m	ft	m
1	22,510	100.13	131	39.9	262	79.9	125	38.1	125	38.1
2	20,309	90.34	145	44.2	291	88.7	138	42.0	263	80.2
3	18,501	82.3	159	48.8	319	97.2	152	46.3	414	126.5
4	16,989	75.57	174	53.0	348	106.0	165	50.3	579	179.2
5	15,705	64.86	188	57.3	376	114.6	179	54.6	758	231.3
6	14,601	64.95	202	61.5	405	123.4	192	58.5	950	289.9

Wire Rope Application		Diameter		Type	Maximum Permissible Load	
		in	mm		lb	kg
Main (Front) Winch	Standard	7/8	22	18x19 rotation resistant – right regular lay (Type RB)	17,520	7 946.9
	Optional	7/8	22	4 strand, low torque – right regular lay (Type GC)	30,285	13 737.0
	Optional	7/8	22	34x7 rotation resistant – right regular lay (Type ZB)	20,920	9 489.2
Auxiliary (Rear) Winch	Standard	7/8	22	18x19 rotation resistant – right regular lay (Type RB)	17,520	7 946.9
	Optional	7/8	22	4 strand, low torque – right regular lay (Type GC)	30,285	13 737.0
	Optional	7/8	22	34x7 rotation resistant – right regular lay (Type ZB)	20,920	9 489.2

2M Main (Front) and Optional Auxiliary (Rear) Winches

- Axial piston, full and half displacement (2–speed) motors driven through planetary reduction unit for positive control under all load conditions.
- Grooved lagging
- Power up/down mode of operation
- Hoist drum cable follower – optional
- Drum rotation indicator
- Drum diameter: 15 in (38.1cm)
- Rope length:
 - Main (Front): 900 ft (274.3m)
 - Auxiliary (Rear): 675 ft (205.7m) or 900 ft (274.3m)
- Maximum rope storage: 951 ft (289.9m)
- Terminator style socket and wedge

■ Engine

Specification	Cummins QSL	
Numbers of Cylinders	6	6
Cycle	4	4
Emissions Compliance Level:	Tier 4f/Stage IV ⁽¹⁾	Tier 3/Stage IIIA ⁽²⁾
Bore and Stroke: inch (mm)	4.49 x 5.69 (114 x 145)	4.49 x 5.69 (114 x 145)
Piston Displacement: in ³ (L)	543 (8.90)	543 (8.90)
Max. Brake Horsepower: hp (kW)	345 (257) @ 2,000 rpm	350 (261) @ 1,900 rpm
	333 (248) @ 2,100 rpm	325 (242) @ 2,100 rpm
Peak Torque: ft lb (Nm)	1,050 (1 424) @ 1,500 rpm	1,050 (1 424) @ 1,500 rpm
Electric/starting systems: volts	12/12	12/12
Alternator: amps	160	160
Crankcase Capacity: qt (L)	24 (22.7)	24 (22.7)
<ul style="list-style-type: none"> • Water/fuel separator w/ heater and water in fuel (WIF) sensor • 120–volt block heater–Tier 4f/Stage IV • 240–volt block heater–Tier 3/Stage IIIA • Grid heater – 200 amp • ⁽¹⁾ Can only be sold and/or operated where Tier 4f and Stage IV off–highway emission standards are accepted. • ⁽²⁾ Can only be sold and/or operated where Tier 3 and Stage IIIA off–highway emission standards are accepted. 		

■ Drive System

Hydrostatic type consisting of two variable speed piston pumps supplying hydraulic power to six hydraulic cam lobe wheel drive motors computer controlled for smooth and reliable operation.

■ Fuel Tank

One 90 gal (340.6L) capacity tank

Diesel Exhaust Fluid (DEF) Tank

- One 10 gal (37.9L) capacity tank

■ Hydraulic System

All functions are hydraulically powered allowing positive precise control with independent or simultaneous operation of all functions.

Main Pumps

- One, two section gear pump for the boom hoist, telescope, and charge circuits.
- Two, closed-loop piston pumps serve as travel pumps. These two pumps supply hydraulic power to the wheel motors.
- Two, closed-loop piston pumps are mounted to the rear of the two travel pumps. The left pump drives the front winch and the right pump drives the optional rear winch.
- One, pressure compensated piston pump mounted to the rear of the left winch pump supplies hydraulic power to the outrigger, counterweight removal (optional), hydraulically offstable fly (optional), oscillation, and travel brake circuits.
- One, single section gear pump mounted to the rear of the right side winch pump supplies hydraulic power to the swing and steering circuits.
- One, single section gear pump mounted to the engine front gear train accessory drive supplies hydraulic power to the hydraulic system cooling fan motor.

Hydraulic Reservoir – 255 gal (965.3L) capacity equipped with sight level gauge. Diffuser built in for deaeration. Magnetic drain plug and large internal magnet.

Filtration

- One, 7-micron filter located inside hydraulic reservoir, accessible for easy replacement
- One, 7-micron charge filter located next to the reservoir with an in-cab indicator light
- Two, 10-micron pressure filters located next to the reservoir with change indicators
- Three, 100 mesh suction strainers located inside the hydraulic reservoir

Counterbalance Valves – Boom extend cylinder and boom hoist cylinder are equipped with counterbalance valves to provide load lowering and prevents accidental load drop when hydraulic power is suddenly reduced.

■ Pump Drive

- All pumps except the hydraulic system, cooling fan, drive pump are mounted on the pump drive gearbox and mechanically driven by the diesel engine
- Boom hoist/telescope pump can be disconnected using a switch in the cab to aid in cold weather starting

■ Counterweight

Standard – Total of 35,000 lb (15 875kg) consisting of auxiliary winch or 2,000 lb (907kg) top counterweight, two 14,700 lb (6 668kg) and one 3,600 lb (1 633kg) removable counterweights pinned to the upper with capacities for:

- 0 lb (0kg) counterweight
- 16,700 lb (7 575kg) counterweight
- 20,300 lb (9 208kg) counterweight
- 31,400 lb (14 243kg) counterweight
- 35,000 lb (15 876kg) counterweight

Optional – Total of 24,000 lb (10 886kg) in addition to standard counterweight for a total of 59,000 lb (26 762kg) counterweight with additional capacities for:

- 59,000 lb (26 762kg) counterweight*

* Overall width of the crane increases to 15 ft 9 in (4.8m) for this counterweight configuration.

Hydraulic Counterweight Removal – Optional – Activated by a hand-held controller with enough cable to access the pins on each side of the counterweights.

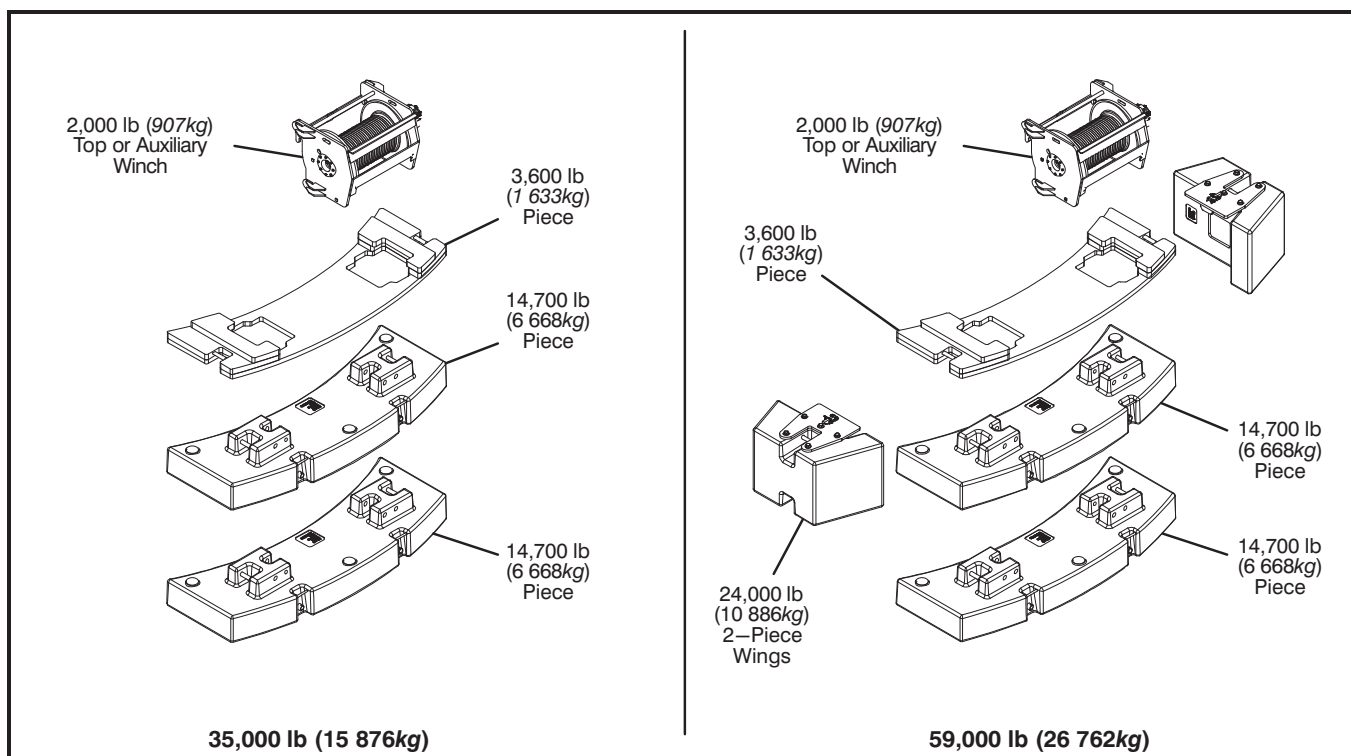

Counterweight Packages		35,000 lb (15 876kg) – Standard				
		59,000 (26 762kg) – Optional				
Counterweight Modules		3,600 lb (1 633kg) Piece	14,700 lb (6 668kg) Piece	14,700 lb (6 668kg) Piece	2,000 lb (907kg) Top*	24,000 lb (10 886kg) 2-Piece
Counterweight Usage Configurations	0 lb (0kg)					
	16,700lb (7 575kg)		X		X	
	20,300 lb (9 208kg)	X	X		X	
	31,400 lb (14 243kg)		X	X	X	
	35,000 lb (15 876kg)	X	X	X	X	
	59,000 lb (26 762kg)	X	X	X	X	X

* Auxiliary winch replaces this counterweight for a two-drum configuration

Carrier

■ General

- 9 ft 10 in (3.00m) wide
- 16 ft 1 in (4.90m) wheelbase (centerline of first axle to centerline of third axle).

Frame – Box–type, torsion resistant, welded construction made of high tensile steel. Equipped with front and rear towing and tie–down lugs, tow connections, and access ladders.

■ Outriggers

Boxes – Two removable, double box, front and rear pinned to carrier frame. Hydraulic hoses have quick–disconnect fittings for ease for box removal. Hydraulic outrigger pin removal activated by a hand–held controller – optional.

Beams and Jacks – Four single stage beams with Confined Area Lifting Capacities (CALC™) provide selectable outrigger extensions of full, intermediate, and retracted. Hydraulically controlled from the operator’s cab with integral check valves.

Pontoons – Four lightweight, quick release, 26 in (0.66m) diameter, steel pontoons with contact area of 531 in² (3 425cm²) can be stored for road travel in storage racks on the carrier.

Main Jack Reaction – 160,000 lb (72 574kg) force and 301 psi (2 075.3kPa) ground bearing pressure.

■ Steering and Wheel Drive Motors

Steering – Four independent modes consisting of two wheel front, four wheel rear, six wheel, and crab. Each mode is controlled from the steering wheel and is selected by a switch in the operator’s cab.

Drive – Three modes: 6x2 high, 6x2 low, and 6x6 for off highway travel

Front Drive Motors – Steered, driven for 6x2 and 6x6

Rear Drive Motors – Steered, non–driven for 6x2 and steered, driven for 6x6

■ Suspension

Front – Double “A” arms connected to oscillation cylinders that lockout when the upper structure rotates 3° past centerline of rotation.

Left Rear – Center and rear wheels mounted on double “A” arms connected to oscillation cylinders that lockout when the upper structure rotates 3° past centerline of rotation. Oscillation occurs across left center and left rear wheels.

Right Rear – Center and rear wheels mounted on double “A” arms connected to oscillation cylinders that lockout when the upper structure rotates 3° past centerline of rotation. Oscillation occurs across right center and right rear wheels.

Ride Height Adjustment – Suspension can be lowered for transport using a hand–held controller from the ground.

■ Tires and Wheels

Front and Rear – Six (single) 23.5R25, earthmover type tires on steel disc wheels

- Spare tires and wheels – optional

■ Brakes

Service – Full hydraulic, dual circuit, disc type brakes on all wheel ends

Parking/Emergency – Spring loaded type, acting on front wheel ends

■ Electrical

Lights

- Front lighting includes two main headlights and two parking/directional indicators
- Side lighting includes two parking/directional indicators per side
- Rear lighting includes two parking/directional indicators, two parking/brake lights, and two reverse lights
- Other equipment includes hazard/warning system

■ Hydraulic System

Drive System – Hydrostatic type consisting of two variable speed piston pumps supplying hydraulic power to six hydraulic cam lobe wheel drive motors computer controlled for smooth and reliable operation.

Filtration – One, 60–micron, full flow, line filter in the wheel motor case drain circuit. Filter includes an in–cab change indicator. Accessible for easy filter replacement.



Axle Loads - Imperial

Base machine with full tank of fuel and 35,000 lb of counterweight	Gross Vehicle Weight ⁽¹⁾	Upper Facing Front		Upper Facing Rear	
		Front Axle	Rear Axle Group	Front Axles	Rear Axle Group
	lb	lb	lb	lb	lb
	143,250	42,930	100,320	65,597	77,653
Operator in cab	250	154	96	39	211
Hydraulic outrigger pin removal	206	79	127	79	127
Remove outrigger boxes and beams	- 17,130	- 6,484	- 10,646	- 6,684	- 10,646
Pintle hook, front	13	20	- 7	20	- 7
Pintle hook, rear	13	- 10	23	- 10	23
Hydraulic counterweight removal	446	- 229	675	- 229	- 675
59,000 lb total counterweight	24,000	- 12,808	36,808	31,257	- 7,257
Remove 14,700 lb counterweight	- 14,742	7,867	- 22,609	- 19,200	4,458
Remove 14,700 lb counterweight	- 14,742	7,867	- 22,609	- 19,200	4,458
Remove 3,600 lb counterweight	- 3,600	1,921	- 5,521	- 4,689	1,089
Remove 2,000 lb counterweight - for one winch configuration only	- 2,017	1,304	- 3,321	- 2,855	838
Hoist drum follower - main	99	- 49	148	125	- 26
Auxiliary winch with 675 ft of wire rope	1,099	- 618	1,717	- 618	1,717
Remove auxiliary winch with 675 ft of wire rope - for two winch configuration only	- 2,922	1,846	- 4,678	- 4,092	1,170
Hoist drum follower - auxiliary	101	- 75	176	153	- 52
Remove 900 ft of wire rope - main winch	- 1,535	575	- 2,110	- 1,755	220
Remove 675 ft of wire rope - auxiliary winch	- 1,157	662	- 1,819	- 1,557	395
Substitute 675 ft of wire rope with 900 ft of wire rope - auxiliary winch	378	- 216	594	507	- 129
360° mechanical swing lock	140	57	83	50	90
Air conditioning	86	42	44	24	62
Auxiliary lifting sheave	120	362	- 242	- 269	389
Boom floodlight	7	18	- 11	- 13	20
Fly mounting brackets to boom base for fly options	290	508	- 218	- 285	575
31- 55 ft offsettable, two piece bi- fold fly - stowed	2,739	4,859	- 2,210	- 2,753	5,492
10- 31- 55 ft offsettable, three piece bi- fold fly - stowed	3,363	6,383	- 3,020	- 3,798	7,161
10- 31- 55 ft hydraulically offsettable, three piece bi- fold fly - stowed	3,804	7,592	- 3,788	- 4,667	8,471
Additional components for hydraulically offsettable fly	469	1,026	- 557	- 665	1,134
12 ton swivel hook ball (stowed at front/rear bumper)	722	1,153	- 431	- 598	1,320
12 ton swivel hook ball (stowed at boom head)	722	2,092	- 1,370	- 1,537	2,259
35 ton 1- sheave hook block (stowed at front/rear bumper)	1,100	1,756	- 656	- 911	2,011
35 ton 1- sheave hook block (stowed at boom head)	1,100	3,188	- 2,088	- 2,342	3,442
80 ton 5- sheave hook block (stowed at front/rear bumper)	1,411	2,253	- 842	- 1,168	2,579
80 ton 5- sheave hook block (stowed at boom head)	1,411	4,089	- 2,678	- 3,004	4,415
100 ton 6- sheave hook block (stowed at front/rear bumper)	1,750	2,794	- 1,044	- 1,449	3,199
100 ton 6- sheave hook block (stowed at boom head)	1,750	5,071	- 3,321	- 3,726	5,476
140 ton 7- sheave hook block (stowed at front/rear bumper)	2,394	3,822	- 1,428	- 1,982	4,376
140 ton 7- sheave hook block (stowed at boom head)	2,394	6,938	- 4,544	- 5,097	7,491
Tire	Maximum Load				
23.5R25	57,330 lb				

(1) Adjust gross vehicle weight and axle loading according to component weight.
 Note: All weights are ±3%.



Axle Loads – Metric

Base machine with full tank of fuel and 15 876.1kg of counterweight	Gross Vehicle Weight ⁽¹⁾	Upper Facing Front		Upper Facing Rear	
		Front Axle	Rear Axle Group	Front Axles	Rear Axle Group
	kg	kg	kg	kg	kg
	64 977	19 473	45 504	29 754	35 223
Operator in cab	113	70	44	18	96
Hydraulic outrigger pin removal	93	36	58	36	58
Remove outrigger boxes and beams	-7 770	-2 941	-4 829	-3 032	-4 829
Pintle hook, front	6	9	-3	9	-3
Pintle hook, rear	6	-4	10	-4	10
Hydraulic counterweight removal	202	-104	306	-104	306
26 762kg total counterweight	10 886	-5 810	16 696	14 178	-3 292
Remove 6 668kg counterweight	-6 687	3 568	-10 255	-8 709	2 022
Remove 6 668kg counterweight	-6 687	3 568	-10 255	-8 709	2 022
Remove 1 633kg counterweight	-1 633	871	-2 504	-2 127	494
Remove 907.1kg counterweight – for one winch configuration only	-915	591	-1 506	-1 295	380
Hoist drum follower – main	45	-22	67	57	-12
Auxiliary winch with 205.7m of wire rope	499	-280	779	-280	779
Remove auxiliary winch with 205.7m of wire rope – for two winch configuration only	-1 325	837	-2 122	-1856	531
Hoist drum follower – auxiliary	46	-34	80	69	-23
Remove 274.3kg of wire rope – main winch	-696	261	-957	-645	100
Remove 205.7m of wire rope – auxiliary winch	-525	300	-825	-704	179
Substitute 205.7m of wire rope with 274.3kg of wire rope – auxiliary winch	172	-98	269	230	-59
360° mechanical swing lock	64	26	37	23	41
Air conditioning	39	19	20	11	28
Auxiliary lifting sheave	54	164	-110	-122	176
Boom floodlight	3	8	-5	-6	9
Fly mounting brackets to boom base for fly options	132	230	-99	-129	261
9.4–16.7m offsettable, two piece bi-fold fly – stowed	1 242	2 204	-1 002	-1 249	2 491
3.0–9.4–16.7m offsettable, three piece bi-fold fly – stowed	1 525	2 895	-1 370	-1 723	3 248
3.0–9.4–16.7m hydraulically offsettable, three piece bi-fold fly – stowed	1 725	3 444	-1 718	-2 117	3 842
Additional components for hydraulically offsettable fly	213	465	-253	-302	514
10.8mt swivel hook ball (stowed at front/rear bumper)	327	523	-196	-271	599
10.8mt swivel hook ball (stowed at boom head)	327	949	-621	-697	1 025
31.7mt 1–sheave hook block (stowed at front/rear bumper)	499	797	-298	-413	912
31.7mt 1–sheave hook block (stowed at boom head)	499	1 446	-947	-1 062	1 561
72.5mt 5–sheave hook block (stowed at front/rear bumper)	640	1 022	-382	-530	1 170
72.5mt 5–sheave hook block (stowed at boom head)	640	1 855	-1 215	-1 363	2 003
90.7mt 6–sheave hook block (stowed at front/rear bumper)	794	1 267	-474	-657	1 451
90.7mt 6–sheave hook block (stowed at boom head)	794	2 300	-1 506	-1 690	2 484
127.0mt 7–sheave hook block (stowed at front/rear bumper)	1 086	1 734	-648	-899	1 985
127.0mt 7–sheave hook block (stowed at boom head)	1 086	3 147	-2 061	-2 312	3 398

Tire	Maximum Load
23.5R25	26 004kg

⁽¹⁾ Adjust gross vehicle weight and axle loading according to component weight.
Note: All weights are ±3%.

General Dimensions

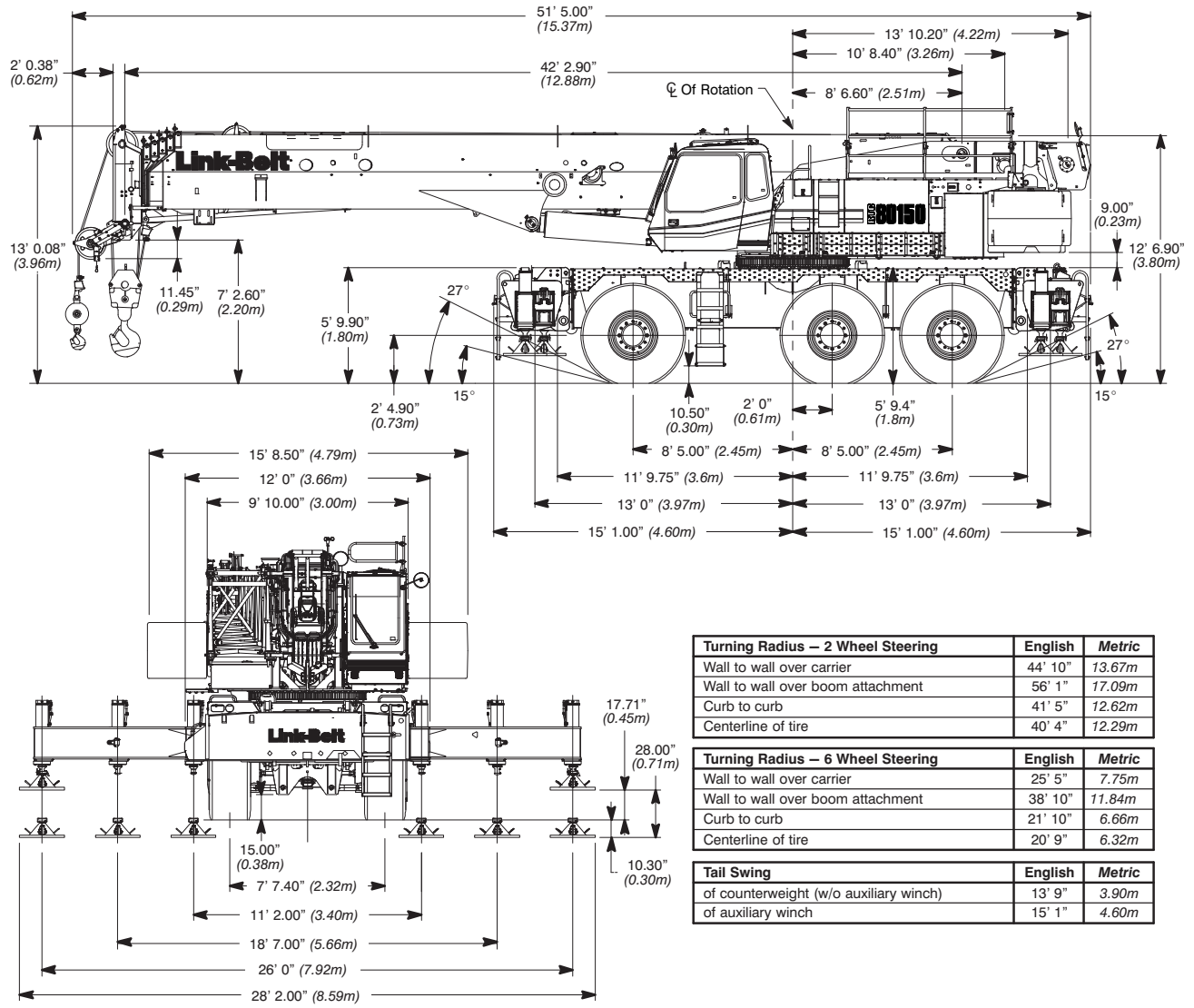

Turning Radius – 2 Wheel Steering		
	English	Metric
Wall to wall over carrier	44' 10"	13.67m
Wall to wall over boom attachment	56' 1"	17.09m
Curb to curb	41' 5"	12.62m
Centerline of tire	40' 4"	12.29m

Turning Radius – 6 Wheel Steering		
	English	Metric
Wall to wall over carrier	25' 5"	7.75m
Wall to wall over boom attachment	38' 10"	11.84m
Curb to curb	21' 10"	6.66m
Centerline of tire	20' 9"	6.32m

Tail Swing		
	English	Metric
of counterweight (w/o auxiliary winch)	13' 9"	3.90m
of auxiliary winch	15' 1"	4.60m

Boom Extend Modes

Boom Length		Telescope Length				
ft	m	T5	T4	T3	T2	T1
42.3	12.9					
55	16.8	44%				
70	21.3	96%				
85	25.9	100%	46%			
100	30.5	100%	97%			
115	35.1	100%	100%	46%		
130	39.6	100%	100%	95%		
145	44.2	100%	100%	100%	43%	
160	48.8	100%	100%	100%	90%	
175	53.3	100%	100%	100%	100%	37%
185	56.4	100%	100%	100%	100%	68%
195.3	59.5	100%	100%	100%	100%	100%

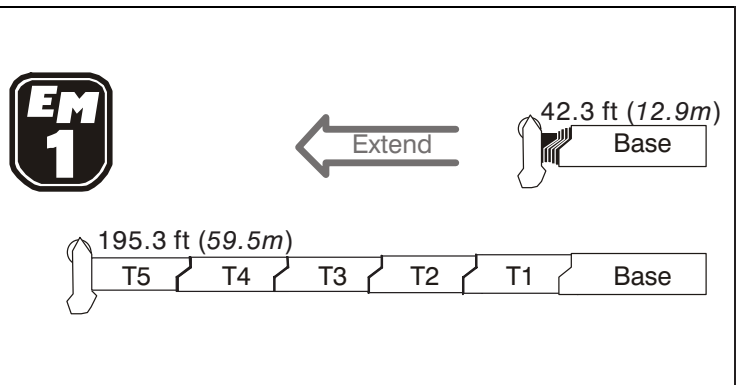

Boom Length		Telescope Length				
ft	m	T5	T4	T3	T2	T1
42.3	12.9					
55	16.8	44%				
70	21.3	90%	6%			
85	25.9	90%	57%			
100	30.5	90%	90%	17%		
115	35.1	90%	90%	66%		
130	39.6	90%	90%	90%	24%	
145	44.2	90%	90%	90%	71%	
160	48.8	90%	90%	90%	90%	28%
170	51.8	90%	90%	90%	90%	59%
180.3	55.0	90%	90%	90%	90%	91%

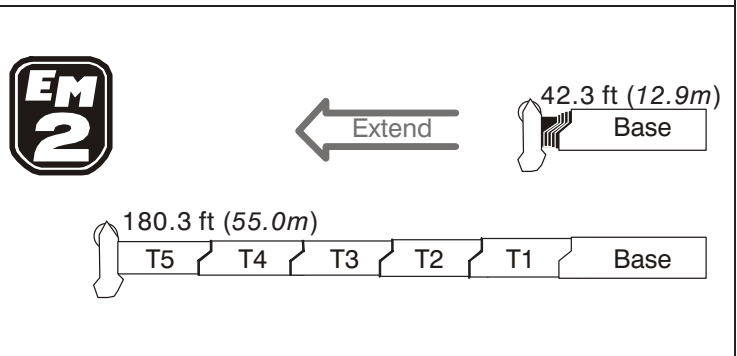

Boom Length		Telescope Length				
ft	m	T5	T4	T3	T2	T1
42.3	12.9					
55	16.8	44%				
70	21.3	46%	47%	1%		
85	25.9	46%	47%	50%		
100	30.5	46%	47%	90%	9%	
115	35.1	46%	47%	90%	457%	
130	39.6	46%	47%	90%	90%	13%
145	44.2	46%	47%	90%	90%	60%
155	47.2	46%	47%	90%	90%	91%

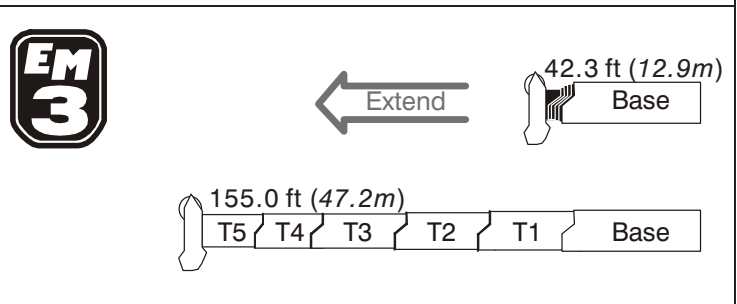

Boom Length		Telescope Length				
ft	m	T5	T4	T3	T2	T1
42.3	12.9					
55	16.8	44%				
70	21.3	46%	47%	1%		
85	25.9	46%	47%	49%	2%	
100	30.5	46%	47%	49%	49%	
115	35.1	46%	47%	49%	50%	46%
129.6	39.5	46%	47%	49%	50%	91%

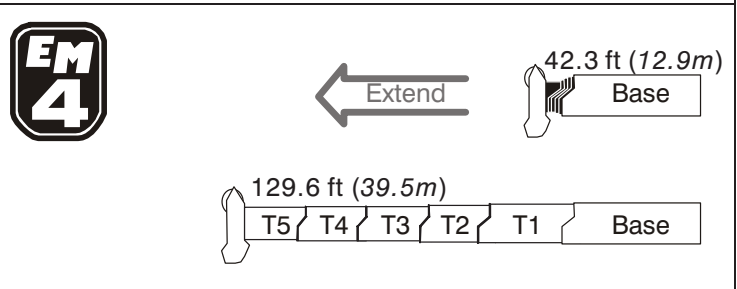

Boom Length		Telescope Length				
ft	m	T5	T4	T3	T2	T1
42.3	12.9					
56.4	17.2	0%	47%			
71.3	21.7	0%	47%	49%		
87.1	26.5	0%	47%	49%	50%	
103.7	31.6	0%	47%	49%	50%	51%

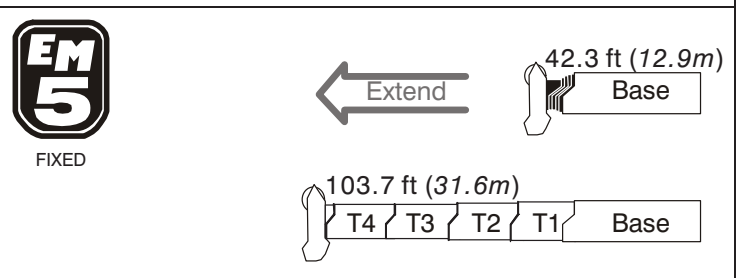



Main Boom Lift Capacity Charts – Imperial

35,000 lb Counterweight – Fully Extended Outriggers – 360° Rotation (All Capacities Are Listed In Pounds)									
Radius (ft)	Boom Length (ft)							Radius (ft)	
	42.3	55–56.35	70–71.2	85–87	100–103.7	115	129.5–130		145
8	280,000								8
9	264,700								9
10	250,200	157,100	151,700						10
12	225,300	157,100	144,800						12
15	189,300	157,100	134,400	110,100					15
20	139,900	143,200	116,200	104,700	80,700	61,300			20
25	109,300	112,700	102,200	92,200	76,400	61,300	49,400		25
30	88,500	92,000	91,100	82,200	67,400	61,300	47,200	44,300	30
35		77,100	77,300	74,100	65,000	61,300	45,200	43,700	35
40		60,300	62,600	63,000	62,100	57,300	40,600	39,600	40
45		48,700	51,100	51,500	50,800	49,500	36,600	36,300	45
50			42,600	43,000	42,400	41,100	33,200	33,300	50
55			36,900	36,500	35,900	34,700	30,300	30,700	55
60			31,900	31,500	31,000	29,800	27,700	28,300	60
65				28,900	27,500	27,000	25,200	25,600	65
70				25,500	24,800	23,600	23,100	22,200	70
75				22,600	22,900	21,500	21,000	20,100	75
80					20,500	20,200	19,700	18,800	80
85					18,700	18,600	18,000	17,700	85
90					16,900	16,900	16,300	16,400	90
95					10,300	15,300	14,800	14,700	95
100						13,800	13,800	13,300	100
105						12,600	12,500	12,100	105
110							11,400	10,900	110
115							10,300	9,900	115
120							9,400	8,900	120
125								8,100	125
130								7,300	130
135								6,600	135

Note: Capacities depict multiple boom modes.

This information is not for crane operation. Operator must refer to the in-cab information for crane operation. Rated lifting capacities shown on fully extended outriggers do not exceed 85% of the tipping loads and on tires do not exceed 75% of the tipping loads.



35,000 lb Counterweight – Fully Extended Outriggers – 360° Rotation (All Capacities Are Listed In Pounds)

Radius (ft)	Boom Length (ft)							Radius (ft)
	155	160	170	175	180.2	185	195.3	
30	35,400	30,200						30
35	35,400	30,200	28,000	24,400	24,900	18,800		35
40	35,400	30,200	28,000	24,400	24,900	18,800	16,900	40
45	32,700	30,200	28,000	24,400	24,900	18,800	16,900	45
50	29,700	28,600	28,000	24,400	24,900	18,800	16,900	50
55	27,100	26,500	27,500	24,400	24,900	18,800	16,900	55
60	24,800	24,600	25,600	23,400	24,000	18,800	16,900	60
65	22,800	22,900	23,900	21,800	22,100	18,800	16,900	65
70	20,900	21,300	22,400	20,200	20,400	18,800	16,900	70
75	18,900	19,900	20,700	18,900	18,900	18,800	16,900	75
80	16,800	18,600	18,300	17,700	17,500	17,700	16,900	80
85	14,700	17,000	16,500	16,700	16,000	16,500	15,700	85
90	12,900	15,200	14,600	15,200	14,200	14,700	14,300	90
95	11,400	13,900	13,100	13,600	12,600	13,100	12,700	95
100	10,000	12,900	11,600	12,200	11,200	11,700	11,300	100
105	8,700	11,600	10,400	10,900	9,900	10,500	10,000	105
110	7,600	10,500	9,300	9,800	8,800	9,300	8,900	110
115	6,600	9,500	8,300	8,800	7,800	8,300	7,900	115
120	5,700	8,600	7,400	7,900	6,900	7,400	7,000	120
125	4,900	7,700	6,500	7,000	6,100	6,600	6,200	125
130	4,100	6,900	5,700	6,300	5,300	5,800	5,400	130
135	3,400	6,200	5,000	5,600	4,600	5,100	4,700	135
140	2,800	5,600	4,400	4,900	4,000	4,500	4,100	140
145	2,200	5,000	3,800	4,300	3,400	3,900	3,500	145
150		4,400	3,200	3,700	2,800	3,300	2,900	150
155			2,700	3,200	2,300	2,800	2,400	155
160			2,300	2,800	1,800	2,300	1,900	160
165				2,300	1,400	1,900	1,500	165
170						1,500		170

Note: Capacities depict multiple boom modes.

This information is not for crane operation. Operator must refer to the in-cab information for crane operation. Rated lifting capacities shown on fully extended outriggers do not exceed 85% of the tipping loads and on tires do not exceed 75% of the tipping loads.



59,000 lb Counterweight – Fully Extended Outriggers – 360° Rotation (All Capacities Are Listed In Pounds)

Radius (ft)	Boom Length (ft)								Radius (ft)
	42.3	55–56.35	70–71.2	85–87	100–103.7	115	129.5–130	145	
7	300,000*								8
8	280,000								8
9	267,800								9
10	253,300	157,100	151,700						10
12	228,000	157,100	144,800						12
15	197,800	157,100	134,400	110,100					15
20	152,200	150,600	116,200	104,700	80,700	61,300			20
25	119,300	122,600	102,200	92,200	76,400	61,300	49,400		25
30	96,900	100,400	91,100	82,200	67,400	61,300	47,200	44,300	30
35		84,200	82,200	74,100	65,000	61,300	45,200	43,700	35
40		72,600	73,000	67,200	62,100	57,300	40,600	39,600	40
45		63,000	64,600	61,600	56,800	52,000	36,600	36,300	45
50			56,300	54,800	52,300	47,500	33,200	33,300	50
55			48,200	48,700	48,100	43,600	30,300	30,700	55
60			41,800	42,300	41,700	40,300	27,700	28,300	60
65				37,100	36,600	35,400	25,400	26,300	65
70				32,900	32,400	31,400	23,500	24,400	70
75				29,300	28,900	27,800	21,900	22,700	75
80					25,800	24,800	20,400	21,200	80
85					23,200	22,200	19,100	19,800	85
90					21,300	20,000	18,000	18,500	90
95					16,500	18,300	16,900	17,200	95
100						17,300	15,900	16,100	100
105						15,800	15,000	14,700	105
110							14,200	13,300	110
115							13,500	12,500	115
120							12,900	11,900	120
125								11,300	125
130								10,700	130
135								10,200	135

Note: Capacities depict multiple boom modes.
* Over front only

This information is not for crane operation. Operator must refer to the in-cab information for crane operation. Rated lifting capacities shown on fully extended outriggers do not exceed 85% of the tipping loads and on tires do not exceed 75% of the tipping loads.



59,000 lb Counterweight – Fully Extended Outriggers – 360° Rotation (All Capacities Are Listed In Pounds)

Radius (ft)	Boom Length (ft)						Radius (ft)	
	155	160	170	175	180.2	185		195.3
30	35,400	30,200						30
35	35,400	30,200	28,000	24,400	24,900	18,800		35
40	35,400	30,200	28,000	24,400	24,900	18,800	16,900	40
45	32,700	30,200	28,000	24,400	24,900	18,800	16,900	45
50	29,700	28,600	28,000	24,400	24,900	18,800	16,900	50
55	27,100	26,500	27,500	24,400	24,900	18,800	16,900	55
60	24,800	24,600	25,600	23,400	24,000	18,800	16,900	60
65	22,800	22,900	23,900	21,800	22,100	18,800	16,900	65
70	20,900	21,300	22,400	20,200	20,400	18,800	16,900	70
75	19,300	19,900	20,800	18,900	18,900	18,800	16,900	75
80	17,800	18,600	19,600	17,700	17,500	17,700	16,900	80
85	16,400	17,500	18,400	16,700	16,300	16,500	15,700	85
90	15,200	16,400	17,300	15,700	15,100	15,400	14,600	90
95	14,100	15,500	16,200	14,700	14,000	14,300	13,500	95
100	13,000	14,600	15,300	13,900	13,100	13,300	12,600	100
105	12,100	13,800	14,400	13,100	12,100	12,400	11,700	105
110	11,200	13,000	13,600	12,400	11,300	11,600	10,900	110
115	10,300	12,300	12,800	11,700	10,500	10,800	10,100	115
120	9,600	11,600	12,100	11,000	9,800	10,100	9,400	120
125	8,800	11,000	11,100	10,400	9,100	9,400	8,700	125
130	8,200	10,400	10,100	9,900	8,400	8,800	8,100	130
135	7,500	9,700	9,200	9,300	7,800	8,200	7,500	135
140	6,800	8,900	8,400	8,800	7,300	7,600	6,900	140
145	6,000	8,100	7,700	8,200	6,700	7,100	6,400	145
150		7,400	7,000	7,500	6,200	6,600	5,900	150
155			6,300	6,800	5,800	6,100	5,500	155
160			5,700	6,200	5,300	5,700	5,000	160
165				5,700	4,700	5,200	4,600	165
170					4,200	4,700	4,200	170
175						4,200	3,800	175
180							3,400	180
185							3,000	185

Note: Capacities depict multiple boom modes.

This information is not for crane operation. Operator must refer to the in-cab information for crane operation. Rated lifting capacities shown on fully extended outriggers do not exceed 85% of the tipping loads and on tires do not exceed 75% of the tipping loads.



Manual Offset Fly Attachment Lift Capacity Charts – Optional

35,000 lb Counterweight – Fully Extended Outriggers – 360° Rotation (All Capacities Are Listed In Pounds)																
Radius (ft)	Main Boom + 10 ft Manual Offset Fly (2°, 15°, 30°, 45° Offsets)														Radius (ft)	
	Boom Length (ft)															
	42.3	55	70	85	100	115	130	145	155	160	170	175	180.2	185		195.3
10	51,800	51,800														10
12	47,300	51,800	51,800													12
15	46,300	46,700	51,800	51,800												15
20	45,100	45,600	45,800	45,400	51,100											20
25	44,500	44,800	45,000	44,700	43,300	45,800	40,200									25
30	44,500	44,300	44,400	44,100	42,900	41,900	40,200	36,000	28,600	24,100		15,300				30
35	44,500	44,200	44,000	43,700	41,100	40,600	38,000	36,000	28,600	24,100	22,300	15,300	19,600	14,200	12,400	35
40	44,500	44,200	43,900	43,400	37,400	36,900	34,600	35,600	28,600	24,100	22,300	15,300	19,600	14,200	12,400	40
45		44,200	43,900	43,300	34,500	33,900	31,700	32,900	28,600	24,100	22,300	15,300	19,600	14,200	12,400	45
50		42,600	43,700	43,300	31,800	31,200	29,200	30,400	28,300	24,100	22,300	15,300	19,600	14,200	12,400	50
55		36,200	37,100	37,100	29,400	28,700	26,900	28,300	25,800	24,100	22,300	15,300	19,600	14,200	12,400	55
60			32,100	32,000	27,300	26,600	24,800	26,300	23,600	22,500	22,300	15,300	19,600	14,200	12,400	60
65			28,000	27,900	25,500	24,700	23,000	24,500	21,600	20,900	21,700	15,300	19,600	14,200	12,400	65
70			25,200	24,500	23,800	23,000	21,400	22,100	19,800	19,500	20,300	15,300	19,100	14,200	12,400	70
75				22,600	21,400	20,800	19,900	19,300	18,200	18,100	19,000	15,300	16,700	14,200	12,400	75
80				20,500	19,400	18,400	17,700	17,200	16,600	17,000	17,700	15,300	16,400	14,200	12,400	80
85				18,400	18,400	17,200	16,700	16,100	14,500	15,900	16,100	15,100	15,200	14,200	12,400	85
90					16,700	16,200	15,800	15,100	12,700	14,800	14,200	14,100	13,800	14,200	12,400	90
95					15,100	15,100	14,400	14,200	11,100	13,200	12,600	13,100	12,200	12,600	12,200	95
100					13,900	13,700	13,000	12,900	9,700	11,800	11,200	11,700	10,800	11,200	10,800	100
105						12,400	11,700	11,700	8,500	11,000	10,000	10,400	9,500	10,000	9,500	105
110						11,300	11,100	10,500	7,400	10,000	8,800	9,300	8,400	8,800	8,400	110
115						10,200	10,000	9,500	6,400	9,000	7,800	8,300	7,400	7,800	7,400	115
120							9,100	8,600	5,500	8,100	6,900	7,400	6,400	6,900	6,500	120
125							8,200	7,700	4,600	7,200	6,100	6,500	5,600	6,100	5,600	125
130							7,500	7,000	3,900	6,500	5,300	5,800	4,800	5,300	4,900	130
135								6,300	3,200	5,800	4,600	5,100	4,100	4,600	4,200	135
140								5,600	2,500	5,100	4,000	4,400	3,500	4,000	3,500	140
145								5,000	2,000	4,500	3,400	3,800	2,900	3,400	2,900	145
150										4,000	2,800	3,300	2,400	2,800	2,400	150
155										3,400	2,300	2,800	1,900	2,300	1,900	155
160										3,000	1,800	2,300	1,400	1,800	1,400	160
165												1,800		1,400		165
170												1,400				170

This information is not for crane operation. Operator must refer to the in-cab information for crane operation. Rated lifting capacities shown on fully extended outriggers do not exceed 85% of the tipping loads and on tires do not exceed 75% of the tipping loads.



59,000 lb Counterweight – Fully Extended Outriggers – 360° Rotation

(All Capacities Are Listed In Pounds)

Radius (ft)	Main Boom + 10 ft Manual Offset Fly (2°, 15°, 30°, 45° Offsets)															Radius (ft)
	Boom Length (ft)															
	42.3	55	70	85	100	115	130	145	155	160	170	175	180.2	185	195.3	
10	51,800	51,800														10
12	47,300	51,800	51,800													12
15	46,300	46,700	51,800	51,800												15
20	45,100	45,600	45,800	45,400	51,100											20
25	44,500	44,800	45,000	44,700	43,300	45,800	40,200									25
30	44,500	44,300	44,400	44,100	42,900	41,900	40,200	36,000	28,600	24,100		15,300				30
35	44,500	44,200	44,000	43,700	41,100	40,600	38,000	36,000	28,600	24,100	22,300	15,300	19,600	14,200	12,400	35
40	44,500	44,200	43,900	43,400	37,400	36,900	34,600	35,600	28,600	24,100	22,300	15,300	19,600	14,200	12,400	40
45		44,200	43,900	43,300	34,500	33,900	31,700	32,900	28,600	24,100	22,300	15,300	19,600	14,200	12,400	45
50		44,200	43,900	43,300	31,800	31,200	29,200	30,400	28,300	24,100	22,300	15,300	19,600	14,200	12,400	50
55		42,800	43,900	43,300	29,400	28,700	26,900	28,300	25,800	24,100	22,300	15,300	19,600	14,200	12,400	55
60			42,900	40,900	27,300	26,600	24,800	26,300	23,600	22,500	22,300	15,300	19,600	14,200	12,400	60
65			37,700	37,600	25,500	24,700	23,000	24,500	21,600	20,900	21,700	15,300	19,600	14,200	12,400	65
70			33,500	33,400	23,800	23,000	21,400	22,700	19,800	19,500	20,300	15,300	19,100	14,200	12,400	70
75				29,800	22,300	21,400	19,900	21,100	18,200	18,100	19,000	15,300	16,700	14,200	12,400	75
80				26,800	21,000	20,000	18,600	19,600	16,800	17,000	17,700	15,300	16,400	14,200	12,400	80
85			24,200	19,800	18,800	17,400	18,300	15,500	15,900	16,700	15,100	15,200	14,200	12,400	12,400	85
90				18,700	17,600	16,400	17,200	14,300	14,900	15,700	14,100	14,100	14,200	12,400	12,400	90
95				17,700	16,700	15,400	16,100	13,200	14,000	14,800	13,200	13,000	13,200	12,400	12,400	95
100				17,000	15,800	14,400	15,100	12,200	13,200	14,000	12,400	12,100	12,300	11,500	11,500	100
105					14,900	13,600	14,100	11,200	12,400	13,100	11,700	11,200	11,400	10,600	10,600	105
110					14,100	12,800	13,100	10,300	11,600	12,300	11,000	10,300	10,600	9,800	9,800	110
115					13,200	12,000	11,800	9,500	10,900	11,600	10,300	9,600	9,800	9,100	9,100	115
120						11,400	10,700	8,800	10,300	10,900	9,700	8,800	9,100	8,400	8,400	120
125						10,800	10,000	8,100	9,700	10,200	9,100	8,200	8,400	7,700	7,700	125
130						10,300	9,500	7,400	9,200	9,600	8,600	7,500	7,800	7,100	7,100	130
135							9,000	6,800	8,600	8,800	8,100	6,900	7,200	6,500	6,500	135
140							8,500	6,200	8,200	8,000	7,600	6,400	6,700	6,000	6,000	140
145							8,100	5,700	7,700	7,200	7,200	5,900	6,200	5,500	5,500	145
150								5,100	7,000	6,500	6,700	5,400	5,700	5,000	5,000	150
155								4,500	6,400	5,900	6,300	4,900	5,200	4,500	4,500	155
160									5,800	5,300	5,800	4,500	4,800	4,100	4,100	160
165										4,700	5,200	4,100	4,400	3,700	3,700	165
170										4,200	4,600	3,700	4,000	3,300	3,300	170
175											4,200	3,300	3,600	2,900	2,900	175
180												2,900	3,200	2,600	2,600	180
185													2,900	2,300	2,300	185

This information is not for crane operation. Operator must refer to the in-cab information for crane operation. Rated lifting capacities shown on fully extended outriggers do not exceed 85% of the tipping loads and on tires do not exceed 75% of the tipping loads.



35,000 lb Counterweight – Fully Extended Outriggers – 360° Rotation
(All Capacities Are Listed In Pounds)
195.3 ft Main Boom Length

Radius (ft)	31 ft Hydraulic Offset Fly				55 ft Hydraulic Offset Fly				Radius (ft)
	2°	15°	30°	45°	2°	15°	30°	45°	
50	10,800								50
55	10,800				8,300				55
60	10,800	10,800			8,300				60
65	10,800	10,800			8,300				65
70	10,800	10,800	10,900		8,300	8,300			70
75	10,800	10,800	10,900	11,100	8,300	8,300			75
80	10,800	10,800	10,900	11,100	8,300	8,300			80
85	10,800	10,800	10,900	11,100	8,300	8,200	7,500		85
90	10,800	10,800	10,900	11,100	8,300	8,100	7,400		90
95	10,800	10,800	10,900	11,100	8,300	8,000	7,300		95
100	10,800	10,800	10,900	11,100	8,300	7,900	7,300	6,800	100
105	9,800	10,500	10,900	11,100	8,300	7,900	7,200	6,800	105
110	8,700	9,400	10,000	10,500	8,300	7,800	7,100	6,700	110
115	7,700	8,300	8,900	9,300	8,300	7,700	7,100	6,700	115
120	6,700	7,300	7,900	8,300	7,500	7,600	7,000	6,700	120
125	5,900	6,400	7,000	7,300	6,600	7,500	7,000	6,700	125
130	5,100	5,600	6,100	6,400	5,900	6,800	6,900	6,600	130
135	4,400	4,900	5,300	5,600	5,100	6,000	6,800	6,600	135
140	3,800	4,200	4,600	4,900	4,500	5,300	6,000	6,600	140
145	3,200	3,600	4,000	4,200	3,900	4,600	5,300	5,900	145
150	2,600	3,000	3,400	3,600	3,300	4,000	4,700	5,200	150
155	2,100	2,500	2,800	3,000	2,800	3,400	4,100	4,500	155
160	1,600	2,000	2,300	2,400	2,300	2,900	3,500	3,900	160
165	1,200	1,500	1,800	1,900	1,800	2,400	3,000	3,300	165
170			1,300	1,400	1,400	2,000	2,500	2,800	170
175						1,500	2,000	2,300	175
180						1,100	1,500	1,800	180

This information is not for crane operation. Operator must refer to the in-cab information for crane operation. Rated lifting capacities shown on fully extended outriggers do not exceed 85% of the tipping loads and on tires do not exceed 75% of the tipping loads.



59,000 lb Counterweight – Fully Extended Outriggers – 360° Rotation
(All Capacities Are Listed In Pounds)
195.3 ft Main Boom Length

Radius (ft)	31 ft Hydraulic Offset Fly				55 ft Hydraulic Offset Fly				Radius (ft)
	2°	15°	30°	45°	2°	15°	30°	45°	
50	10,800								50
55	10,800				8,300				55
60	10,800	10,800			8,300				60
65	10,800	10,800			8,300				65
70	10,800	10,800	10,900		8,300	8,300			70
75	10,800	10,800	10,900	11,100	8,300	8,300			75
80	10,800	10,800	10,900	11,100	8,300	8,300			80
85	10,800	10,800	10,900	11,100	8,300	8,200	7,500		85
90	10,800	10,800	10,900	11,100	8,300	8,100	7,400		90
95	10,800	10,800	10,900	11,100	8,300	8,000	7,300		95
100	10,800	10,800	10,900	11,100	8,300	7,900	7,300	6,800	100
105	10,300	10,700	10,900	11,100	8,300	7,900	7,200	6,800	105
110	9,500	9,900	10,300	10,600	8,300	7,800	7,100	6,700	110
115	8,800	9,200	9,500	9,800	8,300	7,700	7,100	6,700	115
120	8,200	8,500	8,800	9,100	7,900	7,600	7,000	6,700	120
125	7,600	7,900	8,200	8,500	7,300	7,500	7,000	6,700	125
130	7,000	7,300	7,600	7,800	6,700	7,200	6,900	6,600	130
135	6,500	6,800	7,000	7,200	6,200	6,700	6,900	6,600	135
140	6,000	6,200	6,500	6,700	5,700	6,200	6,600	6,600	140
145	5,500	5,700	6,000	6,100	5,300	5,700	6,100	6,400	145
150	5,000	5,300	5,500	5,600	4,800	5,200	5,600	5,900	150
155	4,600	4,800	5,000	5,200	4,400	4,800	5,200	5,500	155
160	4,200	4,400	4,600	4,700	4,000	4,400	4,700	5,000	160
165	3,800	4,000	4,200	4,300	3,700	4,000	4,300	4,600	165
170	3,400	3,600	3,800	3,900	3,300	3,600	3,900	4,100	170
175	3,100	3,300	3,400	3,500	3,000	3,300	3,600	3,700	175
180	2,800	2,900	3,000		2,600	2,900	3,200	3,400	180
185	2,400	2,600	2,700		2,300	2,600	2,800	3,000	185
190	2,100	2,300	2,400		2,000	2,300	2,500	2,600	190
195	1,900	2,000	2,100		1,800	2,000	2,200	2,300	195
200	1,500	1,600	1,700		1,500	1,700	1,900	2,000	200
205	1,200	1,300			1,200	1,400	1,600		205
210						1200	1300		210
185							1,100	1,300	185

This information is not for crane operation. Operator must refer to the in-cab information for crane operation. Rated lifting capacities shown on fully extended outriggers do not exceed 85% of the tipping loads and on tires do not exceed 75% of the tipping loads.



59,000 lb Counterweight – Fully Extended Outriggers – 360° Rotation (All Capacities Are Listed In Pounds)

195.3 ft Main Boom Length

Radius (ft)	73 ft Manual Offset Fly				91 ft Manual Offset Fly				109 ft Manual Offset Fly				Radius (ft)
	2°	15°	30°	45°	2°	15°	30°	45°	2°	15°	30°	45°	
65	6,700												65
70	6,700				5,200								70
75	6,700	6,700			5,200								75
80	6,700	6,700			5,200	5,200							80
85	6,700	6,700			5,200	5,200			3,100				85
90	6,700	6,700			5,200	5,200			3,100	3,100			90
95	6,700	6,700	6,800		5,200	5,200			3,100	3,100			95
100	6,700	6,700	6,700		5,200	5,200	5,000		3,100	3,100			100
105	6,700	6,700	6,700	6,400	5,200	5,200	5,000		3,100	3,100	3,100		105
110	6,700	6,700	6,600	6,400	5,200	5,200	4,900	4,700	3,100	3,100	3,000		110
115	6,600	6,700	6,600	6,300	5,200	5,200	4,900	4,700	3,100	3,100	2,800		115
120	5,900	6,600	6,600	6,300	5,000	5,200	4,900	4,600	3,100	3,000	2,700	2,500	120
125	5,400	6,000	6,600	6,300	4,400	5,100	4,800	4,500	3,100	2,900	2,600	2,400	125
130	4,900	5,400	6,000	6,300	3,900	4,500	4,800	4,400	2,900	2,800	2,500	2,300	130
135	4,400	4,900	5,500	5,900	3,400	4,000	4,600	4,300	2,500	2,600	2,400	2,200	135
140	3,900	4,400	5,000	5,400	3,000	3,600	4,100	4,200	2,100	2,500	2,300	2,100	140
145	3,400	4,000	4,500	4,900	2,600	3,100	3,700	4,100	1,700	2,300	2,200	2,000	145
150	3,000	3,500	4,000	4,400	2,200	2,700	3,200	3,600	1,300	1,900	2,100	1,900	150
155	2,600	3,100	3,600	3,900	1,800	2,300	2,800	3,200		1,500	2,000	1,800	155
160	2,300	2,700	3,200	3,500	1,400	1,900	2,400	2,800		1,100	1,700	1,800	160
165	1,900	2,400	2,800	3,100	1,100	1,600	2,100	2,400			1,300	1,700	165
170	1,600	2,000	2,400	2,700		1,300	1,700	2,000				1,300	170
175	1,300	1,700	2,100	2,300			1,400	1,600					175
180		1,400	1,700	1,900				1,300					180
185			1,400	1,600									185
190			1,100	1,200									190

This information is not for crane operation. Operator must refer to the in-cab information for crane operation. Rated lifting capacities shown on fully extended outriggers do not exceed 85% of the tipping loads and on tires do not exceed 75% of the tipping loads.



Hydraulic Offset Fly Attachment Lift Capacity Charts – Optional

35,000 lb Counterweight – Fully Extended Outriggers – 360° Rotation
(All Capacities Are Listed In Pounds)

Main Boom + 10 ft Hydraulic Offset Fly (2°–45° Offsets)

Radius (ft)	Main Boom Length (ft)														Radius (ft)	
	42.3	55	70	85	100	115	130	145	155	160	170	175	180.2	185		195.3
10	51,800	51,800														10
12	47,100	51,800	51,800													12
15	46,200	46,500	51,800	51,800												15
20	45,000	45,400	45,600	45,200	51,000											20
25	44,400	44,600	44,800	44,500	43,100	45,600	40,000									25
30	44,400	44,200	44,200	44,000	42,700	41,700	40,000	35,900	28,500	24,000		15,200				30
35	44,400	44,100	43,900	43,600	40,700	40,300	37,600	35,900	28,500	24,000	22,200	15,200	19,500	14,100	12,300	35
40	44,400	44,100	43,700	43,300	37,000	36,500	34,300	33,500	28,500	24,000	22,200	15,200	19,500	14,100	12,300	40
45		44,100	43,700	43,200	34,100	33,500	31,400	32,500	28,500	24,000	22,200	15,200	19,500	14,100	12,300	45
50		42,300	43,300	43,200	31,400	30,800	28,800	30,000	27,900	24,000	22,200	15,200	19,500	14,100	12,300	50
55		35,800	36,800	36,700	29,000	28,300	26,500	27,900	25,400	23,900	22,200	15,200	19,500	14,100	12,300	55
60			31,700	31,700	26,900	26,200	24,400	25,900	23,100	22,100	22,200	15,200	19,500	14,100	12,300	60
65			27,600	27,500	25,000	24,300	22,600	24,100	21,100	20,500	21,300	15,200	19,500	14,100	12,300	65
70			24,900	24,100	23,400	22,600	21,000	21,700	19,400	19,100	19,900	15,200	18,700	14,100	12,300	70
75				22,200	21,000	20,400	19,500	18,900	17,700	17,700	18,500	15,200	16,600	14,100	12,300	75
80				20,100	19,000	18,000	17,400	16,800	16,200	16,600	17,300	15,200	16,000	14,100	12,300	80
85				18,100	18,000	16,800	16,300	15,700	14,100	15,500	15,700	14,700	14,800	14,100	12,300	85
90					16,300	15,800	15,300	14,700	12,300	14,400	13,900	13,700	13,400	13,800	12,300	90
95					14,700	14,700	14,100	13,800	10,700	12,800	12,300	12,800	11,800	12,300	11,800	95
100					13,500	13,300	12,600	12,600	9,300	11,400	10,900	11,300	10,400	10,900	10,400	100
105						12,000	11,400	11,300	8,100	10,600	9,600	10,100	9,100	9,600	9,100	105
110						10,900	10,700	10,100	7,000	9,700	8,500	8,900	8,000	8,500	8,000	110
115						9,900	9,700	9,100	6,000	8,600	7,400	7,900	7,000	7,400	7,000	115
120							8,700	8,200	5,100	7,700	6,500	7,000	6,100	6,500	6,100	120
125							7,900	7,300	4,200	6,900	5,700	6,100	5,200	5,700	5,200	125
130							7,100	6,600	3,500	6,100	4,900	5,400	4,500	4,900	4,500	130
135								5,900	2,800	5,400	4,200	4,700	3,800	4,200	3,800	135
140								5,200	2,200	4,700	3,600	4,000	3,100	3,600	3,100	140
145								4,600	1,600	4,100	3,000	3,400	2,500	3,000	2,500	145
150										3,600	2,400	2,900	2,000	2,400	2,000	150
155										3,100	1,900	2,400	1,500	1,900	1,500	155
160										2,600	1,500	1,900		1,400		160
165												1,500				165

This information is not for crane operation. Operator must refer to the in-cab information for crane operation. Rated lifting capacities shown on fully extended outriggers do not exceed 85% of the tipping loads and on tires do not exceed 75% of the tipping loads.



59,000 lb Counterweight – Fully Extended Outriggers – 360° Rotation (All Capacities Are Listed In Pounds)

Main Boom + 10 ft Hydraulic Offset Fly (2°–45° Offsets)

Radius (ft)	Main Boom Length (ft)															Radius (ft)
	42.3	55	70	85	100	115	130	145	155	160	170	175	180.2	185	195.3	
10	51,800	51,800														10
12	47,100	51,800	51,800													12
15	46,200	46,500	51,800	51,800												15
20	45,000	45,400	45,600	45,200	51,000											20
25	44,400	44,600	44,800	44,500	43,100	45,600	40,000									25
30	44,400	44,200	44,200	44,000	42,700	41,700	40,000	35,900	28,500	24,000		15,200				30
35	44,400	44,100	43,900	43,600	40,700	40,300	37,600	35,900	28,500	24,000	22,200	15,200	19,500	14,100	12,300	35
40	44,400	44,100	43,700	43,300	37,000	36,500	34,300	33,500	28,500	24,000	22,200	15,200	19,500	14,100	12,300	40
45		44,100	43,700	43,200	34,100	33,500	31,400	32,500	28,500	24,000	22,200	15,200	19,500	14,100	12,300	45
50		44,100	43,700	43,200	31,400	30,800	28,800	30,000	27,900	24,000	22,200	15,200	19,500	14,100	12,300	50
55		42,500	43,700	43,200	29,000	28,300	26,500	27,900	25,400	23,900	22,200	15,200	19,500	14,100	12,300	55
60			42,500	40,500	26,900	26,200	24,400	25,900	23,100	22,100	22,200	15,200	19,500	14,100	12,300	60
65			37,300	37,200	25,000	24,300	22,600	24,100	21,100	20,500	21,300	15,200	19,500	14,100	12,300	65
70			33,200	33,100	23,400	22,600	21,000	22,300	19,400	19,100	19,900	15,200	18,700	14,100	12,300	70
75				29,500	21,900	21,000	19,500	20,700	17,700	17,700	18,500	15,200	16,600	14,100	12,300	75
80				26,400	20,600	19,600	18,200	19,200	16,400	16,600	17,300	15,200	16,000	14,100	12,300	80
85				23,800	19,400	18,400	17,100	17,900	15,100	15,500	16,300	14,700	14,800	14,100	12,300	85
90					18,300	17,200	16,000	16,800	13,900	14,500	15,300	13,700	13,600	13,800	12,300	90
95					17,300	16,300	15,000	15,700	12,800	13,600	14,400	12,800	12,600	12,800	12,000	95
100					16,600	15,300	14,000	14,600	11,800	12,700	13,500	12,000	11,600	11,800	11,100	100
105						14,500	13,100	13,700	10,800	11,900	12,700	11,200	10,700	11,000	10,200	105
110						13,700	12,300	12,700	9,900	11,200	11,900	10,500	9,900	10,100	9,400	110
115						12,800	11,600	11,400	9,100	10,500	11,100	9,900	9,100	9,400	8,700	115
120							10,900	10,300	8,300	9,900	10,400	9,300	8,400	8,700	8,000	120
125							10,300	9,600	7,600	9,300	9,800	8,700	7,700	8,000	7,300	125
130							9,900	9,000	7,000	8,700	9,200	8,200	7,100	7,400	6,700	130
135								8,500	6,400	8,200	8,400	7,600	6,500	6,800	6,100	135
140								8,100	5,800	7,700	7,600	7,200	6,000	6,300	5,600	140
145								7,700	5,200	7,300	6,800	6,700	5,400	5,700	5,000	145
150									4,700	6,700	6,200	6,300	4,900	5,300	4,600	150
155									4,100	6,000	5,500	5,900	4,500	4,800	4,100	155
160										5,400	4,900	5,400	4,000	4,400	3,700	160
165											4,300	4,800	3,600	4,000	3,300	165
170											3,900	4,300	3,200	3,600	2,900	170
175												3,800	2,900	3,200	2,500	175
180													2,500		2,200	180
185															1,800	185

This information is not for crane operation. Operator must refer to the in-cab information for crane operation. Rated lifting capacities shown on fully extended outriggers do not exceed 85% of the tipping loads and on tires do not exceed 75% of the tipping loads.



**35,000 lb Counterweight – Fully Extended Outriggers – 360° Rotation
(All Capacities Are Listed In Pounds)**

195.3 ft Main Boom Length

Radius (ft)	31 ft Hydraulic Offset Fly			55 ft Hydraulic Offset Fly			Radius (ft)
	2°–15°	15°–30°	30°–45°	2°–15°	15°–30°	30°–45°	
50	10,500						50
55	10,500			8,000			55
60	10,500	10,600		8,000			60
65	10,500	10,600		8,000			65
70	10,500	10,600	10,700	8,000	8,100		70
75	10,500	10,600	10,700	8,000	8,100		75
80	10,500	10,600	10,700	8,000	8,100		80
85	10,500	10,600	10,700	8,000	7,200	7,200	85
90	10,500	10,600	10,700	7,900	7,100	7,100	90
95	10,500	10,600	10,700	7,800	7,100	7,100	95
100	10,200	10,600	10,700	7,700	7,000	6,500	100
105	9,400	9,800	10,200	7,600	6,900	6,400	105
110	8,400	9,000	9,400	7,500	6,900	6,400	110
115	7,400	8,000	8,600	7,400	6,800	6,300	115
120	6,400	7,000	7,600	7,000	6,800	6,300	120
125	5,600	6,100	6,700	6,300	6,700	6,300	125
130	4,800	5,300	5,800	5,600	6,300	6,200	130
135	4,100	4,600	5,100	4,800	5,700	6,200	135
140	3,500	3,900	4,300	4,200	5,000	5,700	140
145	2,900	3,300	3,700	3,600	4,300	5,100	145
150	2,300	2,700	3,100	3,000	3,700	4,400	150
155	1,800	2,200	2,500	2,500	3,200	3,800	155
160	1,300	1,700	2,000	2,000	2,600	3,200	160
165		1,200	1,500	1,500	2,100	2,700	165
170				1,100	1,700	2,200	170
175					1,200	1,700	175
180						1,300	180

This information is not for crane operation. Operator must refer to the in-cab information for crane operation. Rated lifting capacities shown on fully extended outriggers do not exceed 85% of the tipping loads and on tires do not exceed 75% of the tipping loads.



**59,000 lb Counterweight – Fully Extended Outriggers – 360° Rotation
(All Capacities Are Listed In Pounds)**

195.3 ft Main Boom Length

Radius (ft)	31 ft Hydraulic Offset Fly			55 ft Hydraulic Offset Fly			Radius (ft)
	2°–15°	15°–30°	30°–45°	2°–15°	15°–30°	30°–45°	
50	10,500						50
55	10,500			8,000			55
60	10,500	10,600		8,000			60
65	10,500	10,600		8,000			65
70	10,500	10,600	10,700	8,000	8,100		70
75	10,500	10,600	10,700	8,000	8,100		75
80	10,500	10,600	10,700	8,000	8,100		80
85	10,500	10,600	10,700	8,000	7,200	7,200	85
90	10,500	10,600	10,700	7,900	7,100	7,100	90
95	10,500	10,600	10,700	7,800	7,100	7,100	95
100	10,200	10,600	10,700	7,700	7,000	6,500	100
105	9,400	9,800	10,200	7,600	6,900	6,400	105
110	8,600	9,000	9,400	7,500	6,900	6,400	110
115	7,900	8,300	8,600	7,400	6,800	6,300	115
120	7,300	7,600	7,900	7,000	6,800	6,300	120
125	6,700	7,000	7,300	6,400	6,700	6,300	125
130	6,100	6,400	6,700	5,800	6,300	6,200	130
135	5,500	5,800	6,100	5,300	5,800	6,200	135
140	5,000	5,300	5,600	4,800	5,300	5,700	140
145	4,500	4,800	5,100	4,400	4,800	5,200	145
150	4,100	4,300	4,600	3,900	4,300	4,700	150
155	3,700	3,900	4,100	3,500	3,900	4,300	155
160	3,200	3,500	3,700	3,100	3,500	3,800	160
165	2,900	3,100	3,200	2,700	3,100	3,400	165
170	2,500	2,700	2,800	2,400	2,700	3,000	170
175	2,100	2,300	2,500	2,000	2,300	2,600	175
180	1,800	2,000	2,100	1,700	2,000	2,300	180
185	1,500	1,600	1,700	1,400	1,600	1,900	185
190	1,200	1,300	1,400		1,300	1,500	190
195			1,100			1,200	195

This information is not for crane operation. Operator must refer to the in-cab information for crane operation. Rated lifting capacities shown on fully extended outriggers do not exceed 85% of the tipping loads and on tires do not exceed 75% of the tipping loads.



59,000 lb Counterweight – Fully Extended Outriggers – 360° Rotation (All Capacities Are Listed In Pounds)

195.3 ft Main Boom Length

Radius (ft)	73 ft Hydraulic Offset Fly			91 ft Hydraulic Offset Fly			109 ft Hydraulic Offset Fly			Radius (ft)
	2°–15°	15°–30°	30°–45°	2°–15°	15°–30°	30°–45°	2°–15°	15°–30°	30°–45°	
65	6,600									65
70	6,600			5,100						70
75	6,600	6,600		5,100						75
80	6,600	6,600		5,100	5,100					80
85	6,600	6,600		5,100	5,100		3,000			85
90	6,600	6,600		5,100	5,100		3,000	3,000		90
95	6,600	6,600	6,600	5,100	5,100		3,000	3,000		95
100	6,600	6,500	6,500	5,100	4,800	4,800	3,000	3,000		100
105	6,600	6,500	6,200	5,100	4,800	4,800	3,000	2,700	2,700	105
110	6,500	6,500	6,200	5,100	4,800	4,500	2,900	2,600	2,600	110
115	5,800	6,400	6,200	4,800	4,700	4,400	2,700	2,400	2,400	115
120	5,200	5,900	6,200	4,200	4,700	4,300	2,600	2,300	2,100	120
125	4,600	5,300	5,900	3,600	4,400	4,200	2,400	2,200	2,000	125
130	4,100	4,700	5,400	3,100	3,800	4,100	2,200	2,000	1,900	130
135	3,600	4,200	4,800	2,700	3,300	4,000	1,700	1,900	1,800	135
140	3,100	3,700	4,300	2,200	2,800	3,500	1,300	1,800	1,700	140
145	2,700	3,200	3,800	1,800	2,400	3,000		1,500	1,600	145
150	2,300	2,800	3,300	1,400	2,000	2,600		1,100	1,500	150
155	1,900	2,400	2,900		1,600	2,100			1,300	155
160	1,500	2,000	2,500		1,200	1,700				160
165	1,100	1,600	2,100			1,300				165
170		1,300	1,700							170
175			1,300							175

This information is not for crane operation. Operator must refer to the in-cab information for crane operation. Rated lifting capacities shown on fully extended outriggers do not exceed 85% of the tipping loads and on tires do not exceed 75% of the tipping loads.



This Page Intentionally Blank



This Page Intentionally Blank



Preliminary

Link-Belt Construction Equipment Company Lexington, Kentucky www.linkbelt.com

©Link-Belt is a registered trademark. Copyright 2013. We are constantly improving our products and therefore reserve the right to change designs and specifications.