



# Specifications

Hydraulic Lattice Boom Crawler Crane

## LS-138H

75-Ton (68 metric ton)

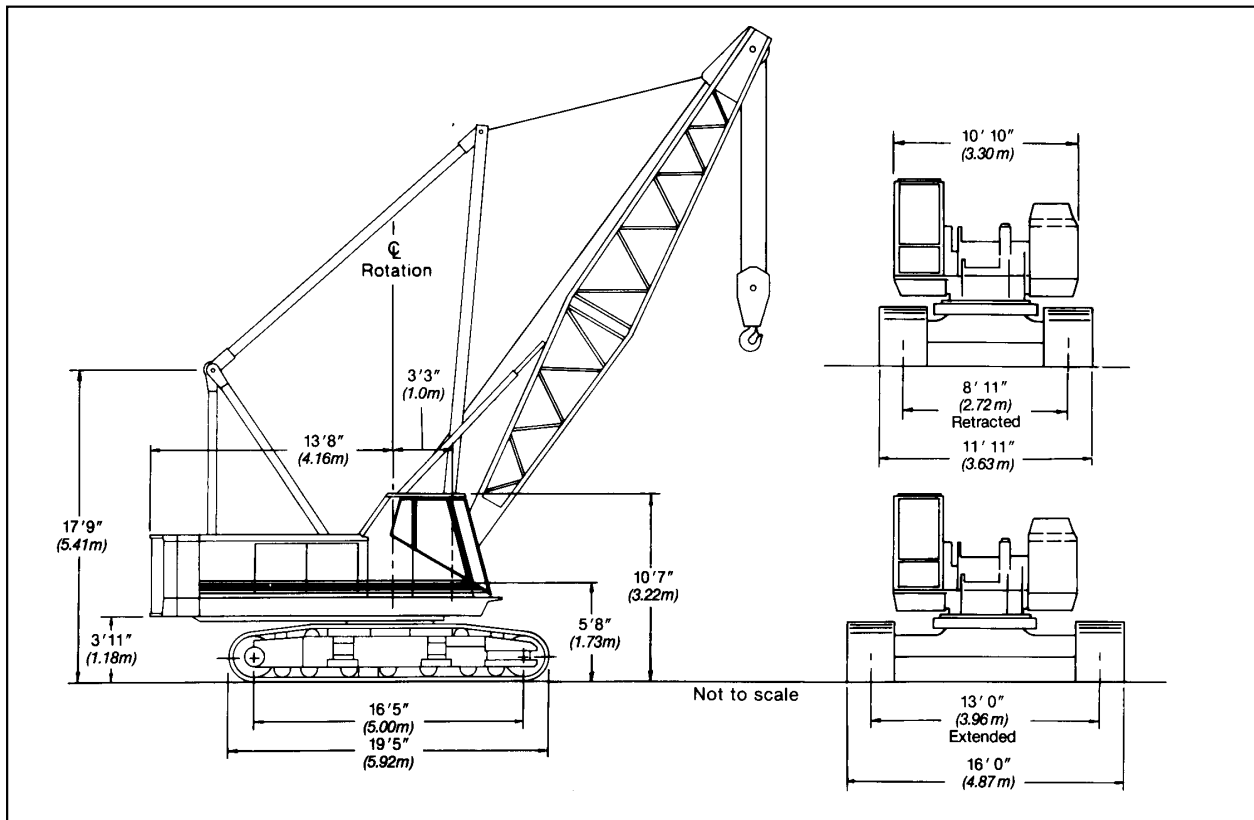

| General dimensions  | Feet    | meters |
|---|---------|--------|
| Basic boom length   | 40' 0"  | 12.20  |
| Overall width side frames extended<br>—36" (0.91 m) track shoes                   | 16' 0"  | 4.87   |
| Overall width side frames retracted<br>—36" (0.91 m) track shoes                  | 11' 11" | 3.63   |
| Overall width side frames removed<br>(axles in-line with truck – catwalks folded) | 10' 10" | 3.30   |
| Minimum ground clearance  | 16"     | 0.40   |

| General dimensions                           | Feet    | meters |
|--|---------|--------|
| Ground clearance – cwt. "A"                  | 3' 11"  | 1.19   |
| Ground clearance – cwt. "AB"                 | 3' 11"  | 1.19   |
| Overall width of counterweight               | 10' 2"  | 3.09   |
| Tailswing of counterweight "A"               | 13' 6"  | 4.10   |
| Tailswing of counterweight "AB"              | 13' 8"  | 4.16   |
| Overall width of upper (catwalks folded)     | 10' 10" | 3.30   |
| Overall height for transport, gantry lowered | 11' 2"  | 3.40   |



# Machine working weights – approximate

|  |              |
|--|--------------|
| Complete basic machine with Isuzu 6SA1T diesel engine, turntable bearing, hydraulic independent swing and travel, main operating drums and boomhoist, 40' (12.19 m) tubular boom w/live mast, no bucket or hook block but with 900' (274.3 m) of 7/8" (22.2 mm) dia. hoist rope. | Track shoes  |
|  | 36" (0.91 m) |
|  | pounds       |
| With 39,750 lb. (18 031 kg) counterweight "AB"   | 126,900      |

## Ground contact area

Note: Determining ground bearing pressure – divide the total weight of machine as shown above by the respective ground contact area.

| Track shoes |        | Ground contact areas |                 |
|-------------|--------|----------------------|-----------------|
| inches      | meters | in <sup>2</sup>      | cm <sup>2</sup> |
| 36          | 0.91   | 15,100               | 97,420          |

## Weight deductions for transporting – approximate

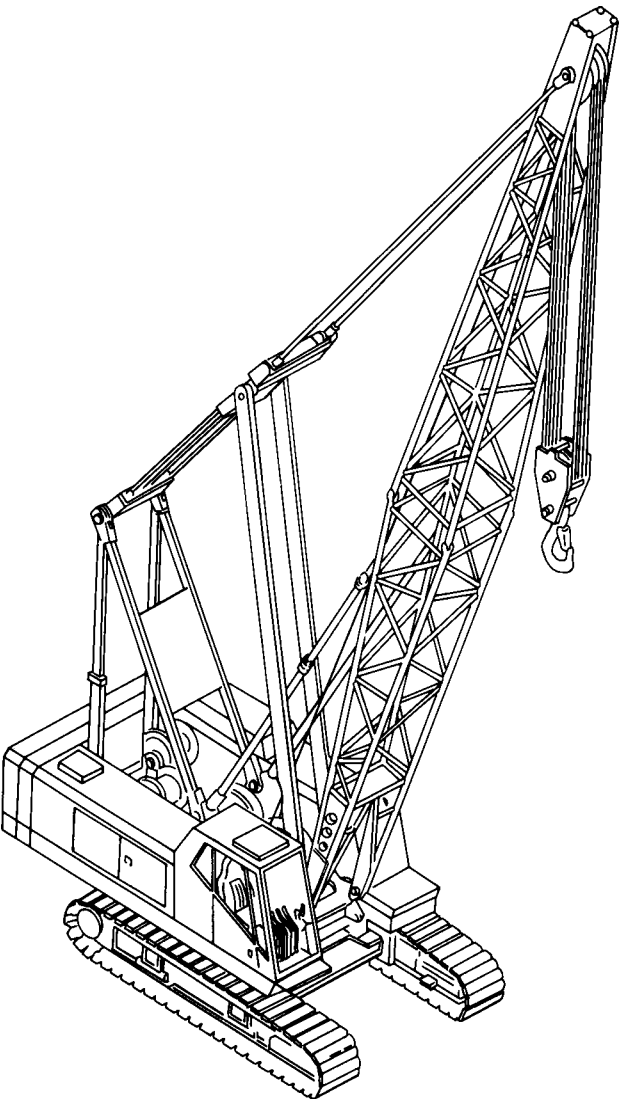

| Deduct or add for the following components:    | pounds | kilograms |
|--|--------|-----------|
| Counterweight "A"                              | 19,600 | 8 891     |
| Counterweight "AB"                             | 39,750 | 18 031    |
| <b>Basic 40' (12.19 m) tubular boom:</b>       |        |           |
| Tip: (includes head machinery)                 | 2,630  | 1 193     |
| Base   | 1,700  | 771       |
| Boom pendants - basic                          | 250    | 113       |
| Bridle and spreader bar                        | 765    | 347       |
| Boomhoist rope - 645' (196.6 m)                | 465    | 211       |
| Hoist rope - 900' (274 m) of 7/8" (22 mm) dia. | 1,280  | 581       |
| Live mast                                      | 1,550  | 703       |
| 10' (3.05 m) extension and pendants            | 650    | 295       |
| 20' (6.10 m) extension and pendants            | 1,055  | 479       |
| 30' (9.14 m) extension and pendants            | 1,450  | 658       |
| <b>Side frames:</b>                            |        |           |
| 36" (.91 m) track shoes                        | 36,220 | 16 429    |
| Lower carbody                                  | 10,890 | 4 940     |
| Catwalks                                       | 340    | 154       |
| Backstops                                      | 500    | 227       |
| Fairlead                                       | 500    | 227       |



# LS-138H Performance Specifications

## Wire rope and rope drum data

### Main load hoist wire rope length – using 7/8" (22 mm) diameter wire rope

| Parts of line | Boom lengths  |        |               |        |               |        |               |        |               |        |               |        |                |        |
|---------------|---------------|--------|---------------|--------|---------------|--------|---------------|--------|---------------|--------|---------------|--------|----------------|--------|
|               | 40' (12.19 m) |        | 50' (15.24 m) |        | 60' (18.29 m) |        | 70' (21.34 m) |        | 80' (24.38 m) |        | 90' (27.43 m) |        | 100' (30.48 m) |        |
|               | ft.           | meters | ft.           | meters | ft.           | meters | ft.           | meters | ft.           | meters | ft.           | meters | ft.            | meters |
| 1             | 105           | 32.00  | 125           | 38.10  | 145           | 44.20  | 165           | 50.29  | 185           | 56.39  | 205           | 62.48  | 225            | 68.58  |
| 2             | 150           | 45.72  | 180           | 54.86  | 210           | 64.01  | 240           | 73.15  | 270           | 82.30  | 300           | 91.44  | 330            | 100.58 |
| 3             | 195           | 59.44  | 235           | 71.63  | 275           | 83.82  | 315           | 96.01  | 355           | 108.20 | 395           | 120.40 | 435            | 132.59 |
| 4             | 240           | 73.15  | 290           | 88.39  | 340           | 103.63 | 390           | 118.87 | 440           | 134.11 | 490           | 149.35 | 540            | 164.59 |
| 5             | 285           | 86.87  | 345           | 105.16 | 405           | 123.44 | 465           | 141.73 | 525           | 160.02 | 585           | 178.31 | 645            | 196.60 |
| 6             | 330           | 100.58 | 400           | 121.92 | 470           | 143.26 | 540           | 164.59 | 610           | 185.93 | 680           | 207.26 | 750            | 228.60 |
| 7             | 375           | 114.30 | 455           | 138.68 | 535           | 163.07 | 615           | 187.45 | 695           | 211.84 | 775           | 236.22 | 855            | 260.60 |
| 8             | 420           | 128.02 | 510           | 155.45 | 600           | 182.88 | 690           | 210.03 | 780           | 237.74 | 870           | 265.18 | 960            | 292.61 |
| 9             | 465           | 141.73 | 565           | 172.21 | 665           | 202.69 | 765           | 233.17 | 865           | 263.65 | 965           | 294.13 |                |        |
| 10            | 510           | 155.45 | 620           | 188.98 | 730           | 222.50 | 840           | 256.03 | 950           | 289.56 |               |        |                |        |

| Parts of line | Boom lengths   |        |                |        |                |        |                |        |                |        |                |        |                |        |                |        |
|---------------|----------------|--------|----------------|--------|----------------|--------|----------------|--------|----------------|--------|----------------|--------|----------------|--------|----------------|--------|
|               | 110' (33.53 m) |        | 120' (38.58 m) |        | 130' (39.62 m) |        | 140' (42.67 m) |        | 150' (45.72 m) |        | 160' (48.77 m) |        | 170' (51.82 m) |        | 180' (54.86 m) |        |
|               | ft.            | meters | ft.            | meters | ft.            | meters | ft.            | meters | ft.            | meters | ft.            | meters | ft.            | meters | ft.            | meters |
| 1             | 245            | 74.68  | 265            | 80.77  | 285            | 86.87  | 305            | 92.96  | 325            | 99.06  | 345            | 105.16 | 365            | 111.25 | 385            | 117.35 |
| 2             | 360            | 109.73 | 390            | 118.87 | 420            | 128.02 | 450            | 137.16 | 480            | 146.30 | 510            | 155.45 | 540            | 164.59 | 570            | 173.74 |
| 3             | 475            | 144.78 | 515            | 156.97 | 555            | 169.16 | 595            | 181.36 | 635            | 193.55 | 675            | 205.74 | 715            | 217.93 | 755            | 230.51 |
| 4             | 590            | 179.83 | 640            | 195.07 | 690            | 210.31 | 740            | 225.55 | 790            | 247.79 | 840            | 256.03 | 890            | 271.27 | 940            | 286.51 |
| 5             | 705            | 214.88 | 765            | 233.17 | 825            | 251.46 | 885            | 269.75 | 945            | 288.04 |                |        |                |        |                |        |
| 6             | 820            | 249.94 | 890            | 271.27 |                |        |                |        |                |        |                |        |                |        |                |        |
| 7             | 935            | 284.99 |                |        |                |        |                |        |                |        |                |        |                |        |                |        |

### Dragline or clamshell wire rope lengths – using one part of line

| Attachments | Function | Boom Lengths  |        |               |        |               |        |               |        |
|-------------|----------|---------------|--------|---------------|--------|---------------|--------|---------------|--------|
|             |          | 40' (12.12 m) |        | 50' (15.24 m) |        | 60' (18.29 m) |        | 70' (21.34 m) |        |
|             |          | Feet          | meters | Feet          | meters | Feet          | meters | Feet          | meters |
| Clamshell   | Holding  | 110           | 33.53  | 130           | 39.62  | 150           | 45.72  | 170           | 51.82  |
|             | Closing  | 160           | 48.77  | 180           | 54.86  | 200           | 60.96  | 220           | 67.06  |
| Dragline    | Hoist    | 110           | 33.53  | 130           | 39.62  | 150           | 45.72  | 170           | 51.82  |
|             | Inhaul   | 65            | 19.81  | 75            | 22.86  | 85            | 25.90  | 95            | 28.96  |

### Drum wire rope capacities:

| Wire rope layer | Front or rear drum – 17-5/8" (0.45 m) root diameter grooved lagging, 7/8" (22 mm) wire rope |        |                 |        | Front mounted third drum – 12-3/4" (0.32 m) root diameter smooth lagging, 5/8" (16 mm) wire rope |        |                 |        | Boomhoist drum – 10-11/16" (0.27 m) root diameter grooved lagging, 5/8" (16 mm) wire rope |        |                 |        |
|-----------------|---|--------|-----------------|--------|--|--------|-----------------|--------|---|--------|-----------------|--------|
|                 | Rope per layer  |        | Total wire rope |        | Rope per layer   |        | Total wire rope |        | Rope per layer  |        | Total wire rope |        |
|                 | Feet  | meters | Feet            | meters | Feet   | meters | Feet            | meters | Feet  | meters | Feet            | meters |
| 1               | 101   | 31.0   | 101             | 31.0   | 77   | 23.5   | 77              | 23.5   | 46.0  | 14.0   | 46.0            | 14.0   |
| 2               | 109   | 33.5   | 211             | 64.5   | 84   | 25.6   | 161             | 49.0   | 50.5  | 15.4   | 96.5            | 29.4   |
| 3               | 118   | 36.1   | 330             | 100.6  | 91   | 27.7   | 252             | 76.8   | 54.8  | 16.7   | 151.3           | 46.1   |
| 4               | 126   | 38.6   | 456             | 139.2  | 99   | 30.1   | 351             | 107.0  | 59.4  | 18.1   | 210.7           | 64.2   |
| 5               | 134   | 41.1   | 591             | 180.3  | 106  | 32.3   | 457             | 139.3  | 63.6  | 19.4   | 274.3           | 83.0   |
| 6               | 143   | 43.6   | 734             | 223.9  |  |        |                 |        | 68.2  | 20.8   | 342.5           | 104.4  |
| 7               |   |        |                 |        |  |        |                 |        | 72.5  | 22.1   | 415.0           | 126.5  |
| 8               |   |        |                 |        |  |        |                 |        | 77.1  | 23.5   | 492.1           | 150.0  |
| 9               |   |        |                 |        |  |        |                 |        | 86.9  | 26.5   | 579.0           | 176.5  |



# LS-138H Load Hoisting Performance

Available line speed and line pull – based on ISUZU 6SA1T at 2100 rpm full load speed.

Line pulls are not based on wire rope strength. See wire rope chart for maximum permissible single part of line working loads.

## Front or Rear Drum: Line speeds and pulls

| 17-5/8" Root Dia. – 7/8" dia. rope |        |                   |       |      |       |                    |       |      |       |                   |       |      |       |
|------------------------------------|--------|-------------------|-------|------|-------|--------------------|-------|------|-------|-------------------|-------|------|-------|
| Single line pull                   |        | First layer speed |       |      |       | Fourth layer speed |       |      |       | Sixth layer speed |       |      |       |
|                                    |        | Low               |       | High |       | Low                |       | High |       | Low               |       | High |       |
| lbs                                | kgs    | fpm               | m/min | fpm  | m/min | fpm                | m/min | fpm  | m/min | fpm               | m/min | fpm  | m/min |
| 1,000                              | 454    | 138               | 42    | 276  | 84    | 177                | 54    | 354  | 108   | 203               | 62    | 406  | 124   |
| 5,000                              | 2 268  | 137               | 41    | 274  | 83    | 175                | 53    | 349  | 106   | 201               | 61    | 391  | 119   |
| 10,000                             | 4 536  | 136               | 41    | 244  | 74    | 174                | 53    | 284  | 86    | 198               | 60    | 304  | 92    |
| 15,000                             | 6 804  | 134               | 41    | 204  | 62    | 172                | 52    | 262  | 80    | 196               | 59    | 233  | 71    |
| 20,000                             | 9 072  | 133               | 40    | 170  | 51    | 170                | 51    | 179  | 54    | 174               | 53    | 174  | 53    |
| 22,700                             | 10 297 | 132               | 40    | 155  | 47    | 155                | 47    | 155  | 47    | -                 | -     | -    | -     |

## Wire rope: size, type and working strength

| Wire rope application     | Size: diameter |    | Type | Max. permissible load |        |
|---------------------------|----------------|----|------|-----------------------|--------|
|                           | inches         | mm |      | lbs.                  | kgs.   |
| Boom hoist                | 5/8            | 16 | W    | 11,700                | 5 307  |
| Main load hoist           | 7/8            | 22 | N    | 22,700                | 10 297 |
| Auxiliary hoist           | 7/8            | 22 | P    | 13,000                | 5 896  |
| Dragline inhaul           | 7/8            | 22 | M    | 22,700                | 10 297 |
| Dragline hoist            | 7/8            | 22 | N    | 22,700                | 10 297 |
| Clamshell Holding (hoist) | 7/8            | 22 | N    | 22,700                | 10 297 |
| Clamshell closing         | 7/8            | 22 | N    | 22,700                | 10 297 |
| Third drum                | 5/8            | 16 | N    | 11,700                | 5 307  |
| Boom pendants             | 1-1/4          | 32 | N    | 53,200                | 24 100 |

## Third drum: Line speeds and pulls

| Rope Layer | 12-3/4" Root Dia. |       |        |           |
|------------|-------------------|-------|--------|-----------|
|            | fpm               | m/min | pounds | kilograms |
| 1          | 210               | 64.0  | 9,200  | 4 173     |
| 2          | 230               | 70.1  | 8,400  | 3 810     |
| 3          | 250               | 76.2  | 7,800  | 3 538     |
| 4          | 269               | 82.0  | 7,200  | 3 266     |
| 5          | 289               | 88.1  | 6,700  | 3 039     |

## Wire rope: types available

- Type "M" – 6 X 25 (6 X 19 class), filler wire, extra improved plow steel, preformed, independent wire rope center, right lay, lang lay.
- Type "N" – 6 X 25 (6 X 19 class), filler wire, extra improved plow steel, preformed, independent wire rope center, right lay, regular lay.
- Type "W" – 6 X 26 (6 X 19 class), extra improved plow steel, preformed, independent wire rope center, right lay, alternate lay.
- Type "P" – 19 X 7 non-rotating, extra improved plow steel, preformed, wire strand core.



## Crawler Lower

### ■ Lower frame

All welded, box construction, precision machined; 13' extended, 8' 11" retracted gauge X 19'5" track length.

### ■ Turntable bearing

Outer race is bolted to upper frame, inner race with internal ring gear is bolted to lower frame.

### ■ Crawler side frames

All welded, precision machined and removable; hydraulically extended or retracted by a cylinder mounted inside the lower frame.

### ■ Track drive sprockets and idler wheels

Cast steel, heat treated; sealed for lifetime lubrication.

### ■ Track rollers

Ten per side. Tractor type, oil filled for lifetime lubrication.

### ■ Track carrier rollers

Three tractor type rollers mounted on top of each crawler side frame. Oil filled for lifetime lubrication.

### ■ Tracks

Heat treated, self cleaning, multiple hinged track shoes joined by one piece full floating pins; 50 shoes per side frame. Standard shoes 36" wide.

**Track tension adjustment** – Track adjusted by hydraulic cylinders at the idler block. Tracks automatically release during excessive tension condition.

### ■ Independent travel & Steering

Axial piston motor with reduction gear is located at inner drive end of each crawler side frame. Each track is driven simultaneously or individually for straight-line, gradual turn, or pivot turn. The tracks can be counter-rotated for spin turns.

**Brakes** – Spring applied, hydraulically released multiple disc brakes are applied automatically when the control lever is in the neutral position.

**Two speed travel** – high - 1.0 mph (1.7 km/h)  
– low - 0.6 mph (1 km/h)

Gradeability – 30%

## Revolving Upperstructure

### ■ Frame

All-welded, precision machined unit

### ■ Fuel tank

76 gallon (290 L) capacity

### ■ Power transmission

All functions hydraulically powered allowing positive, precise control, with independent or simultaneous operation of all crane functions.

| Engine Specifications   |                                 |
|---|---------------------------------|
| Isuzu 6SA1T with oil filter, oil cooler, air cleaner, fuel filter, water separator, hour meter, tachometer and electrical shutdown. |                                 |
| Number of cylinders   | 6                               |
| Bore and stroke – inch<br>– (mm)  | 4-17/32 X 5-5/16<br>(115 X 135) |
| Piston displacement<br>– (in³)<br>– (cm²)   | 513<br>(8413)                   |
| Engine rpm at full load speed<br>Hi-idle rpm  | 2100<br>2350                    |
| Net engine horsepower at full load speed, (HP)  | 195 (145 kw)                    |
| Peak torque – foot pounds<br>– (joule)  | 513<br>696                      |
| Peak torque – rpm   | 1400                            |
| Electrical system<br>Batteries  | 24 volt<br>2 - 12 volt          |



## Hydraulic System

### Hydraulic pumps

Two variable displacement piston pumps operating at 4000 PSI powers travel, main drum, auxiliary drum, third drum and boomhoist functions. One fixed displacement gear pump operating at 3000 PSI powers swing and crawler retract functions. One fixed displacement gear pump operating at 1210 PSI powers pilot control system, clutches, brakes and pump controls.

### Hydraulic reservoir

78 US gallon (295 L), equipped with sight level gauge.

### Relief valves

Each function is equipped with relief valves to protect the circuit from overload or shock.

### Brake valves

Travel circuit is provided with brake valves for all terrain travel capability.

### Hydraulic filtration

Ten micron, full flow line filter furnished in control circuit. All oil is filtered prior to return to sump tank.

### Hydraulic motors

Main, auxiliary and third hoist drums, boom hoist, swing and travel are powered by axial piston motors.

### Counterbalance valves

Hoist motors are equipped with counterbalance valves to provide positive load lowering and prevent accidental load drop when hydraulic power is suddenly reduced.

## Principal Operating Functions

### Control system

Remote controlled hydraulic servo for main drum, auxiliary drum, third drum and travel. Mechanical linkage controls swing. Function speed is proportional to lever movement. Levers are adjustable for operator comfort.

### Load hoisting and lowering

Main and auxiliary hoist drums are driven by individual axial piston motors and reduction gearing. Load hoisting or lowering is provided by actuating or reversing a hydraulic motor. Smooth, precise, power load lowering is attained with automatic hydraulic brake. The control lever provides two speeds for hoisting and lowering. Hoisting or lowering speeds are proportional to lever movement.

**Freefall** – The incorporation of power hydraulic controlled, two shoe clutches allows freefall operation of the main and auxiliary hoist drums for high cycle crane and duty cycle application. Mode selection switch on control panel allows operator to select the most productive operation mode.

### Load hoist drums

Main (front) and auxiliary (rear) hoist drums are 17-5/8" root diameter grooved for 7/8" (22.23 mm) wire rope and mounted on anti-friction bearings.

### Third operating drum

Pinned to front of main frame. Hydraulic winch type power up and down standard.

### Drum clutches

Speed-o-Matic® power hydraulic two-shoe clutches; internal expanding, lined shoes. Clutch spiders are splined to shafts; clutch drums are integral with hoist drums.

**Load hoist clutches** – Front and rear main drums – clutch drums 20" diameter, 5" face width. Swept area is 314 square inches.

### Drum brakes

External contracting band type; operated by foot pedal equipped with a locking latch. Operator may select automatic brake mode (spring applied, hydraulically released), which will apply brakes when the hoist control lever is in the neutral position.

### Drum rotation indicators

Standard for front and rear drums. Audible-type indicators.

### Drum locking pawl

Standard for front and rear drums; electrically actuated and prevents drum rotation in a lowering direction.

### Anti two-block system

Standard: A switch mounted on the boom peak activates a buzzer to warn the operator of a two-block condition and simultaneously disengages hoist function while applying the hoist brakes.



■ **Swing system**

Independent, hydraulic swing is driven by an axial piston motor through a gear reduction system.

**Swing brake** – Spring applied, hydraulically released; controlled by button on swing control lever.

**Swing lock** – Mechanically controlled, drop pin.

**Swing speed** – 0 to 2.8 r.p.m.

■ **Boomhoist / lowering system**

Independent, hydraulic boomhoist is driven by an axial piston motor through a gear reduction system. Boom hoisting or lowering is performed by actuating or reversing the motor.

■ **Boomhoist drum**

Single grooved lagging 10-11/16" root diameter.

■ **Boomhoist drum locking pawl**

Electrically operated.

■ **Boomhoist brake**

Spring applied, hydraulically released, multiple disc type brake. Brake is automatically applied when control lever is in neutral position.

Boomhoist limiting device – Restricts hoisting boom beyond recommended minimum radius.

■ **Electrical system**

24 volt negative ground system, with two 12-volt batteries. Standard lighting system includes: two 70 watt headlights mounted on machine front and one interior cab light.

■ **Operator's cab**

Full vision, modular compartment with safety glass panels. The completely independent cab is insulated against noise and vibration. Sliding operator's door, swing up roof window. Standard equipment includes: heater, defroster, windshield wiper, dry chemical fire extinguisher, sun visor, bubble-type level, fuel gauge, tachometer, hydraulic temperature gauge, engine oil pressure gauge, coolant temperature gauge and service monitor system.

■ **Machinery cab**

Hinged doors (two on right side, three on left side) for machinery access. Equipped with roof-top access ladder and electric warning horn.

■ **Catwalks**

Standard on both sides. Catwalks fold up for reduced travel width.

■ **Gantry**

Retractable high gantry is power lowered to reduce height for transport. May also be used for power raising or lowering of counterweight.

■ **Gantry bail**

Pinned to retractable high gantry. Six sheaves are provided for 14-part boomhoist wire rope reeving. Sheaves mounted on anti-friction bearings, sealed for lifetime lubrication.

■ **Counterweight**

Removable, held in position by bolts. Standard counterweight lowering system consists of retractable high gantry and hydraulic cylinders.

Counterweight "A" – 19,600 lbs. (8 891 kg)

Counterweight "AB" – 39,750 lbs. (18 031 kg)

## Booms and Jibs

■ **Booms**

**Angle** – Two piece basic boom 40' (12.19 m) long with open throat top section. Boom 48" (1.22 m) wide, 48" (1.22 m) deep at centerline of connections. Main chord angles are high strength, low alloy steel, 4" x 4" x 3/8" (101.6 mm x 101.6 mm x 9.53 mm).

**Boompoint machinery** – Four 18" (.46 m) root diameter head sheaves mounted on anti-friction bearings with rope and sheave guards standard for lift crane use. Three sheaves are standard for clamshell use. Dual 22" (.56 m) root diameter head sheaves with roller guards are standard for dragline use.

**Tubular** – Two piece basic boom 40' (12.19 m) long with open throat top section. Boom 54" (1.37 m) wide, 44" (1.12 m) deep at centerline of connections. Alloy steel, round tubular chords 3" (76 mm) outside diameter.

**Boompoint machinery** – Five 18" (.46 m) root diameter head sheaves mounted on anti-friction bearings with rope and sheave guards standard. For lift crane use.

**Items applicable to both booms:**

**Base section** – 20' (6.10 m) long. Boom feet 2-7/8" (73 mm) thick on 50" (1.27 m) centers. Lifting lugs on top side of base section to attach carrying links for boom assembly.

**Boom extensions** – Available in 10', 20' and 30' (3.05 m, 6.10 m, and 9.14 m) lengths with appropriate length pendants.

**Boom connections** – In-line tapered pins.

**Boom top section** – Open throat, 20' (6.10 m) long.



### ■ Angle jib

**Angle** – Basic two-piece 20' (6.10 m) long; 24" (.61 m) wide and 20" (.51 m) deep at connections. Alloy steel main chord angles, 2-1/2" x 2-1/2" x 5/16" (63 mm x 63 mm x 8 mm).

**Base section** – 10' (3.05 m) long.

**Jib extensions** – available in 10' (3.05 m) lengths with appropriate length pendants.

**Jib connections** – bolted.

**Jib tip section** – 10' (3.05 m) long, one 15-7/8" (.40 m) root diameter sheave mounted on anti-friction bearings.

### ■ Jib mast

10' (3.05 m) high, mounted on jib base section. One deflector sheave mounted on anti-friction bearings, mounted within mast to guide whipline. Two equalizer sheaves mounted on top of mast – one for jib frontstay line, one for jib backstay line.

**Jib staylines** – Front and rear staylines vary in length depending on degree of jib offset from boom centerline. Backstay lines attached at bottom end of boom top section.

**Jib mast stops** – Telescoping type.

### ■ Tubular jib

**Tubular** – Basic two-piece 20' (6.10 m) long, 30" (.76 m) wide and 24" (.61 m) deep at connections. Alloy steel tubular chords 1-1/2" (38 mm) outside diameter.

**Base section** – 10' (3.05 m) long.

**Jib extensions** – available in 10' (3.05 m) lengths with appropriate length pendants.

**Jib connections** – In-line, tapered pin connections.

## Link-Belt Construction Equipment Company

A unit of Sumitomo Construction Machinery Co., Ltd.

© Link-Belt is a registered trademark. Copyright 1995. All rights reserved. We are constantly improving our products and therefore reserve the right to change designs and specifications.

**Jib tip section** – 10' (3.05 m) long, one 15-1/4" (.39 m) root diameter sheave mounted on anti-friction bearings.

### ■ Jib mast

10' (3.05 m) high, mounted on jib base section. Two deflector sheaves mounted within mast to guide whipline; mounted on anti-friction bearings. Two equalizer sheaves mounted on top of mast – one for jib frontstay line, one for jib backstay line.

**Jib staylines** – Front and rear staylines vary in length depending on degree of jib offset from boom center line; backstay lines attached at bottom end of boom top section.

**Jib stops** – Telescoping type.

### ■ Boom stops

Dual, tubular telescopic type.

### ■ Boom live mast

24' (7.32 m) long rectangular structure which supports boomhoist bridle and boom pendants. Boom live mast may be used as a short crane boom for machine assembly or dismantling. Standard with tubular boom; optional for angle boom attachment.

### ■ Boomhoist bridle and spreader bar

Serves as connection for boom suspension system. Bridle contains seven 12" (.30 m) root diameter sheaves mounted on anti-friction bearings for 14-part boomhoist wire rope reeving. Auxiliary bail may be attached to bridle and contains two 15-7/8" (.40 m) root diameter bronze bushed sheaves to permit reeving wire rope suspension for use of boom live mast as short boom. Spreader bar provides attachment for boom main pendants.

### ■ Deflector rollers

Deflector roller and wear blocks deflect main and auxiliary load hoist wire rope over top side of boom. Roller is mounted on anti-friction bearings. One roller on top section and one wear block per extension is standard.

## Auxiliary Equipment

### ■ Boom angle indicator

Pendulum type, mounted on operator's side of boom base section.

### ■ Load indicator

*Optional;* electronic load indicator or rated capacity limiter for main or auxiliary hoist lines.

### ■ Fairlead

*Optional;* full revolving type with barrel, sheaves and guide rollers mounted on anti-friction bearings.

### ■ Tagline

*Optional;* Rud-o-Matic® model 1248; double barrel, spring wound, drum-type for angle boom.

*Optional;* Rud-o-Matic® model 648 for tubular boom.

### Bigge Crane and Rigging Co.

10700 Bigge Avenue  
San Leandro, CA 94577  
Phone: (888) 337-BIGGE or (510) 638-8100  
Fax: (510) 639-4053  
Email: info@bigge.com  
Web site: www.bigge.com