

General Specifications

Link-Belt® 200-ton (181.40 metric ton)

Wire rope truck crane

HC-258

GENERAL INFORMATION ONLY

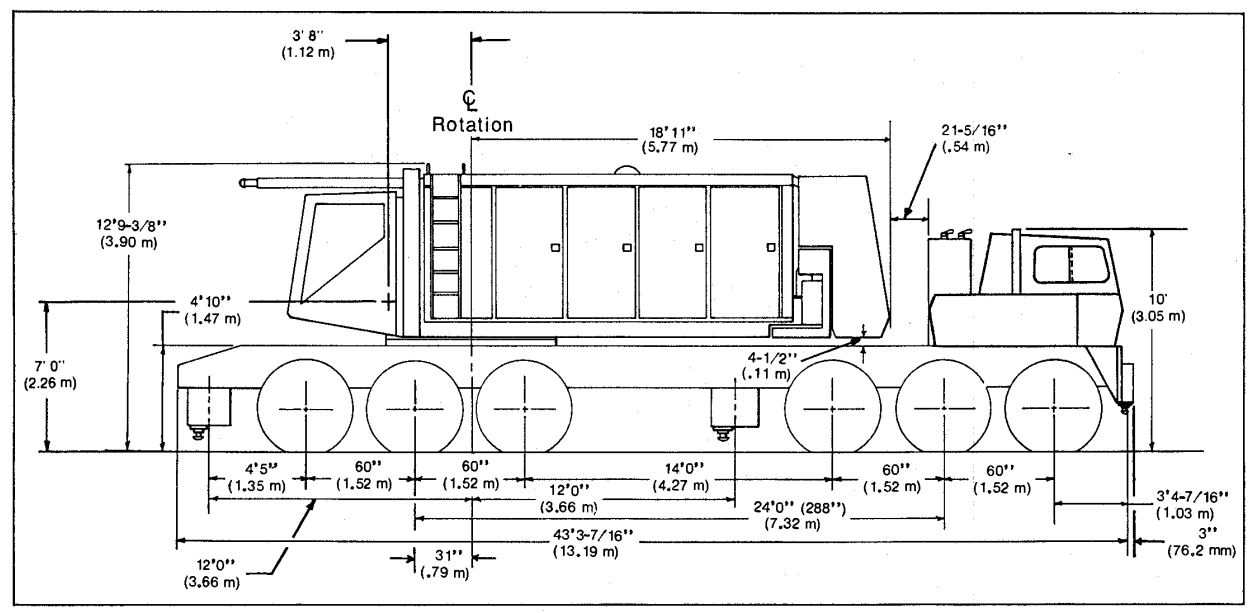

General Dimensions	Feet	Meters
Over-all width, outriggers extended (over floats)	26' 11"	8.20
Over-all width, outriggers extended (c/l of jacks)	24' 0"	7.32
Over-all width, outriggers retracted (jacks removed)	11' 10"	3.61
Vehicle clearance circle, over outside of front bumper	149' 2"	45.97
Vehicle clearance circle, over outside of front bumper ctwt.	150' 7"	45.90
Minimum ground clearance	1' 2"	.36
Ctwt. tailswing, across corners	19' 10"	6.05
Over-all width cab (upper)	11' 10"	3.61
Basic boom length — hammerhead	40' 4"	12.19
— tapered tip	120' 0"	36.58
Radius of boom hinge pin	3' 8"	1.12
Height of boom hinge pin	7' 0"	2.26
Over-all length; boom in travel position over rear of carrier, with "A" upper and "A" bumper ctwts. only —	—	—
40' (12.19 m) basic hammerhead boom	74' 2 ³ / ₈ " ①	22.62 ①
120' (36.58 m) basic tapered tip boom	155' 5 ⁵ / ₈ " ①	47.39 ①
Height, over boom live mast w/boom in travel position over rear of carrier —	—	—
40' (12.19 m) basic hammerhead boom	18' 8" ②	5.69 ②
120' (36.58 m) basic tapered tip boom	33' 2"	10.11
Ground clearance under ctwt.	5' 2 ¹ / ₂ "	1.59

① Interference with carrier cab prohibits over-the-road travel with either boom horizontal over front of carrier.
 ② Special boom carrying links (for hammerhead boom only) reduce over-all height to 12' 9" (3.89 m).



General Specifications

Carrier —

Type — FMC 288" (7.32 m) wheelbase, 12 x 6 drive, 11' 10" (3.61 m) wide.

Frame — Heat treated alloy steel; triple box construction. Machined mounting surface for outer race of turntable bearing with integral, external tooth swing (ring) gear.

Outriggers — Hydraulic beams and jacks; single outrigger at front center of carrier, dual outriggers mounted at center and rear of carrier.

Center and Rear — Outrigger box mounting pins hydraulically inserted/removed to facilitate strip down when outrigger box removal is required. Hydraulic outrigger beam and jack cylinders individually controlled — remotely operated outrigger control box (hand held) permits close-up examination of four outrigger beam/jack/float settings at their respective positions at midship and rear of carrier. Midship outrigger box equipped with rollers which ride in track to facilitate removal of outrigger assembly when required.

Front Center — Single hydraulic jack/float setting controlled by toggle switch at right front corner of carrier.

Floats — Low profile steel, 35" (.89 m) square.

Front Axles — Tridem; equalizer beam mounted, Shuler FTC AS34L-1, 114" (2.90 m) track.

Rear Axles — Tridem; Clark Planetary BD71000, equalizer beam mounted, 109 $\frac{7}{8}$ " (2.79 m) track.

Suspension — Hendrickson bronze bushed equalizer beams with fiber bushed torque rods.

Tires — Single tires on front axles, dual tires on rear axles.

Standard — 14:00 SR-1 x 24-L (20-ply rating), Custom Hi-Miler.

Optional — General HCT 14:00 x 24-N (24-ply rating).
— Goodyear SRL-1 14:00 x 24-L (20-ply rating).

Brakes — 12-wheel air brakes.

Service — Dual diaphragm air chambers on six rear wheels, single diaphragm on six front wheels.
— Size and Area. Rear wheels — 20" x 7" (.51 x .18 m); total lining area, 574 sq. in. (3,703.4 cm²) per axle. Front wheels — 17 $\frac{1}{4}$ " x 4" (.44 x .10 m); total lining area, 248 sq. in. (1,600 cm²) per axle.

Parking — Six rear wheel brakes applied with air control valve on carrier dash.

Emergency — Brakes on six rear wheels apply when air pressure drops below 40 p.s.i. (2.81 kg/cm²) in system. Emergency brake may be manually applied anytime by hand control of dash-mounted air control valve.

Steering — Power hydraulic. Ross model HPS70, 18" (.46 m) dia. wheel.

Carrier Engines — Diesel; with starter, full pressure lubrication, power steering pump, dry type air cleaner, 14.5 c.f.m. (.41 cu.m./min.) air compressor, and alternator.

Bumper Counterweight — "A" — 22,500# (10,206 kg). Mounts on front bumper frustums; easily removable. Note: Bumper ctwt. must not be used when "AB" upper ctwt. is used except when 260' (79.25 m) through 300' (91.44 m) boom lengths are used with jib. Bumper ctwt. must be used when only "A" upper ctwt. is used.

Vehicle Clearance Circle — Over outside of front bumper — 149' 2" (45.47 m); over outside of front bumper ctwt. — 150' 7" (45.90 m).

Specifications	General Motors 12V-71N	Cummins KT-450
Number of cylinders	12	6
Bore	4 $\frac{1}{4}$ " (.11 m)	6 $\frac{1}{4}$ " (.16 m)
Stroke	5" (.13 m)	6 $\frac{1}{4}$ " (.16 m)
Piston displacement	852 cu. in. (13,064 cm ³)	1,150 cu. in. (18,849 cm ³)
Max. brake h.p. @ r.p.m.	475 @ 2,100	450 @ 2,100
Governed load speed r.p.m.	2,100	2,100
Peak torque @ r.p.m.	1,200 ft. lbs. (152 kgm) @ 1,600	1,350 ft. lbs. (187 kgm) @ 1,500
Compression ratio	15.7 to 1	15.50 to 1
Electrical system	12-volt charging 24-volt starting	12-volt charging 24-volt starting
Batteries	Two 12-volt	Two 12-volt

Clutch — Lipe Rollway; 15 $\frac{1}{2}$ " (.39 m), 2 plate, dry disc.

Universal — Mechanics needle bearing.

Fuel Tanks — Two 45 gal. (170.33 liters) capacity tanks, filler pipe caps equipped with locking eye for padlock.

Electrical System — 12-volt negative ground system with series-parallel switch for 24-volt starting; includes dual sealed beam head lights, directional signals with 4-way flashing system, stop and tail lights, clearance lights, horn, dome light, dimmer switch, and two 12-volt 220 ampere hour batteries.

Cab — One-man, fully enclosed. Air suspension mounted bucket seat with seat belt. Sound absorbing head liner, carpet, and pleated upholstery. Instrument panel and dash include speedometer, odometer, voltmeter, and gauges for fuel, engine temperature, air and oil pressures. Low air pressure warning buzzer, key ignition switch, push button start, throttle control, tachometer, fire extinguisher, heater/defroster, and 2-speed electrical windshield wiper — standard.

Standard Auxiliary Equipment — Bus type rear view mirrors, boom guide, lug wrench, 2-way reading bubble levels on both sides of carrier, tire gauge and tire inflation hose. High pressure lube fittings at all bearing points, storage type running boards, hand grab rails, and skid-resistant finish on carrier deck.

GENERAL INFORMATION ONLY



Transmissions —

Main — Eaton RTO12515; fifteen speeds forward, three reverse.

Creep — Eaton AT1202; 2-speed, midship mounted.

Speeds —

Main - Eaton RTO 12515			Auxiliary - Eaton AT1202			
			1.00 : 1.00		2.036 : 1.00	
Gear		Ratio	m.p.h.	km/hr.	m.p.h.	km/hr.
High	10th	.79	43.1	69.3	21.2	34.1
	9th	1.00	34.0	54.7	16.7	26.9
	8th	1.30	26.2	42.2	12.9	20.8
	7th	1.66	20.5	33.0	10.1	16.3
	6th	2.16	15.8	25.4	7.7	12.4
	Rev.	2.16	15.8	25.4	7.7	12.4
Low	5th	2.79	12.2	19.6	6.0	9.7
	4th	3.55	9.6	15.4	4.7	7.6
	3rd	4.59	7.4	11.9	3.6	5.8
	2nd	5.90	5.8	9.3	2.8	4.5
	1st	7.65	4.4	7.1	2.2	3.5
	Rev.	7.65	4.4	7.1	2.2	3.5
Deep Reduction	5th	3.99	8.5	13.7	4.2	6.8
	4th	5.07	6.7	10.8	3.3	5.3
	3rd	6.56	5.2	8.4	2.5	4.0
	2nd	8.43	4.0	6.4	2.0	3.2
	1st	10.93	3.1	5.0	1.5	2.4
	Rev.	10.93	3.1	5.0	1.5	2.4

Creep speed in deep reduction low (1st) — based on peak engine torque of 1,600 r.p.m. — is 1.20 m.p.h. (1.93 km/hr.).
Note: Rear axle ratio — 9.0 to 1.0.

GENERAL INFORMATION ONLY

Axle Loadings — approximate

Based on std. HC-258 crane upper equipped with GM 8V-71N diesel engine w/twin torque converters, power load lowering clutches on front and rear main drums, and 21,000# (9,526 kg) "A" cwt.; mounted on FMC 288" (7.32 m) wheelbase, 12 x 6 drive carrier, 11' 10" (3.61 m) wide, equipped with 14:00 x 24-L (20-ply rating) tires; front center, center and rear power hydraulic outriggers, 22,500# (10,206 kg) "A" bumper cwt., and 5 outrigger floats in storage racks.

Component	Basic Machine Gross Weight		Upper Facing Front				Upper Facing Rear			
	Pounds	Kilograms	Front		Rear		Front		Rear	
			Pounds	Kilograms	Pounds	Kilograms	Pounds	Kilograms	Pounds	Kilograms
Upper Carrier	124,910	56,659	+65,120	+29,538	+ 59,790	+27,121	+ 65,120	+29,538	+ 59,790	+27,121
Total	220,350	99,951	+42,635	+19,339	+177,715	+80,612	+107,845	+48,918	+112,505	+51,033
Component Weights		Front		Rear		Front		Rear		
Pounds	Kilograms	Pounds	Kilograms	Pounds	Kilograms	Pounds	Kilograms	Pounds	Kilograms	
Upper Machinery —										
Counterweight "A"	-21,000	- 9,526	+12,240	+ 5,552	-33,240	-15,078	-16,470	- 7,471	- 4,530	- 2,055
Boom lowering clutch	+ 430	+ 195	- 100	- 45	+ 530	+ 240	+ 190	+ 86	+ 240	+ 109
Boomhoist wire rope (817' — 249.02 m, 7/8" — 22.23 mm, Type "N")	+ 1,160	+ 526	- 270	- 122	+ 1,430	+ 649	+ 520	+ 236	+ 640	+ 290
Rear drum planetary — load hoist	+ 680	+ 308	- 90	- 41	+ 770	+ 349	+ 240	+ 108	+ 440	+ 200
Rear drum planetary — load lowering	+ 680	+ 308	- 90	- 41	+ 770	+ 349	+ 240	+ 108	+ 440	+ 200
Rear drum wire rope (1,100' — 335.28 m, 1 1/8" — 28.58 m, Type "N")	+ 2,500	+ 1,134	- 330	- 150	+ 2,830	+ 1,284	+ 870	+ 395	+ 1,630	+ 739
Front drum planetary — load hoist	+ 680	+ 308	+ 30	+ 14	+ 650	+ 295	+ 120	+ 54	+ 560	+ 254
Front drum planetary — load lowering	+ 680	+ 308	+ 30	+ 14	+ 650	+ 295	+ 120	+ 54	+ 560	+ 254
Front drum wire rope (1,100' — 335.28 m, 1 1/8" — 28.58 m, Type "N")	+ 2,500	+ 1,134	+ 100	+ 45	+ 2,400	+ 1,089	+ 460	+ 209	+ 2,040	+ 925
Third drum without load lowering clutch	+ 2,580	+ 1,170	+ 370	+ 168	+ 2,210	+ 1,002	+ 180	+ 82	+ 2,400	+ 1,088
Third drum with load lowering clutch & gear	+ 3,300	+ 1,497	+ 480	+ 218	+ 2,820	+ 1,279	+ 240	+ 109	+ 3,060	+ 1,380
Third drum wire rope (817' — 249.02 m, 7/8" — 22.23 mm, Type "N")	+ 1,160	+ 526	+ 170	+ 77	+ 990	+ 449	+ 80	+ 36	+ 1,080	+ 490
Cummins NT-855 C 310 diesel engine	+ 450	+ 204	- 185	- 84	+ 635	+ 288	+ 280	+ 127	+ 170	+ 77
Quick disconnect turntable bearing	+ 1,440	+ 653	+ 155	+ 70	+ 1,285	+ 583	+ 155	+ 70	+ 1,285	+ 583
Carrier —										
Bumper counterweight "A"	-22,500	-10,206	-30,500	-13,836	+ 8,000	+ 3,629	-30,500	-13,836	+ 8,000	+ 3,629
Center outrigger box & beams	-10,150	- 4,604	- 6,150	- 2,790	- 4,000	- 1,814	- 6,150	- 2,790	- 4,000	- 1,814
Center jacks & cylinders (2 each)	- 2,540	- 1,152	- 1,540	- 699	- 1,000	- 454	- 1,540	- 699	- 1,000	- 454
Rear outrigger box & beams	-10,150	- 4,604	+ 4,050	+ 1,837	-14,200	- 6,441	+ 4,050	+ 1,837	-14,200	- 6,441
Rear jacks & cylinders (2 each)	- 2,540	- 1,152	+ 1,060	+ 481	- 3,600	- 1,633	+ 1,060	+ 481	- 3,600	- 1,633
Front center outrigger assembly including oil sump tank & jack	- 1,190	- 540	- 1,600	- 726	+ 410	+ 186	- 1,600	- 726	+ 410	+ 186
5 outrigger floats	- 900	- 408	- 220	- 100	- 680	- 308	- 220	- 100	- 680	- 308
Cummins KT450 diesel engine	+ 150	+ 68	+ 150	+ 68	0	0	+ 150	+ 68	0	0
Quick disconnect turntable bearing	+ 4,300	+ 1,950	+ 460	+ 209	+ 3,840	+ 1,741	+ 460	+ 209	+ 3,850	+ 1,741
Goodyear SRL-1 tires	+ 1,170	+ 531	+ 390	+ 177	+ 780	+ 354	+ 390	+ 177	+ 780	+ 354
General HCT Nygen tires	+ 1,386	+ 629	+ 462	+ 210	+ 924	+ 419	+ 462	+ 210	+ 924	+ 419
Attachment —										
25' (7.62 m) boom base section w/4 connecting pins — horizontal over rear	+ 2,790	+ 1,266					- 1,670	- 758	+ 4,460	+ 2,023
40' (12.19 m) basic hammerhead boom w/o hook block — horizontal over rear	+ 7,390	+ 3,352					- 9,130	- 4,141	+16,520	+ 7,493
Boom stops, supports & levers	+ 1,320	+ 599	+ 10	+ 5	+ 1,310	+ 594	+ 280	+ 127	+ 1,040	+ 471
35' (10.67 m) boom live mast, bridle & spreader bar — mast horizontal	+ 6,360	+ 2,885	+ 7,570	+ 3,434	- 1,210	- 549	- 6,200	- 281	+12,560	+ 5,697
Boomhoist rope reeving to horizontal boom live mast	+ 1,160	+ 526	+ 820	+ 372	+ 340	+ 154	- 570	- 259	+ 1,730	+ 785



Weight Breakdown For Transporting — (Approximate)

Combined Weight — Live Mast, Boom Stops and Boomhoist Rope — 8,950# (4,060 kg)

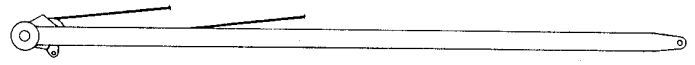

Boom Live Mast with Boomhoist Rope



Boom Stops

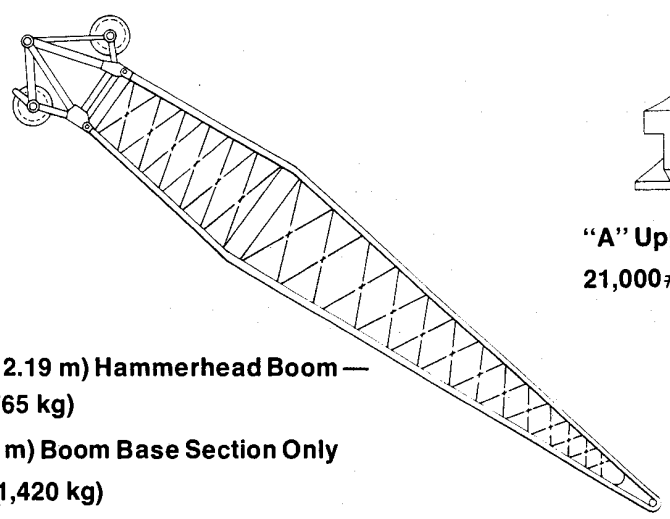

Basic 40' (12.19 m) Hammerhead Boom —
8,300# (3,765 kg)

25' (7.62 m) Boom Base Section Only
3,130# (1,420 kg)

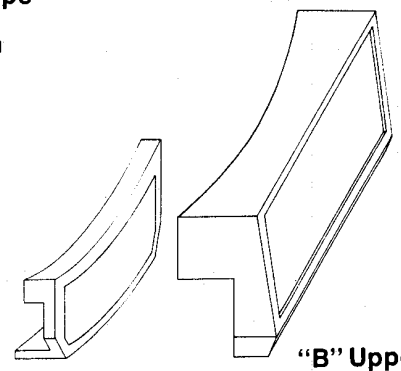

"A" Upper Cwt. —
21,000# (9,526 kg)

"B" Upper Cwt. —
49,000# (22,226 kg)

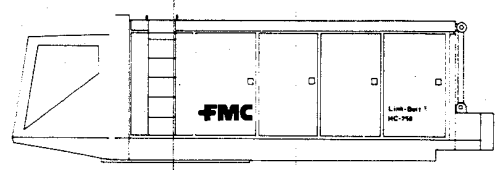

Upper — 75,650# (34,315 kg)

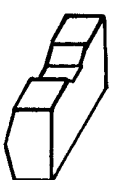

Bumper Cwt. —
22,500# (10,206 kg)

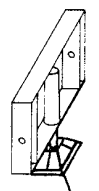

Front Center Outrigger Assembly
990# (449 kg) w/o Floats
1,170# (530 kg) w/Floats

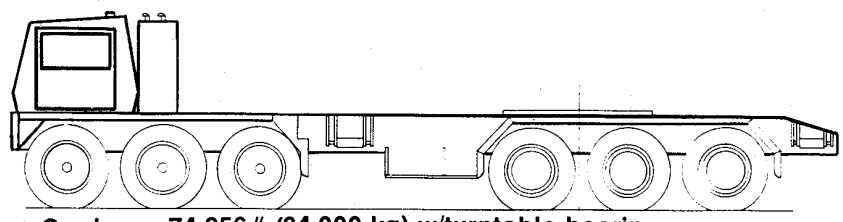

Carrier — 74,956# (34,000 kg) w/turntable bearing

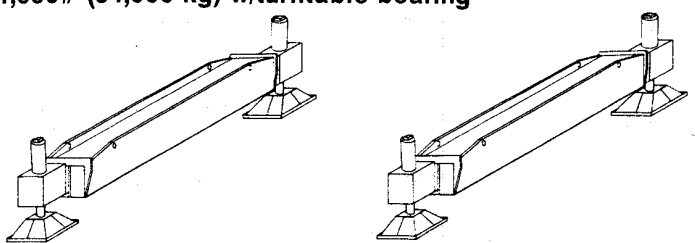

Each Front and Rear Outrigger
Box with Beams, Jacks and Cylinders —
12,690# (5,756 kg) w/o Pontoons
13,082# (5,934 kg) w/Pontoons

GENERAL INFORMATION ONLY



Revolving Upperstructure —

Frame — All-welded, stress relieved, precision machined; machinery side housings integral with frame.

Turntable Bearing — Inner race mounted on machined surface on upper frame; outer race, with integral external tooth swing (ring) gear, mounted on carrier. Optional patented hydraulic cylinder actuated quick disconnect lock ring facilitates removing upper from carrier for transporting.

Upper Machinery — Expanded Full-Function design. Machine-cut teeth on drum gears, pinions, spur gears, sprockets and chain wheels. Components such as gears, pinions, sprockets, chain wheels, wire rope drums, brake drums and clutch spiders — involute splined on shafts. Operating shafts mounted on anti-friction bearings; drum gear/clutch drum assemblies bolted together and mounted on shafts on anti-friction bearings.

Transmissions — Roller chain for main load hoist and swing systems; quadruple width chain for load hoist, triple width chain for swing. Chain drives transfer power from engine/torque converter (2) power packages to expanded Full-Function gear train.

Engines — Diesel, with full pressure lubrication, oil filter, air cleaner, hour meter, hand and foot throttles.

Specifications	General Motors 8V-71	Cummins NT855-C310
Number of cylinders	8	6
Bore	4¼" (.11 m)	5½" (.14 m)
Stroke	5" (.13 m)	6" (.15 m)
Piston displacement	568 cu. in. (9,310 cm ³)	855 cu. in. (14,013 cm ³)
Max. brake h.p. @ full load load speed r.p.m.	277 @ 2,000	305 @ 2,000
High idle speed	2,190 r.p.m.	2,200 r.p.m.
Peak torque @ converter stall	3,067 ft. lbs. (424 kgm)	3,139 ft. lbs. (434 kgm)
Electrical system	12-volt	12-volt
Batteries	Two 12-volt	Two 12-volt
Clutch or power take-off	Disconnect clutch between engine and converter gear box	Disconnect clutch between engine and converter gear box
Transmission — Number chain wheel teeth Number engine pinion teeth	93 ① 18 ①	93 ① 18 ①

① Applicable to either main hoist or swing transmissions.

Fuel Tank — 145 gal. (548.8 liters) capacity; equipped with fuel level gauge and flame arrester filler pipe cap with locking eye for padlock.

Principal Function Systems —

Swing, load hoisting/lowering and boom hoisting/lowering systems independent of one another.

Swing System —

Swing gear train powered through chain drive by independent Type 4 torque converter. Converter equipped with modulating hydraulic wet disc clutch — provides operator infinite control of available torque for smooth, precise swing. Single bevel gear on horizontal and vertical swing shafts; swing pinion meshes with external teeth of swing (ring) gear.

Swing Clutches — 23" (.58 m) dia. x 6" (.15 m) face width; aluminum alloy shoes.

Swing Brake — External contracting band; spring applied, hydraulically released; 21" (.53 m) dia. x 3¾" (.98.43 m) face width.

Swing Lock — Operator controlled pawl; hydraulically engaged and released. Pawl engages external teeth of turntable bearing swing (ring) gear.

Maximum Swing Speed — 2.4 r.p.m.

Load Hoisting/Lowering System —

Wire rope drum gear train (front and rear main, and optional third, operating drums) powered through chain drive by independent Type 4 torque converter. Independent torque converter assures ample torque for load line speeds and pulls (as well as for boom hoisting/lowering) without affecting swing system.

Front and Rear Drums — One-piece, smooth; 19¼" (.55 m) root diameter. Ratchet wheel for drum locking pawl cast integral with drum flange.

Third Drum — Optional. One-piece, smooth; 17¼" (.44 m) root diameter. Ratchet wheel for drum locking pawl cast integral with drum flange.

Drum Clutches — Control load hoist and power load lowering. Clutches for front and rear main operating drums — 30" (.76 m) dia. x 6½" (.17 m) face width. Clutches for optional third drum — 23" (.58 m) dia. x 6" (.15 m) face width. Gray, cast iron shoes in front and rear drum clutches, aluminum alloy shoes in third drum clutches.

Power Load Lowering Clutches — Standard on front and rear main operating drums; optional on optional third drum.

Drum Locking Pawls — Operator controlled; spring applied, hydraulically released. Standard on front, rear and optional third drums.

Drum Rotation Indicators — Standard for front and rear main operating drums. Two solenoid operated indicator buttons, recessed in drum clutch control lever handles; one button pulsates when rope drums rotate in one direction, the other button pulsates when drums rotate in opposite direction. Three to five pulsations represent approximately 1" (25.40 mm) rope travel on or off drum.

Drum Planetary Drive Units — Optional for load hoist and/or load lowering on either or both front and rear main operating drums. Available for either increased or decreased load line speeds — choice predetermined by customer at time of machine order. Planetary drive units controlled by external contracting band brakes through push button located on hoist/lowering clutch control lever handles. Standard line speeds controlled by Speed-o-Matic power hydraulic 2-shoe clutches. When machine is equipped with optional low speed planetary drive unit for power load lowering, standard 2-shoe power hydraulic load lowering clutch then provides a second speed control (higher than planetary) for load lowering.

GENERAL INFORMATION ONLY

Available Maximum Line Pull — (representative) developed by machinery at standard wire rope drum speed, GM 8V-71N diesel engine, and 1½" (28.58 mm) dia. wire rope, but **not** based on wire rope strength —

Front Drum — 35,000# (15,876 kg) line pull @ 165 ft/min (50.29 m/min) line speed.

Rear Drum — 37,500# (17,010 kg) line pull @ 163 ft/min (49.68 m/min) line speed.

Permissible Line Pull and Speed — (representative) based on 1½" (28.58 mm) dia. wire rope strength —

Front Drum — 35,000# (15,876 kg) line pull @ 165 ft/min (50.29 m/min) line speed.

Rear Drum — 37,100# (16,828 kg) line pull @ 163 ft/min (49.68 m/min) line speed.

Boom Hoist/ Lowering System —

Independent, spur gear driven. Precision control — hoisting through power hydraulic 2-shoe clutch, lowering through low speed planetary drive unit.

Boom Hoist Clutch — 23" (.58 m) dia. x 6" (.15 m) face width; aluminum alloy shoes.

Boom Lowering Clutch — Optional; 23" (.58 m) dia. x 6" (.15 m) face width. Available, in addition to planetary drive unit, for higher boom lowering speed when desired.

Boom Hoist/Lowering Brake — External contracting band; spring applied, hydraulically released. Brake drum splined on shaft at right of boomhoist wire rope drum. Brake 34" (.86 m) dia. x 5½" (.14 m) face width.

Wire Rope Drum — One-piece, smooth; 17¼" (.44 m) root diameter. Ratchet wheel for drum locking pawl cast integral with drum flange.

Drum Locking Pawl — Operator controlled; spring applied, hydraulically released.

Boomhoist Limiting Device — Provided to restrict hoisting boom above recommended minimum radius; located on exterior right-hand side of operator's cab. Electrical switch, contacted by boom in near vertical position, actuates hydraulic solenoid valve which shuts off hydraulic pressure in line to boom hoist clutch. As pressure is shut off, boom hoist brake is spring applied.

Gantry — Mounted to upper frame; supports boom suspension system.

Bail — Pinned to gantry; supports boom suspension system. Bail contains 8 sheaves for 18-part boomhoist rope reeving; sheaves mounted on anti-friction bearings.

Control System —

Speed-o-Matic® power hydraulics; a variable pressure system. Operating pressure is transmitted through oil to all operating cylinders. The system includes a pump to provide a constant flow of oil, an accumulator to maintain operating pressure, oil filter, relief valve, unloader valve, and variable pressure operator controlled valves to regulate the pressure to each hydraulic cylinder. Oil sump tank — FMC, 12 gal. (45.42 liters) capacity with filter and strainer assembly.

Clutches — Speed-o-Matic® power hydraulic actuated, 2-shoe type, for all clutch actuated functions except engine master clutch.

Operator's Cab — Environmental cab, modular type with sliding door; isolated from upper machinery cab. Entire cab hydraulically raises as much as 4' (1.22 m) in height for improved operator view on specialized jobs. Cab door and windows equipped with tinted safety glass panels. Standard cab equipment includes hand grab rail, cab heater/defroster and windshield wiper.

Upper Machinery Cab — Equipped with warning horn, hinged doors for access to machinery, roof-top access ladder and skid-resistant finish on roof.

Counterweight — Total 70,000# (31,752 kg). "A" cwt. — 21,000# (9,526 kg) — held in place on two hydraulically controlled frustums; frustum control valves located at rear of upper machinery cab. "B" cwt. — 49,000# (22,226 kg) — bolted in position on top and to rear of "A" cwt. "A" or "AB" ctwts. lowered to, or raised from, carrier deck in seconds. ("B" cwt. alone cannot be lowered).

Attachment —

Boom — Tubular; three section basic boom with **hammerhead top section** — 40' (12.19 m) long.

Base Section — 25' (7.62 m) long; 80" (2.03 m) wide, 68" (1.73 m) deep.

Straight Extensions — Available in 10' (3.05 m), 20' (6.10 m), 30' (9.14 m), 40' (12.19 m) and 50' (15.24 m) lengths; 80" (2.03 m) wide, 68" (1.73 m) deep, centerline-to-centerline of main chords. In making up various boom lengths, straight extensions *must be arranged* in the boom as outlined on boom make-up plate #28P673.

Tapered Extensions — 10' (3.05 m) long; 80" (2.03 m) wide, 68" (1.73 m) deep at lower end and 55" (1.40 m) wide, 41" (1.04 m) deep at top end — for use on boom lengths 40' (12.19 m) through 100' (30.48 m). 50' (15.24 m) long tapered extension (same box section dimensions as 10') required for use on boom lengths 110' (33.53 m) through 290' (88.39 m).

Note: Tapered extensions must always be used as last boom section prior to mounting hammerhead top section.

Hammerhead Top Section — 5' (1.52 m) long; 55" (1.40 m) wide, 41" (1.04 m) deep at lower end.

—**Maximum hammerhead boom length permitted** . . . 280' (85.34 m) with "A" upper and "A" bumper ctwts; 290' (88.39 m) with "AB" upper cwt. and no bumper cwt.

Boompoint Machinery — Six 21" (.53 m) root diameter sheaves; mounted on anti-friction bearings.

Boom Stops — Lever; tubular type.

Boom — Tubular; three section basic boom with **tapered tip top section** — 120' (36.58 m) long.

Base Section — 25' (7.62 m) long; 80" (2.03 m) wide, 68" (1.73 m) deep.

Straight Extensions — Available in 10' (3.05 m), 20' (6.10 m), 30' (9.14 m), 40' (12.19 m) and 50' (15.24 m) lengths; 80" (2.03 m) wide, 68" (1.73 m) deep, centerline-to-centerline of main chords. In making up various boom lengths, straight extensions *must be arranged* in the boom as outlined on boom make-up plate #28P674.

Tapered Extension — 50' (15.24 m) long; 80" (2.03 m) wide, 68" (1.73 m) deep at lower end and 55" (1.40 m) wide, 41" (1.04 m) deep at top end.

Note: Tapered extension must always be used as last boom section prior to mounting tapered tip top section.

Tapered Tip Top Section — 45' (13.72 m) long; 55" (1.40 m) wide, 41" (1.04 m) deep at lower end.

—**Maximum tapered tip boom length permitted** . . . 290' (88.39 m) with "A" upper and "A" bumper ctwts.; 310' (94.99 m) with "AB" upper cwt. and no bumper cwt.

Boompoint Machinery — Three 28½" (.73 m) root diameter sheaves; mounted on anti-friction bearings.

Boom Stops — Lever; tubular type.

GENERAL INFORMATION ONLY



Items Applicable to Both Hammer-head and Tapered Tip Booms —

GENERAL INFORMATION ONLY

Boomfeet — 4" (101.60 mm) wide on 66" (1.68 m) centers; 5" (.13 m) diameter boomfoot pins. Pins hydraulically removed/inserted for ease in strippdown. Double-acting hydraulic cylinder mounts on frame between boomfoot lugs. Boomfoot pins — one connected to cylinder rod end, the other connected to the cylinder body — are pushed in, or pulled from, connection with boomfeet.

Boom Connections — In-line pin connections.

Boomhoist Bridle & Spreader Bar — Serves as connection between boom pendants and boomhoist wire rope reeving. Bridle contains nine 15" (.38 m) root diameter sheaves for 18-part boomhoist rope reeving; sheaves mounted on anti-friction bearings.

Boom Live Mast — Mounts on front of upper frame; supports boomhoist bridle, spreader bar, and boom midpoint suspension pendants. Mast 35' (10.67 m) long; may be used as short boom for handling counterweight, outrigger assemblies, etc. in machine strippdown and boom assembly.

— Maximum lifting capacity of mast is 70,000# (31,752 kg) from 12' (3.66 m) minimum to 33' (10.06 m) maximum radius with machine on outriggers (midship and rear) with either "A" or "AB" upper ctwts. Load hoist rope required — minimum 3 parts of 1 1/8" (28.58 mm) dia., Type "N" wire rope, off rear main operating drum only.

Boom Live Mast Stops — Incorporated with boom stops; manually positioned when live mast is used as short boom.

Boom Midpoint Suspension Pendants — Standard; required for all boom lengths exceeding 230' (70.10 m).

Boom Angle Indicator — Mechanical pendulum type; mounted on boom base section.

Load Hoist Rope Deflector Rollers — Furnished to minimize hoist rope chafing against top side of boom; rollers mounted on anti-friction bearings.

Standard — One roller on each 10' (3.05 m), 20' (6.10 m), and 30' (9.14 m) extension; two on each 40' (12.19 m) and 50' (15.24 m) extension.

Jib — Tubular; two-piece basic jib 30' (9.14 m) long; base and top sections each 15' (4.57 m) long, pin connected. Jib 32" (.81 m) wide, 24" (.61 m) deep at connections. Maximum jib length permitted — 70' (21.35 m). All jib lengths may be mounted at 5°, 15°, or 25° offset to boom.

Jib Extensions — Available in 20' (6.10 m) lengths; pin connections.

Jib Peak Sheave — Supports jib load hoist rope (whipline); mounted on anti-friction bearings.

Jib Mast — 17' 10" (5.43 m) high; mounted on jib base section. Two deflector sheaves within the mast, mounted on anti-friction bearings, to guide jib load hoist rope (whipline). Equalizer sheaves provided for jib frontstay and backstay ropes. Backstay ropes fastened at lower end of boom top section.

Jib Stops — Telescoping type; pinned from jib mast to boom top section and from jib mast to jib base section.

Wire Rope —

Type "N" — 6 x 25 (6 x 19 class), filler wire, extra improved plow steel, preformed, independent wire rope center, right lay, regular lay.

Type "P" — 19 x 7 non-rotating, extra improved plow steel, preformed, wire center core.

Wire Rope Application	Type and Size Used
Boomhoist	7/8" (22.23 mm) dia., Type "N"
Main Load Hoist	1 1/8" (28.6 mm) dia., Type "N"
Jib Load Hoist (1-part)	1" (25.4 mm) dia., Type "P"
Jib Load Hoist (2-part)	1" (25.4 mm) dia., Type "N"
Boom Pendants	1 1/2" (38.1 mm) dia., Type "N"
Boom Midpoint Suspension Pendants	7/8" (22.23 mm) dia., Type "N"
Jib Frontstay Line	7/8" (22.23 mm) dia., Type "N"
Jib Backstay Line	7/8" (22.23 mm) dia., Type "N"

Bigge Crane and Rigging Co.

10700 Bigge Avenue
 San Leandro, CA 94577
 Phone: (888) 337-BIGGE or (510) 638-8100
 Fax: (510) 639-4053
 Email: info@bigge.com
 Web site: www.bigge.com

We are constantly improving our products and therefore reserve the right to change designs and specifications.

