

**JMG Cranes S.p.A.**

Sales & Service Office  
Via Bergamo, 142  
26100 Cremona - Italy  
t +39 0372 1786738  
Production Plant  
Via Sito Nuovo 14  
29010 Sarmato (PC) - Italy  
t +39 0523 8486  
e info@jmgcranes.com



[www.jmgcranes.com](http://www.jmgcranes.com)

Data subject to change without prior notice  
Edition 03/2020 © 2020 JMG Cranes S.p.A. All rights reserved  
Rev.1 - 03/20



Electric  
Pick & Carry  
Cranes

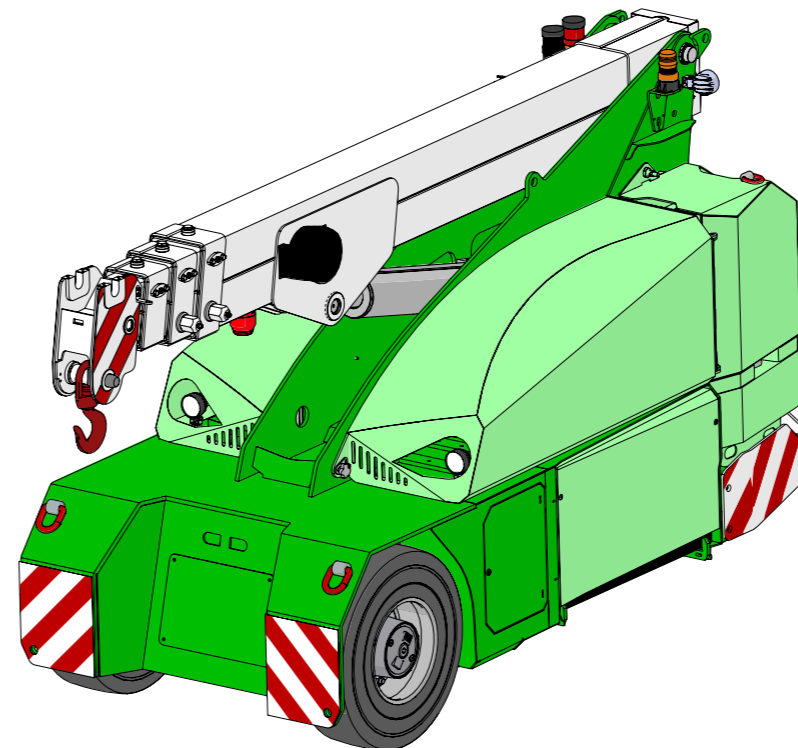

**MC 60S (inch)**  
Max Capacity 13,200 lbs

**JMG**<sup>®</sup>  
movetosolution

# MC 60S

RADIO-REMOTE CONTROL ON DRIVING, STEERING, BOOM MOVEMENTS, WINCH AND OTHER ACCESSORIES

FRONT-WHEELS DRIVE WITH COUNTER ROTATION

REMOVABLE COUNTERWEIGHTS

HYDRAULICALLY TELESCOPING SEQUENTIAL TYPE BOOM

**Options :**

- HYDRAULIC WINCH
- HYDRAULIC FLY JIB
- BENDABLE MANUAL JIB WITH MANUAL EXTENSION
- NON-MARKING TIRES
- HYDRAULIC FORKS
- MAN BUCKET
- ATEX CONVERSIONS
- CUSTOMIZED PAINTING



## Technical features

Max Capacity lbs	13,200
Dimensions inch	10'6"x3'9"x6'4"

Front-wheels drive. 2 electric motors AC 3,5 kW 72V Insulation class H	<b>LMI.</b> Electronic safe load indicator and tilting moment limiter
Total lbs 15,000 Removable counterweights lbs 4,100	Automatic braking system on all wheels
72 V - 640 Ah 8 working hours	Fabricated from preformed and welded quality steel plate
Front nr. 2 superelastic 250-15" Rear nr. 2 superelastic 21x8-9"	+60°/-15°
Rear Steering angle -90°/+90°	Motor driven pump 12 kW - 72 V AC, Insulation class H



## Load charts

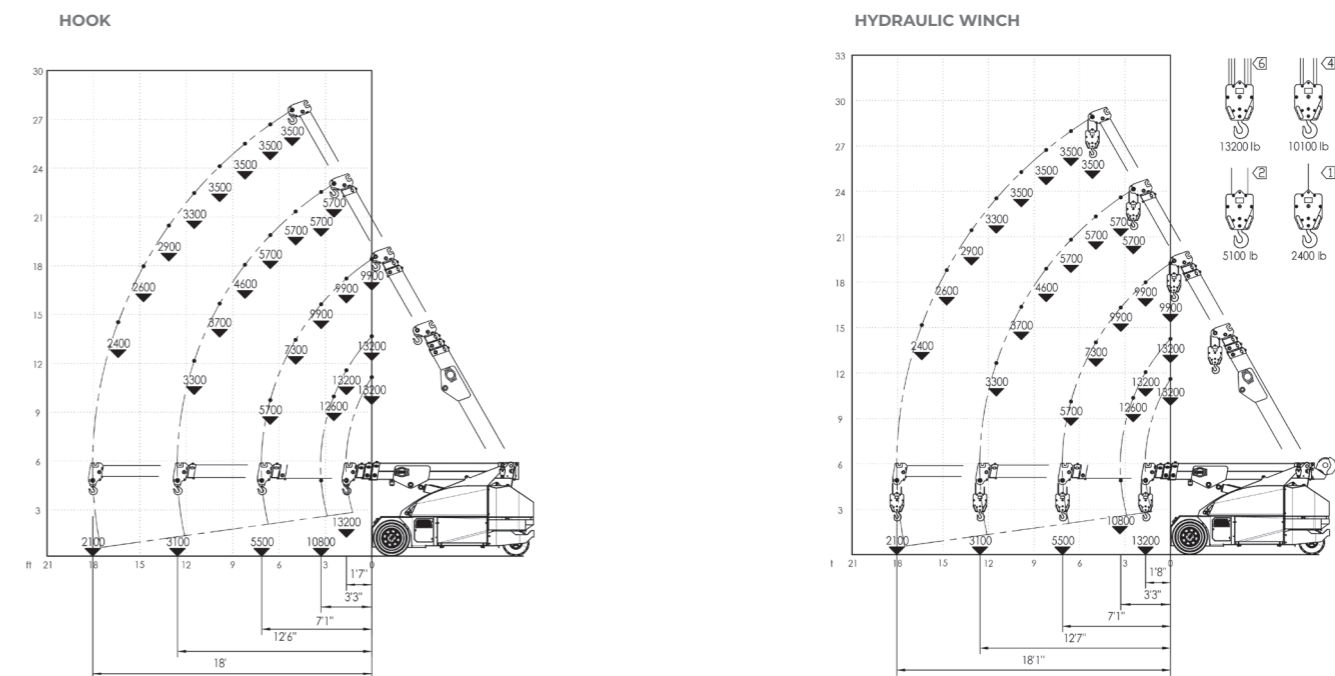

## EU Standards CE

	UNI ISO 4030-1: A1
	2006/42/CE- 2000/14/CE -2014/30 UE 2014/35/UE - D.Lgs 262/2002 subsequent modifications
	EN 13000:2014 subsequent modifications



## Dimensions

