



CRANE CAPACITY CHART IC-200-2F

CAPACITIES APPLY TO OPERATION ON FIRM LEVEL SURFACE							
LOAD RADIUS FEET	MAIN BOOM OR EXTENSION CAPACITIES IN POUNDS						
	360° ROTATION		OVER FRONT				
	ON RUBBER	ON OUTRIGGERS	ON RUBBER	ON OUTRIGGERS	ON OUTRIGGERS		
MAIN BOOM	6	16200	30000	17000	30000		
	8	13200	24000	13800	24000		
	10	11000	19800	11500	19800		
	12	8100	16100	9600	16100		
	14	6250	13500	7900	13500		
	16	5000	11200	6300	11200		
	18	4100	10000	5100	10000		
	20	3400	8800	4300	8800		
	22	2850	7700	3600	7800		
	24	2400	6600	3000	6900		
	26	2100	5750	2600	6200		
	28	1850	5150	2300	5700		
	30	1650	4650	2100	5300		
	32	1450	4200	1850	4900		
	36	1150	3400	1500	4200		
	15' BOOM EXT.	40	900	3050	1200	3600	
		44	650	2600	950	3100	
		48	450	2200	750	2700	
51		250	1900	600	2400		
15-FOOT BOOM EXTENSION - STRAIGHT OR OFFSET							
MAIN BOOM ANGLE							
BOOM EXTENSION ANGLE	0°	15°	30°	40°	50°	60°	70°
0°	--	3100	3450	3900	4650	6000	7500
15°	--	3000	3100	3300	3650	4250	5200
30°	--	--	3000	3050	3200	3450	3900

CAUTION BOOM EXTENSION LOADS MUST NOT EXCEED MAIN BOOM CAPACITY.

BOOM EXTENSION DEDUCT: 400 LBS. WHEN STOWED ON BASE BOOM;
800 LBS. IN WORK POSITION WITH LOAD ON MAIN BOOM.

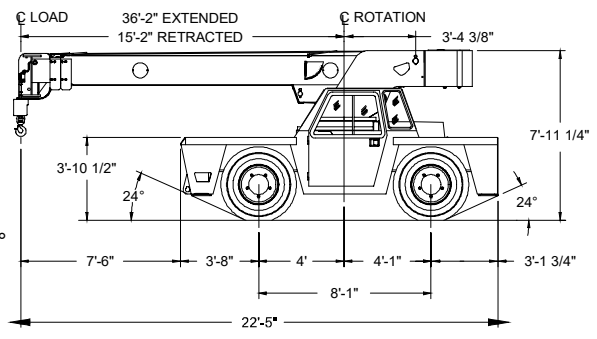
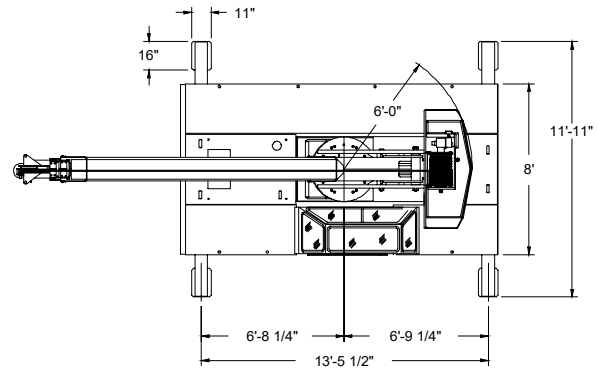
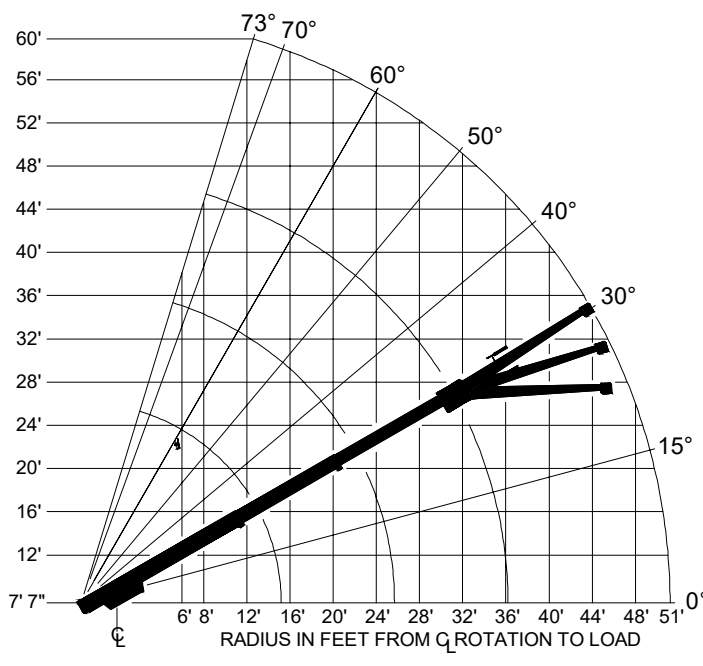
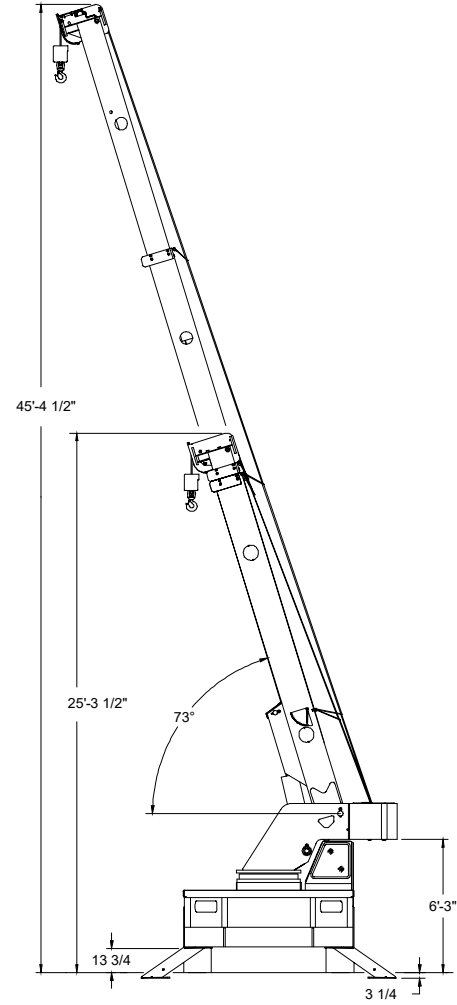
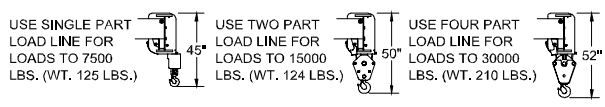



CRANE CAPACITY CHART IC-200-3F

LOAD RADIUS FEET	CAPACITIES IN POUNDS FOR OPERATION ON FIRM LEVEL SURFACE							
	MAIN BOOM ONLY				BOOM EXTENSION			
	ON RUBBER		ON OUTRIGGERS		ON RUBBER		ON OUTRIGGERS	
6	16000	16400	30000	30000	---	---	---	---
8	12500	13000	22400	22400	---	---	---	---
10	10000	10500	18500	18500	7500	7500	7500	7500
12	8040	8700	15700	15700	7500	7500	7500	7500
14	6500	7200	13500	13500	7500	7500	7500	7500
16	5330	6200	10800	10800	6140	7500	7500	7500
18	4450	5400	9560	9560	5010	6440	7500	7500
20	3720	4700	8550	8550	4200	5430	7500	7500
22	3140	4200	7700	7700	3580	4650	6850	6850
24	2680	3700	6980	6980	3080	4030	6250	6250
26	2300	3200	6300	6350	2660	3530	5750	5750
28	1980	2800	5550	5800	2290	3100	5300	5300
30	1700	2460	4830	5320	1990	2710	4920	4920
32	1470	2150	4200	4900	1730	2400	4580	4580
34	1260	1850	3700	4520	1510	2130	4270	4270
38	920	1300	2970	3870	1140	1680	3530	3760
42	640	950	2400	3340	840	1320	2960	3340
46	390	650	1840	2890	600	1040	2440	2980
50	0	550	1750	2520	410	800	2040	2630
54	---	---	---	---	0	600	1710	2290
58	---	---	---	---	0	430	1370	2000
62	---	---	---	---	0	290	1140	1740
66	---	---	---	---	0	0	930	1500

BOOM EXT. ANGLE	BOOM EXTENSION - STRAIGHT OR OFFSET							
	MAIN BOOM ANGLE							
	0°	15°	30°	40°	50°	60°	70°	
0°	3000	3100	3450	3900	4650	6000	7500	
15°	---	3000	3000	3000	3000	3700	5000	
30°	---	---	2500	2500	2600	3100	3800	

CAUTION BOOM EXTENSION LOADS MUST NOT EXCEED CAPACITIES IN ANGLE CHART AND LOAD RADIUS CHART.

BOOM EXTENSION DEDUCT: 400 LBS. WHEN STOWED ON BASE BOOM;
800 LBS. IN WORK POSITION WITH LOAD ON MAIN BOOM.

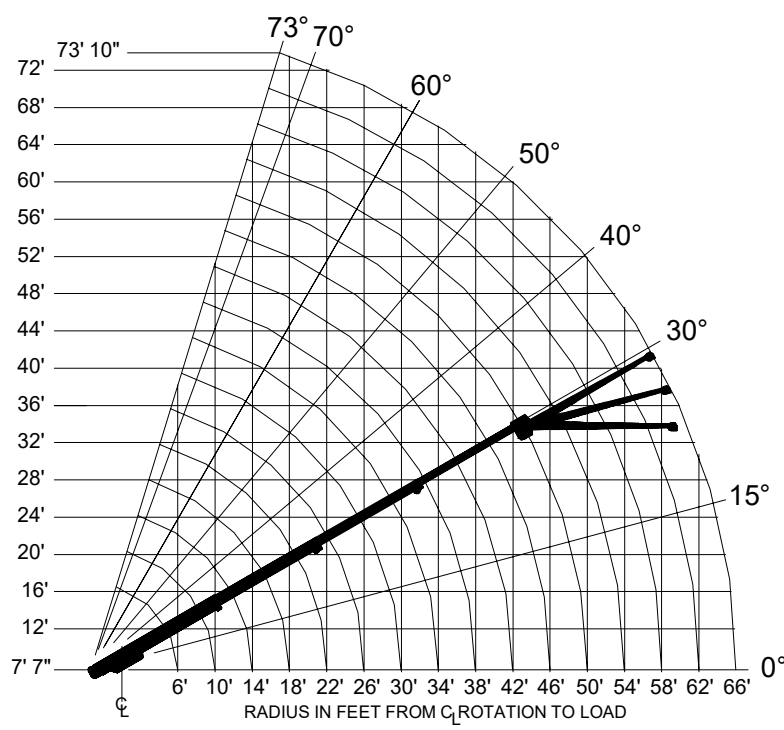
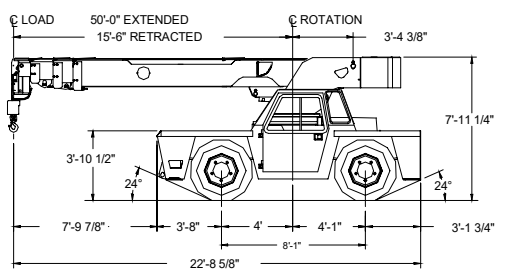
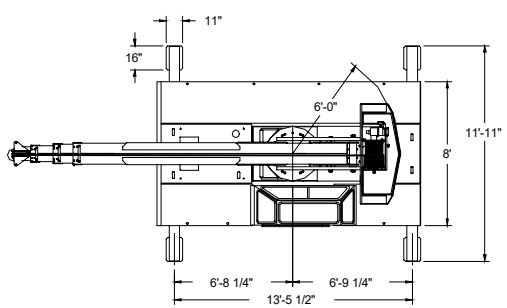
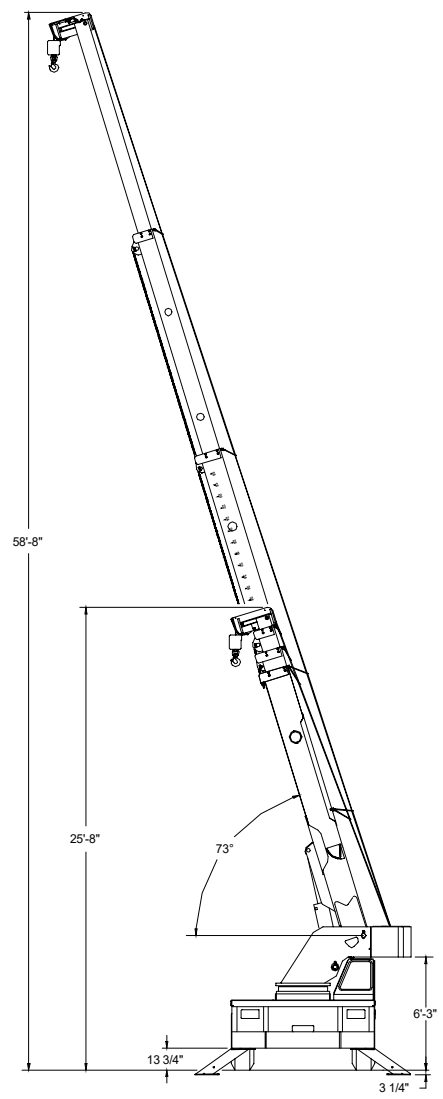
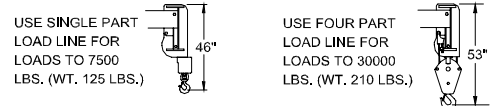

**GENERAL:**

Weight:	IC-200-1F	IC-200-2F	IC-200-3F
	27,300 lbs.	27,750 lbs.	30,150 lbs.
Boom Movement:			
Rotation	Continuous	Continuous	Continuous
Elevation	0° to 73°	0° to 73°	0° to 73°
Extension	15' 4"	21' 0"	34' 6"
Boom Speeds:			
Rotation	1.8 RPM	1.8 RPM	1.8 RPM
Elevation	21 sec.	21 sec.	21 sec.
Extension	26 sec.	35 sec.	53 sec.
Gradeability:	75% (37 Degrees)		
Turning Radius:	13' 9"		

ENGINE:	Standard	Optional
Make	GM	Cummins
Model	4.3L V-6	4BT3.9
Type	Gasoline	Turbo-Diesel
No. Cyl.	6	4
Displacement	262 CID	239 CID
HP @ Gov. Speed	110 H.P.	110 H.P.
Fuel Tank Capacity	30 Gallons	

TRANSMISSION:

Powershift transmission with 4-speeds forward and reverse. Provides powershifts at any engine speed in any gear. All shifting is done with a single lever electrical control mounted on the steering column. Equipped with torque convertor and transmission oil cooler. Torque convertor has stall ratio of 2.2:1.

Gear Ratio:

First	5.72:1	Second	3.23:1
Third	1.77:1	Fourth	1.00:1

AXLES:

Front Axle:
Planetary drive/steer front axle with 15.78 to 1.0 ratio. Differential equipped with "limited slip" feature. Front axle mounted rigidly to frame.

<u>Gear</u>	<u>Travel Speed</u>	<u>Drawbar Pull*</u>
First	3 MPH	19,000*
Second	6 MPH	10,000*
Third	11 MPH	5,700*
Fourth	20 MPH	3,000*

*Drawbar pull is calculated for GM 4.3L engine.

Rear Axle:

Standard (2-Wheel Drive):

Steering axle with 1-1/2 degree oscillation in either direction.

Optional (4-Wheel Drive):

Planetary drive/steer axle with 24.98 to 1.0 ratio. Differential is not "limited slip" in rear axle. 1-1/2 degree oscillation in either direction. Axle ratio compatible with 4-wheel drive transmission output for front axle match. Transmission equipped with electro-hydraulic control for shifting between 2-wheel drive and 4-wheel drive.

STEERING:

Full hydraulic steering unit with two 3-inch cylinders attached to each axle. Allows limited steering when engine is not running. A switch on the control panel is used to select rear-wheel steering, four-wheel steering or crab steering. Electronic sensors and control box automatically align the steering when a new mode is selected.

BRAKES:

- Service:** Split-system, 4-wheel hydraulic-boosted multiple-plate wet disc brakes.
- Parking:** Hand lever actuated disc-type parking brake on transmission.

TIRES: 15x22.5, 16-ply rating.

OPERATOR COMPARTMENT:

Provides one-position access to all chassis and crane functions. Includes adjustable operator's seat, retracting seat belts, fire extinguisher and bubble level.

CHASSIS:**Cargo Deck:**

72 square feet of deck area. 17,000 lbs. capacity on deck when load is centered over or between axles. Steps located on front corners.

Lifting Rings

Lifting rings at each corner of load deck so sling can be attached for lifting crane.

Outriggers:

Four hydraulic outriggers of box beam construction with direct-connected holding valves. Independent controls for each outrigger. Outrigger pad dimension: 11" x 16".

Accessory Storage Box:

Storage box is 14" deep x 10-1/2" long x 36-1/2" wide, located in front cargo deck.

ELECTRICAL:**12 Volt System****Lighting Package:**

One pair headlights with high and low beams, tail, brake and turn signal lights and back-up lights in rear, front turn signals and emergency flasher switch at operator's station.

Instrument Package:

Fuel, ammeter, oil pressure, water temperature and transmission oil temperature gauges. All gauges are lighted. Hourmeter records hours only during actual engine operation. Also included are warning lights for low transmission pressure, turn signals, high beams, hazard lights, park brake and four-wheel drive.

Back-Up Alarm:

Provides pulsating sound when transmission is in reverse.

Outrigger Alarm System:

Two-tone alarm is activated when "outrigger down" controls are operated.

HYDRAULIC SYSTEM:

Tandem pump, direct-driven by engine crankshaft, rated at 29 and 34 GPM at rated RPM. Hydraulic oil tank capacity of 54 gallons.

BOOM ASSEMBLY:

Three or four section boom assembly equipped with bearing pads, double-acting hydraulic cylinders with direct-connected holding valves and boom angle indicator on each side of boom.

Boom Rotation:

Heavy-duty ball bearing rotation gear with external teeth. Rotation is powered by hydraulic motor and worm gear drive.

Boom Hoist:

Turret mounted planetary gear hoist hydraulically powered with a bare drum line pull of 10,000 lbs. at a line speed of 100 FPM. Includes downhaul weight, swivel hook and sheave block for 4-part line and 240 ft. of 1/2" hoist rope.

Anti-Two-Block Device:

Prevents damage to hoist rope and/or crane components from pulling load hook against tip.

Sheave Block, Four Part Line

Double sheave block for 4-part line requirements.

Rated Capacity Limiter

Warns operator of impending overload with audible and visual signals. Prevents overloads by stopping boom functions that cause overloads.



Listed below are brief descriptions of each option available for the IC-200-F Industrial Crane. Consult the IC-200-F Engineering Spec for additional information on each option.

MODEL:

- IC-200-1F** Industrial Crane with 12' 8"-28' 0" Boom
- IC-200-2F** Industrial Crane with 15' 2"-36' 2" Boom
- IC-200-3F** Industrial Crane with 15' 6"-50' 0" Boom

ENGINE OPTIONS:

- Diesel Engine**
Cummins Turbo-4BT3.9
- Spark Arrester Muffler**
Installed in addition to std. muffler.
- Catalytic Converter**
Reduces engine emissions.
- Engine Heater**
Engine coolant heater installed to circulate warm water through engine, plugs into 120 volt AC.
- Ether Injection System**
Ether starting aid controlled by switch in operator compartment and injects ether directly into intake manifold.
- Engine Shut Down Gauges**
Shuts engine off when high water temperature or low engine oil pressure occurs. (Diesel Only)

Axle & Steering Options:

- 4-Wheel Steer & 2-Wheel Drive**
- 4-Wheel Steer & 4-Wheel Drive**

TIRE OPTIONS:

- Non-Marking Tires**
- Foam Filling of Tires**
- Spare Tire & Wheel**

CHASSIS OPTIONS:

- Auxiliary Winch**
Mounted behind front bumper, hydraulically driven with control in operator's console.
- Pintle Hook:**
 - Pintle Hook, Rear**
 - Pintle Hook, Front**
- Headlight and Taillight Grilles**
Welded steel protective grilles for headlights and taillights.
- Rearview Mirrors**
One mounted on right-hand deck stake and one mounted on left-hand deck stake.

OPERATOR COMPARTMENT OPTIONS:

- Operator Guard**
Tubular steel weldment with heavy expanded steel mesh top section.
- Operator Guard Cover**
Clear vinyl cover over Operator Guard, for inclement weather operations.
- Operator Guard Door**
Hinged door covers operator compartment side opening.
- All Weather Cab**
Rigid-mounted canopy section and removable hinged door. Includes heater, electric windshield wiper, one sliding glass window in the door & one in the right side of canopy. Defroster fan & dome light included.
- Cab Heater Only**
Heater with two-speed fan for units without All Weather Cab.

- Windshield Washer**
Includes reservoir, pump and nozzle.

- Floor Mat**
Vinyl mat with foam backing.

- Operator Suspension Seat**
Provides additional operator comfort.

- Noise Reduction Kit**
Includes floor mat, control valve cover and side panels of foam backed vinyl for noise reduction.

- Air Conditioning**
Air Conditioner with R 134 coolant.

ELECTRICAL OPTIONS:

- Strobe Lights**
Yellow strobe light mounted on each side of turret weight box.
- Amber Rotating Beacons**
Amber rotating beacon mounted on each side of turret weight box.
- Boom Work Lights**
One work light mounted to boom to light boom tip and one work light mounted to turret to light ground under boom tip.

BOOM ATTACHMENTS:

- Boom Extension, 15 Ft.**
Boom stowable.
- Boom Extension, 15 Ft., Offsettable (2F Only)**
Same as above except the boom extension is offsettable to 3 different positions; 0 degree (inline), 15 degree and 30 degree offset.
- Boom Extension, 16 Ft., Offsettable (3F Only)**
Same as above except the boom extension is 16 ft.
- Sheave Block - Two-Part Line**
- Searcher Hook:**
 - Nose Mount**

Should you, as an end user, require an option or special equipment on your IC-200-F that is not listed on our sales literature, please contact your dealer salesperson or the factory to receive a special quoted price.